

NOAA Data Report ERL AOML-20

SHIPBOARD ACOUSTIC DOPPLER CURRENT PROFILER DATA  
COLLECTED DURING THE  
SUBTROPICAL ATLANTIC CLIMATE STUDIES (STACS) PROJECT (1983-1986)

Anne Marie Wilburn  
Doug Wilson

Atlantic Oceanographic and Meteorological Laboratory  
Miami, Florida  
March 1991



**UNITED STATES  
DEPARTMENT OF COMMERCE**

**C. William Verity  
Secretary**

**NATIONAL OCEANIC AND  
ATMOSPHERIC ADMINISTRATION**

William E. Evans  
Under Secretary for Oceans  
and Atmosphere/Administrator

Environmental Research  
Laboratories

Vernon E. Derr,  
Director

## NOTICE

Mention of a commercial company or product does not constitute an endorsement by NOAA Environmental Research Laboratories. Use for publicity or advertising purposes of information from this publication concerning proprietary products or the tests of such products is not authorized.

## CONTENTS

	<u>Page</u>
1. INTRODUCTION.....	1
2. DESCRIPTION: AMETEK-STRAZA ACOUSTIC DOPPLER CURRENT PROFILER 4400....	1
3. NAVIGATION.....	3
A. SATNAV.....	5
B. LORAN-C.....	5
4. CALIBRATION.....	6
5. DATA PROCESSING.....	6
6. REFERENCES.....	9
7. ACKNOWLEDGMENTS.....	10
APPENDIX A: ADCP U-V VELOCITY PLOTS.....	11

SHIPBOARD ACOUSTIC DOPPLER CURRENT PROFILER DATA COLLECTED DURING THE  
SUBTROPICAL ATLANTIC CLIMATE STUDIES (STACS) PROJECT (1983-1986)

Anne Marie Wilburn  
Doug Wilson

1. INTRODUCTION

The Subtropical Atlantic Climate Studies (STACS) Program of NOAA is directed at determining the role of ocean circulation in global atmospheric climate, providing data for numerical model verification and establishing monitoring strategies for climatically important circulation features. The initial emphasis of STACS was on the subtropics, in general, where earlier studies suggested that oceanic heat flux in the Atlantic is a maximum and the Florida Current, in particular, a major component in the net oceanic heat flux at about the latitude of Miami (Molinari, 1989). Results of a two-year study have provided data on the Florida Current which enabled us to better understand the role of the Florida Current in circulation and oceanic heat flux. The study also provided a system for monitoring this current on a long-term basis. Shipboard data from this study can be found in Williams *et al.* (1983), Leaman and Vertes (1983), Vertes and Leaman (1984), and Ratnaswamy *et al.* (1985).

From 1984-1986 STACS efforts were concentrated on the Florida Current and its relationship to circulation in the Caribbean Sea and the area of the Antillean Archipelago. Data from cruises during this period are presented in Wilburn *et al.* (1987a,b). STACS was further extended southward down to 4°N latitude in 1987 in an effort to determine the contribution of cross-equatorial boundary currents to heat flux in the North Atlantic (consult Wilburn *et al.*, 1988 for data from these cruises).

Several of these STACS cruises were undertaken aboard the NOAA Ship MALCOLM BALDRIGE (formerly NOAA Ship RESEARCHER). In September of 1982 an acoustic Doppler current profiler (ADCP) manufactured by the Ametek-Straza Company of California was mounted aboard the BALDRIGE. This report presents the ADCP data obtained during STACS cruises from December 1983 through September 1987. Table 1 presents a list of the cruises covered in this report.

2. DESCRIPTION: AMETEK-STRAZA ACOUSTIC DOPPLER CURRENT PROFILER 4400

The ADCP installed on the NOAA Ship MALCOLM BALDRIGE measures vertical profiles of oceanic currents down to a depth of about 200 m. The system consists of: (1) a power amplifier which transmits the outgoing pulse; (2) a hull-mounted, three-beam transducer which transmits and receives a 115 kHz acoustic pulse through the water column; and (3) a signal processor to measure the Doppler shift of the return signal (see Figure 1).

The transducer has an overall diameter of 46 cm and contains three acoustic radiators which transmit five-degree wide acoustic beams in a Janus configuration. This configuration simplifies data processing and reduces the effects of ship, roll, pitch and heave. Each beam is inclined 30 degrees from the vertical with one beam pointing forward along the hull of the ship and the other two beams separated in azimuth by 120 degrees. All of the radiators are driven by a common power amplifier and produce a sound pressure level of 210 dB/Pascal at the face of the radiator.

Table 1

Cruises from which ADCP data were obtained

Cruise	Cruise Dates
December 1983	22 November-15 December
March 1984	14 March-23 March
August 1984	27 August-6 September
April 1985	17 April-17 May
August 1985	13 August-6 September
January 1986	13 January-11 February
March 1986	25 March-22 April
July 1986	15 July-8 August
October 1986	23 October-7 November (Leg I) 10-21 November (Leg II)
March 1987	11-23 March (Leg I) 23-30 March (Leg II)
September 1987	1-14 September (Leg I) 16 September-1 October (Leg II)

The motion of the water relative to the ship can be calculated by analyzing the Doppler shift frequency of the backscattered returns. The Doppler shift of each of the 63 range (depth) bins is determined by the ADCP's signal processor.

The profiler is linked via an IEEE-488 General Purpose Interface Bus (GPIB) to a shipboard data acquisition system which uses navigation data acquired from LORAN-C and SATNAV (TRANSIT SATNAV) to determine ship speed over ground which is then used to calculate current velocity. Figure 2 shows a diagram of the shipboard data acquisition system linked with the Ametek-Straza profiler. The system is described in detail in Bitterman and Wilson (1983).

The data acquisition system aboard the MALCOLM BALDRIGE has as its central processing unit (CPU) a DEC PDP 11/23 computer. The data are recorded directly onto a 9-track magnetic data tape which stores a maximum of four days worth of data on each tape. The ADCP runs continuously and writes an averaged data record to tape every minute. Each data record contains the time, the one-minute average of east (U) and north (V) velocity components from each bin, all navigation data received during the averaging period, water temperature at the depth of the recorded time, and a list of system parameters.

### 3. NAVIGATION

Navigation sensors used aboard the NOAA Ship MALCOLM BALDRIGE to calculate ship velocity and position were the TRANSIT Satellite System (SATNAV) and LORAN-C. A brief summary of each follows.

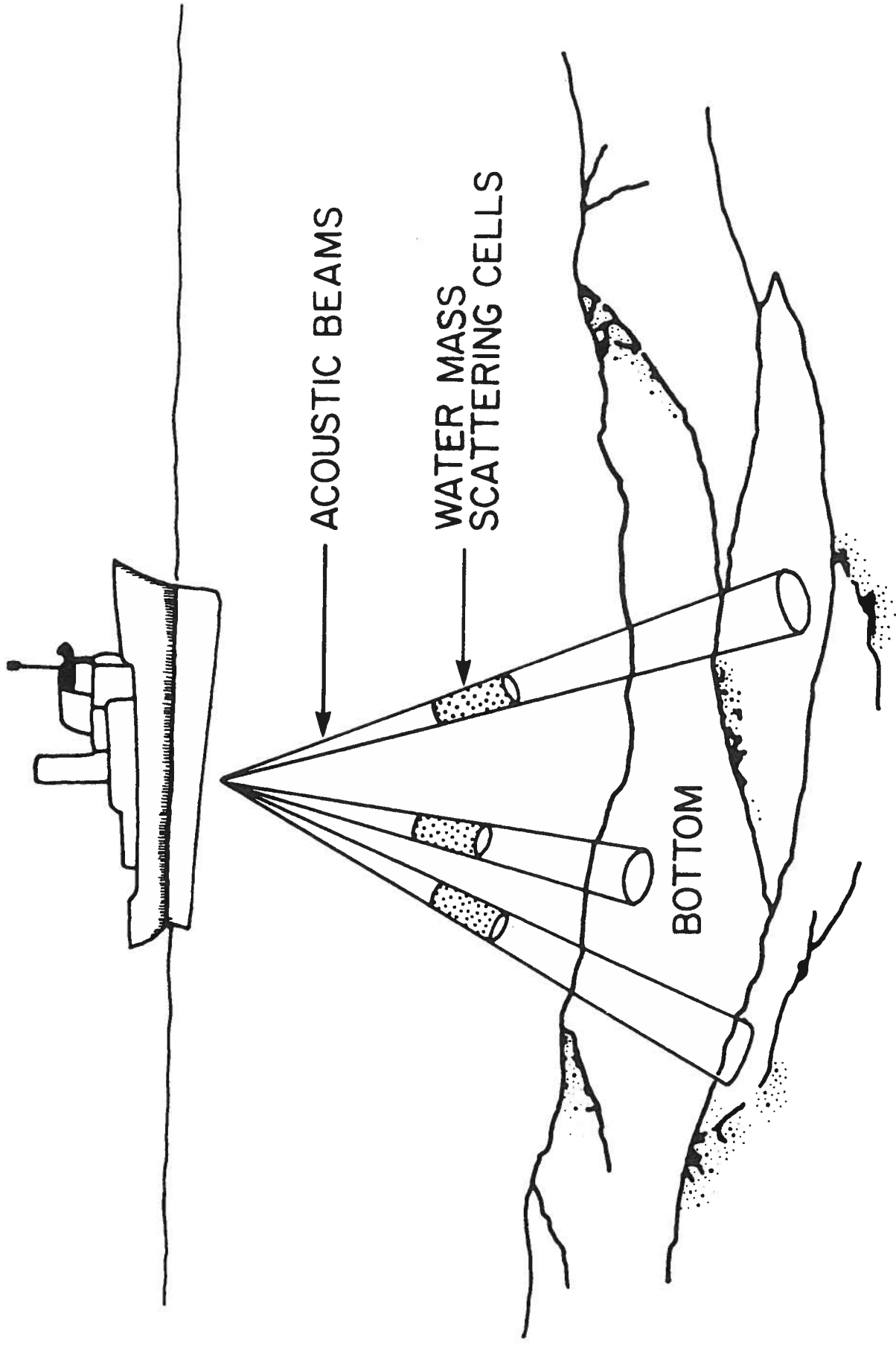

Figure 1. Schematic diagram of acoustic pulse travel from acoustic Doppler current profiler.

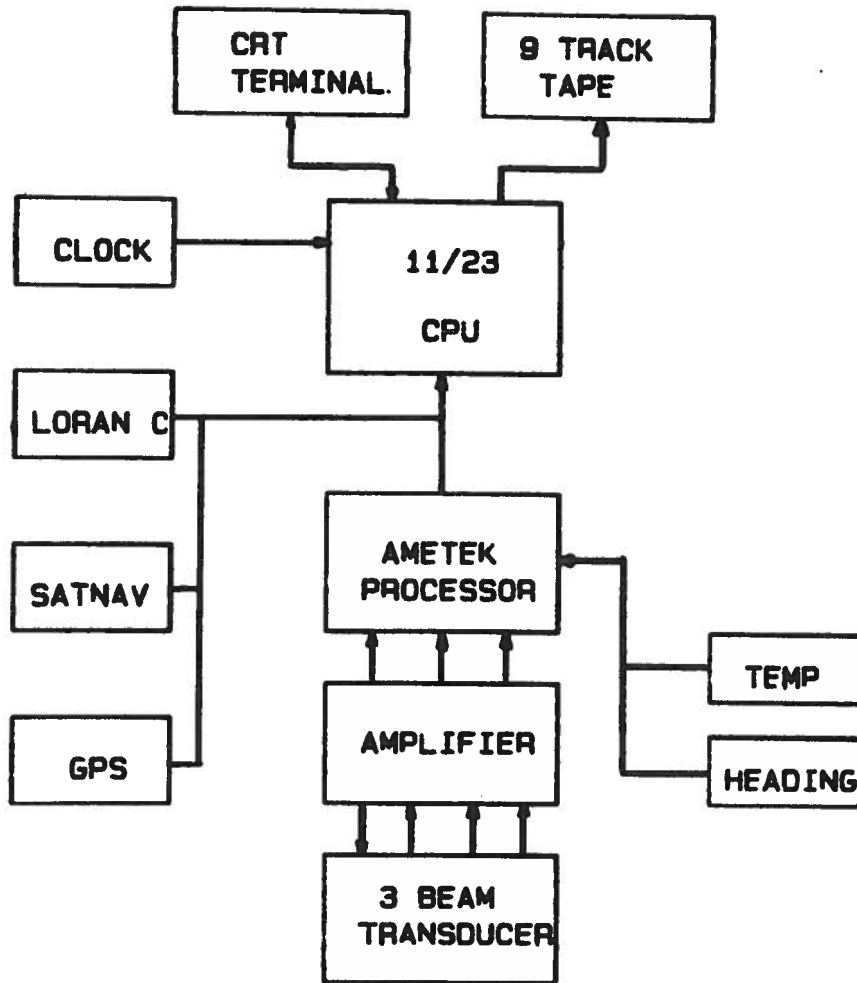

Figure 2. Diagram of shipboard data acquisition system linked with the Ametek-Straza profile.

## A. SATNAV

Of the three navigation systems available aboard the MALCOLM BALDRIGE, the TRANSIT Satellite System (SATNAV) is the only one universally operational 24 hours a day. All SATNAV fixes are received and stored in a data record by the ADCP. The data record contains the fix time, the fix position, the number of iterations needed to compute each position, and the elevation of the satellite.

Position estimates provided by SATNAV are not continuous; therefore, the ship velocity measurements can only be computed as averages over the interval between the incoming fixes, somewhere around 30 to 120 minutes. It should be noted that this method lacks the spatial resolution required for rapid transects through high horizontal shear regions. This is a major drawback when using only satellite navigation data.

Each pair of SATNAV fixes produces a mean ship velocity (relative to the earth) over the interval between fixes. Averaging ADCP shear relative to some depth (typically 200 m) over the same interval provides the mean ship speed relative to that level. The vector difference is the mean absolute velocity of the currents of the reference level. The reference level mean value is added to each one-minute shear profile, and these absolute ship speed estimates are integrated to provide position estimates for each profile. Although this method works well, it has its drawbacks, e.g., a bad satellite fix can produce large errors in reference velocities. In an effort to reduce the chances of producing faulty velocities, the following situations cause the fixes to be rejected:

- (1) Too low or too high elevation (less than  $10^\circ$  or greater than  $80^\circ$ ).
- (2) The SATNAV receiver takes more than five iterations to compute the fix.
- (3) The fix is obtained less than 18 minutes after an earlier good fix. This keeps the uncertainties of the velocity estimates below 70 cm/s.

Reference level velocities are spline fitted or averaged in space or time to produce a smooth field. Transducer misalignment can cause a bias in reference level velocities and therefore must be corrected before final calculations are produced independent of navigation used.

## B. LORAN-C

LORAN is an acronym for Long Range Navigation. This system uses shore-based radio transmitters and shipboard receivers to compute positions when at sea. Shore-based transmitters limit the range of the signals emitted; therefore, LORAN-C usage as a navigation source is generally limited to within several hundred miles of the coast. Large distances between the transmitting station and the shipboard receiver yield inaccurate fixes.

Following is a summary, taken from the U.S. Coast Guard publication, The LORAN-C Users Handbook, of how LORAN works.

A chain of three to five land-based transmitting stations separated by several hundred miles is established. Within the chain, one station is designated as the master station (M) and the other stations are designated as secondary stations. The master station and each secondary station transmit



synchronized pulses at precise time intervals. The on-board LORAN-C receiver measures the slight difference in time that it takes for these pulsed signals to reach the ship from each pair of transmitters. Each time difference (TD) is measured in microseconds (millionth of a second) and is then displayed as a readout on the LORAN-C receiver. Each time difference can be plotted on a LORAN-C overlaid NOAA nautical chart as a line-of-position (LOP). The time difference between the master station and a particular secondary station will never be in the same range as the time differences between the same master and another nearby secondary station. The ship's nautical position is at the point where two LOP's intersect. This happens six times in the southeast United States. Each intersection denotes a TD-pair. All secondary stations are not equal. Depending on a ship's location, some secondary stations offer a greater potential for accurate navigation than do the other stations.

Most of the ADCP data obtained during the cruises covered in this report were outside of the LORAN range. In cases where this navigation source was used for reference velocities, the data plots have been noted accordingly.

#### 4. CALIBRATION

This section briefly describes the process by which the transducer misalignment relative to the ship's hull and gyrocompass was determined. For more detailed information on calibration procedures aboard the MALCOLM BALDRIGE refer to Wilson et al. (1988).

In brief, the procedure involves making several runs at various speeds and directions over bottom depths less than 200 m. During each of these runs the distance traveled over the seafloor was computed from the measured velocity in the bottom track mode and then compared to the positions obtained from the ship's LORAN-C navigation. Table 2 lists results (Daubin, 1983) obtained during several runs after correction for the transducer misalignment were included. They concluded from these tests that velocities over the bottom compare favorably with those derived from the LORAN-C in three out of four cases. The estimated error in the LORAN-C velocities is in the 5-10 cm/s<sup>2</sup> range.

Table 2

Ship speed measured by profiles versus speed computed from Loran-C (m/s)

$V_{fwd}$	$V_{stbd}$	$V_{total}$	$V_{Loran}$
2.183	.027	2.183	2.206
3.325	.109	3.327	3.416
2.785	1.327	3.085	3.063
2.514	1.645	3.004	2.770

#### 5. DATA PROCESSING

The data presented in this report uses SATNAV or LORAN-C reference velocities; LORAN-C reference velocities were used in those areas above 26°N latitude.

In the initial ADCP data processing stage, the data is transferred from the raw data tape created on the ship to a disk file on the VAX 11/785. The newly created disk file contains the time, shear and navigation data as well as some system parameters. The data is then run through a series of programs whereby corrections to the ADCP system clock are made, if necessary; the transducer misalignment error is corrected if this has not been previously done; and finally, the navigation data is run through a series of programs where it is further processed to reduce the error in shear profiles. Using the file containing the averaged data, a plot of U vs. record number and V vs. record number is created (see Figure 3, for example). This procedure is done to determine if there are any obvious outlying values which should be eliminated. After this is done, the data are then divided into sections. In the final step, the data for each section are then run through programs that set up and create the U and V plots exhibited in this report. The final product is displayed in Appendix A, a U and V current velocity plot for each section shown on the accompanying trackline map.

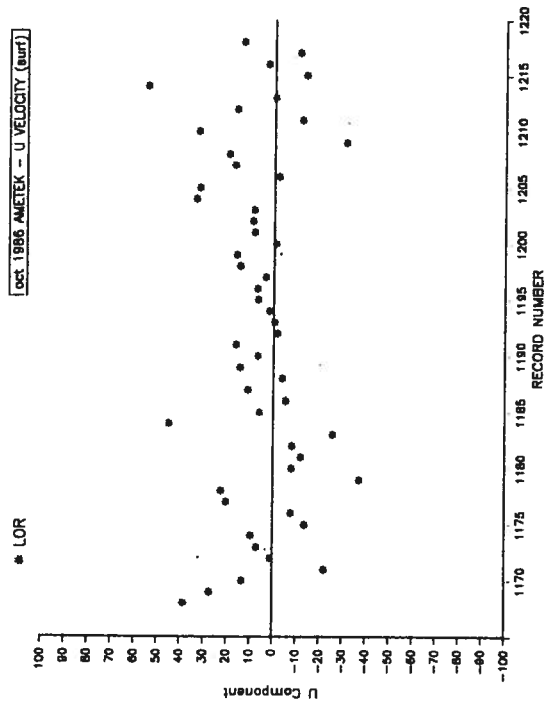
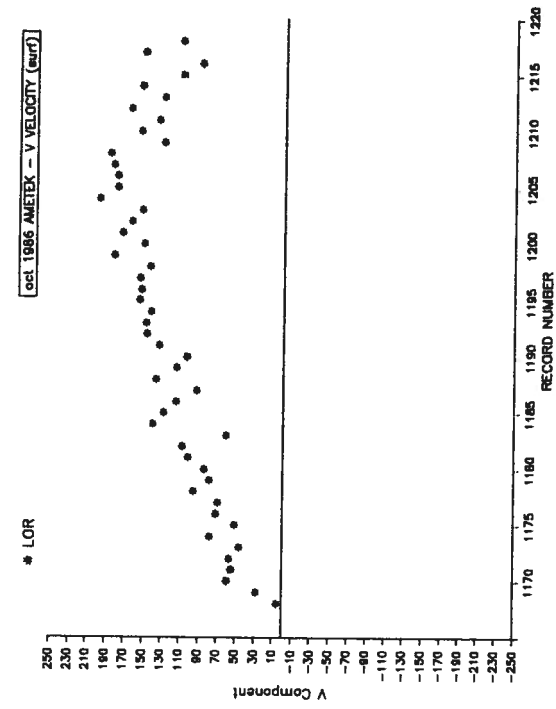

Figure 3. Example of U and V plots used in ADCP data editing.

## 6. REFERENCES

- Bitterman, D., and D. Wilson, 1983. Ocean current profiling with a shipboard Doppler acoustic backscatter system. Oceans '83, 1:27-31.
- Daubin, S., 1983. Effects of ship motion on the output of a tribeam acoustic Doppler current profiling system. Technical Report, DSC TR-02-83, Daubin Systems Corp., Key Biscayne, FL, 45 pp.
- Leaman, K. D., and P. S. Vertes, 1983. The Subtropical Atlantic Climate Study (STACS), 1982. Summary of RSMAS Pegasus observations in the Florida Straits. Technical Report, UM RSMAS No. 83012, 154 pp.
- Molinari, R. L., 1989. Subtropical Atlantic Climate Studies (STACS): An update. Oceanography, 32-35.
- Ratnaswamy, M. J., D. Wilson, and R. L. Molinari, 1985. Current velocity and hydrographic observations in the Straits of Florida: Subtropical Atlantic Climate Study (STACS), 1983 and 1984. NOAA Data Report, ERL AOML-5.
- Vertes, P. S., and K. D. Leaman, 1984. The Subtropical Atlantic Climate Study (STACS), 1983. Summary of RSMAS Pegasus observations in the Florida Straits. Technical Report, UM RSMAS No. 84002, 172 pp.
- Wilburn, A. M., E. Johns, and M. Bushnell, 1987a. Current velocity and hydrographic observations in the Straits of Florida, the Caribbean Sea and offshore of the Antillean Archipelago: Subtropical Atlantic Climate Studies (STACS), 1984 and 1985. NOAA Data Report, ERL AOML-8, 194 pp.
- Wilburn, A. M., E. Johns, and M. Bushnell, 1987b. Current velocity and hydrographic observations in the Straits of Florida, the Caribbean Sea and offshore of the Antillean Archipelago: Subtropical Atlantic Climate Studies (STACS), 1986. NOAA Data Report, ERL AOML-10, 247 pp.
- Wilburn, A. M., E. Johns, and M. Bushnell, 1988. Current velocity and hydrographic observations in the southwestern North Atlantic Ocean: Subtropical Atlantic Climate Studies (STACS), 1987. NOAA Data Report, ERL AOML-12, 86 pp.
- Williams, E. J., E. Marmolejo, D. Wilson, and R. L. Molinari, 1983. Current velocity profiles in the Straits of Florida from the Pegasus current profiler: Subtropical Atlantic Climate Study (STACS), 1982. NOAA Technical Memorandum ERL AOML-55, 181 pp.
- Wilson, D., C. Roffer, and D. Bitterman, 1988. The shipboard acoustic Doppler program at AOML. EOS, Trans. AGU, 67(44):1061.
- Wilson, D., and A. Leetmaa, 1988. Acoustic Doppler current profiling in the equatorial Pacific in 1984. J. Geophys. Res., 93:947-966.

## 7. ACKNOWLEDGMENTS

The authors wish to thank Robert L. Molinari for his contribution to the completion of this report, the following NOAA scientific and technical personnel, David Bitterman and Mark Bushnell for their comments, Cy Oggins (formerly of NOAA), who greatly assisted in the processing of the data, and Gail Derr for the great typing job.

### **Appendix A: ADCP U-V Velocity Plots**

Speeds are given in cm/s. Indicator (LORAN) denotes LORAN-C navigation used to reference velocity profiles. No indicator denotes SATNAV used to reference profiles.

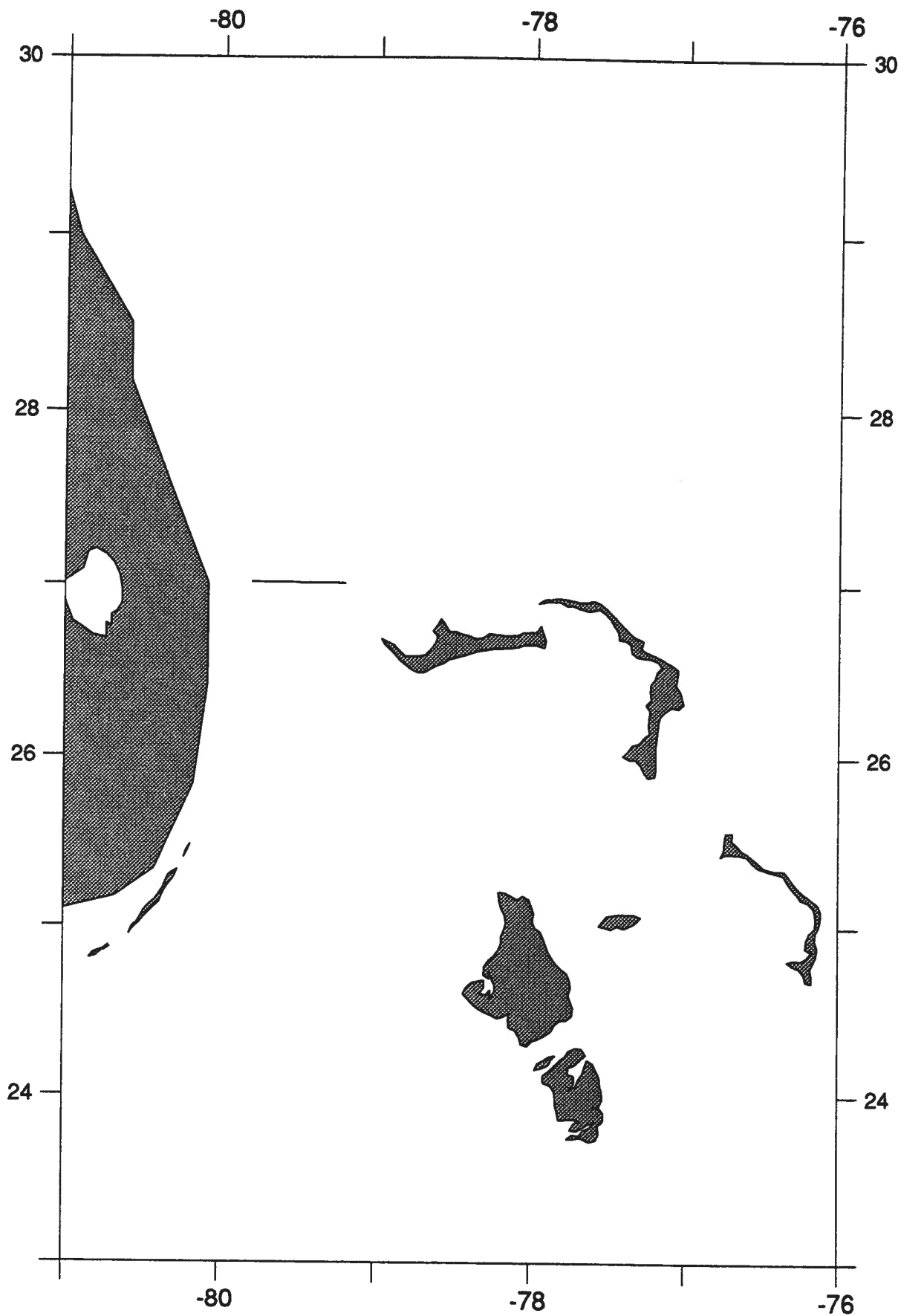

*Map of the Ametek-Straza (ADCP) trackline - December 1983*

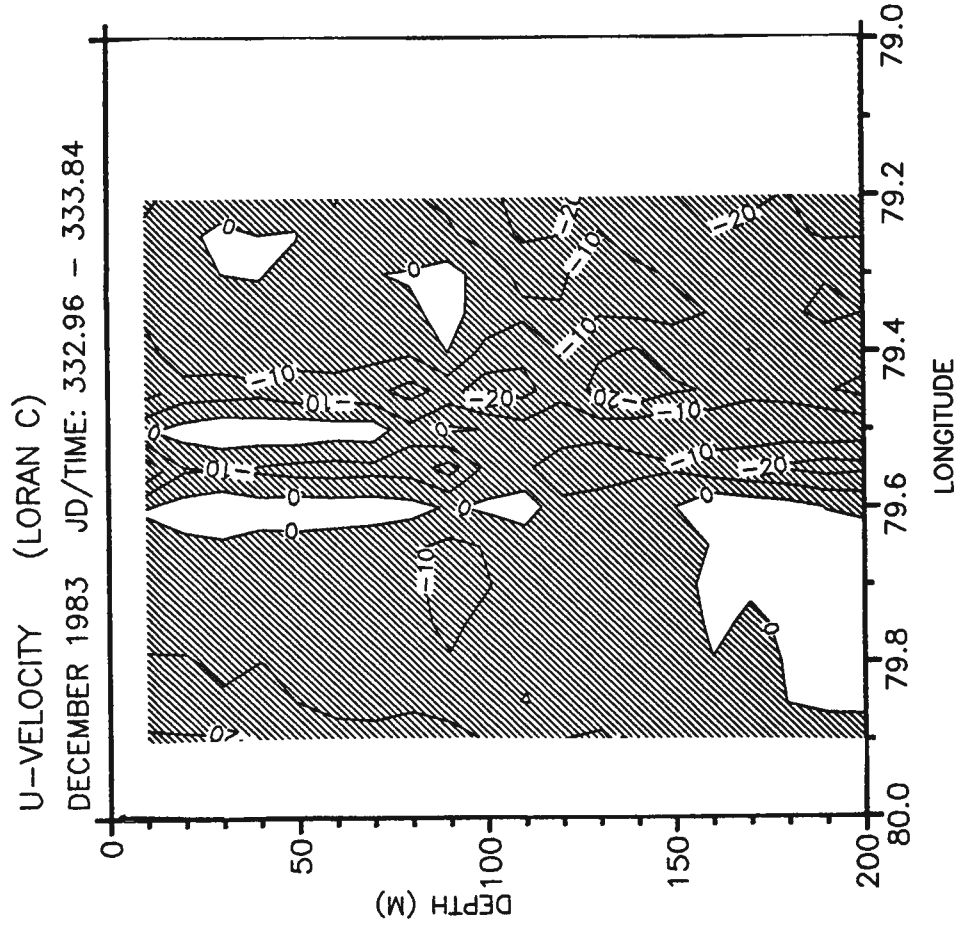
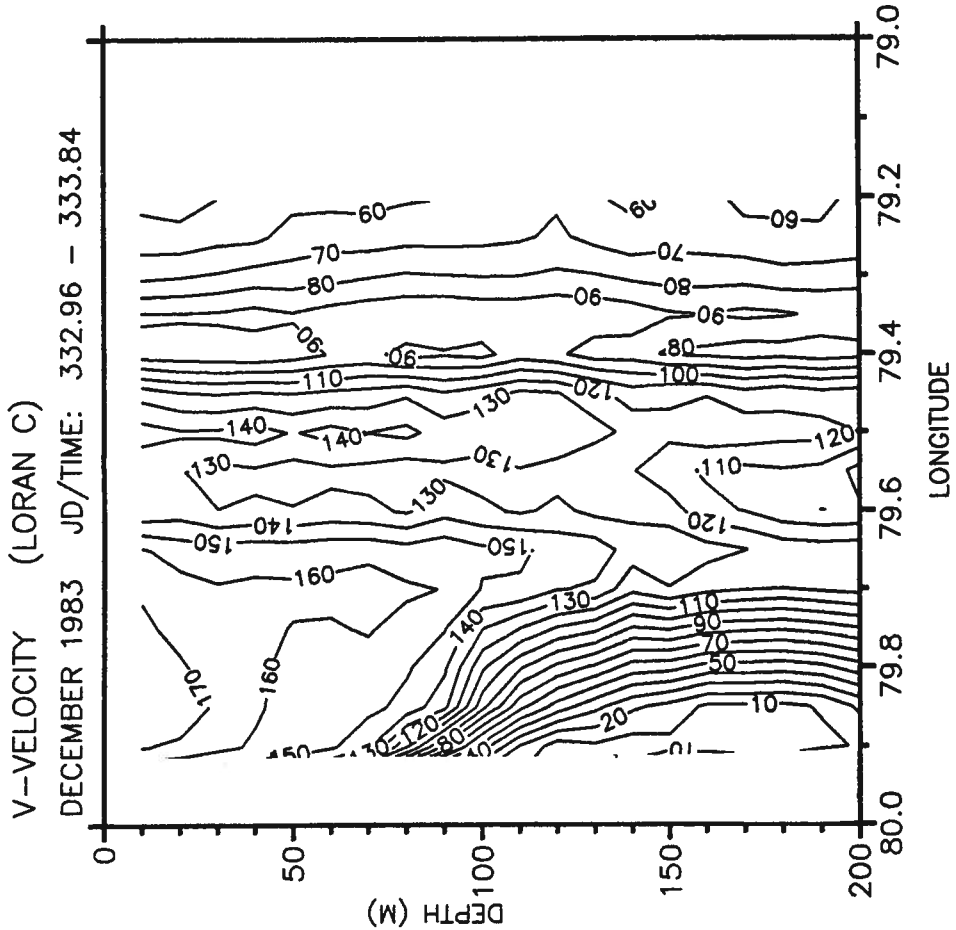



U-VELOCITY (LORAN C)  
 DECEMBER 1983 JD/TIME: 333.85 - 334.58

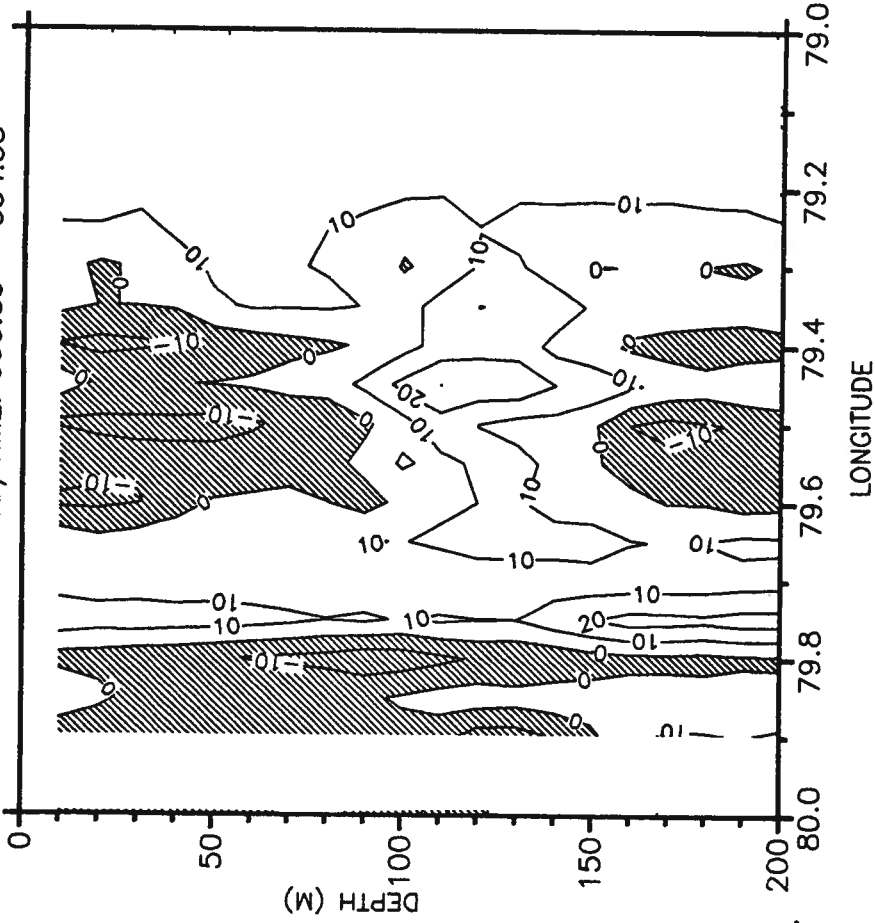

V-VELOCITY (LORAN C)  
 DECEMBER 1983 JD/TIME: 333.85 - 334.58

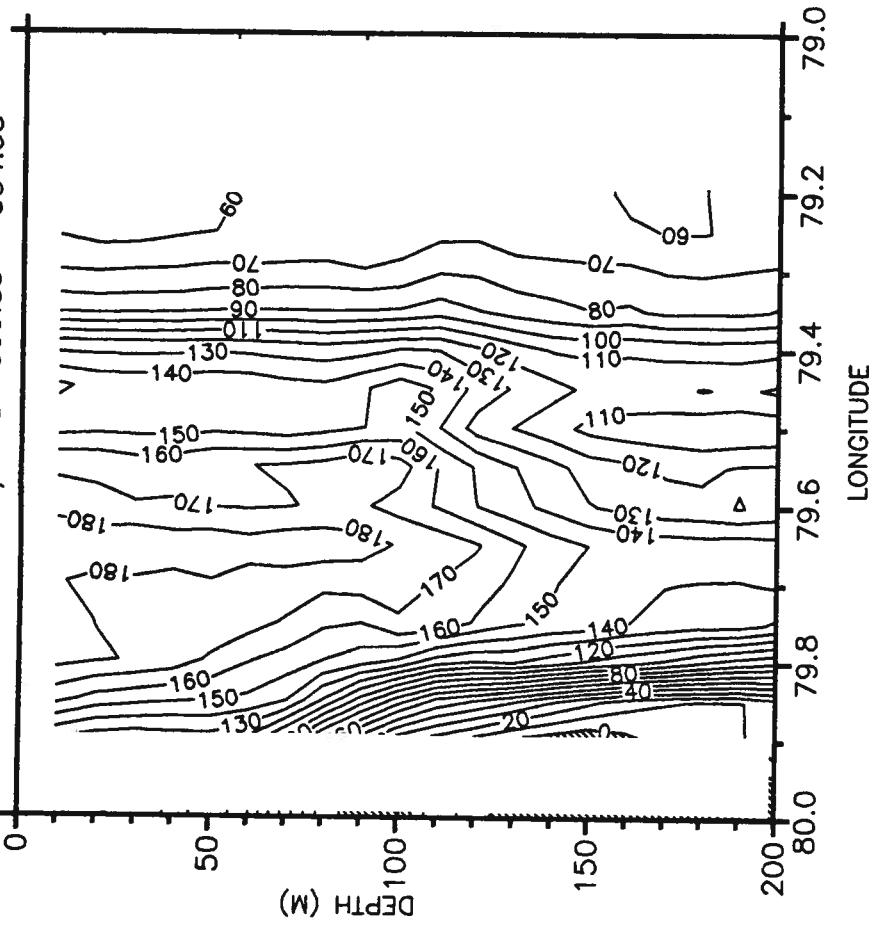

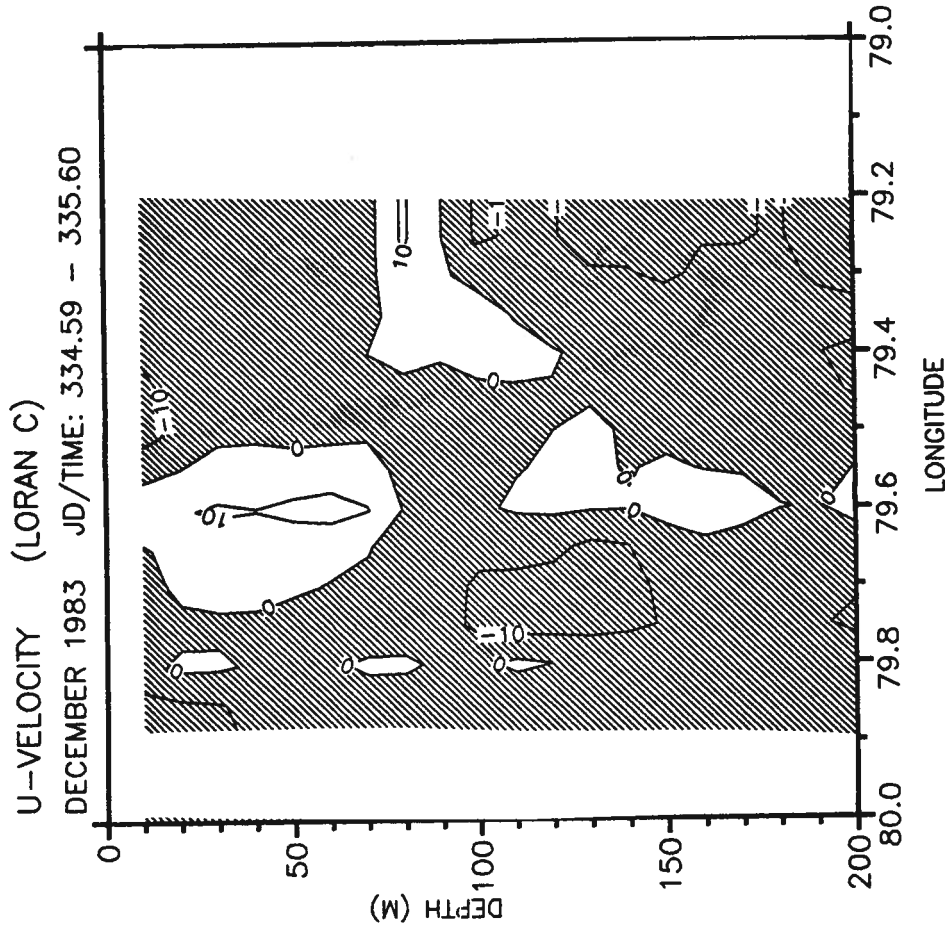
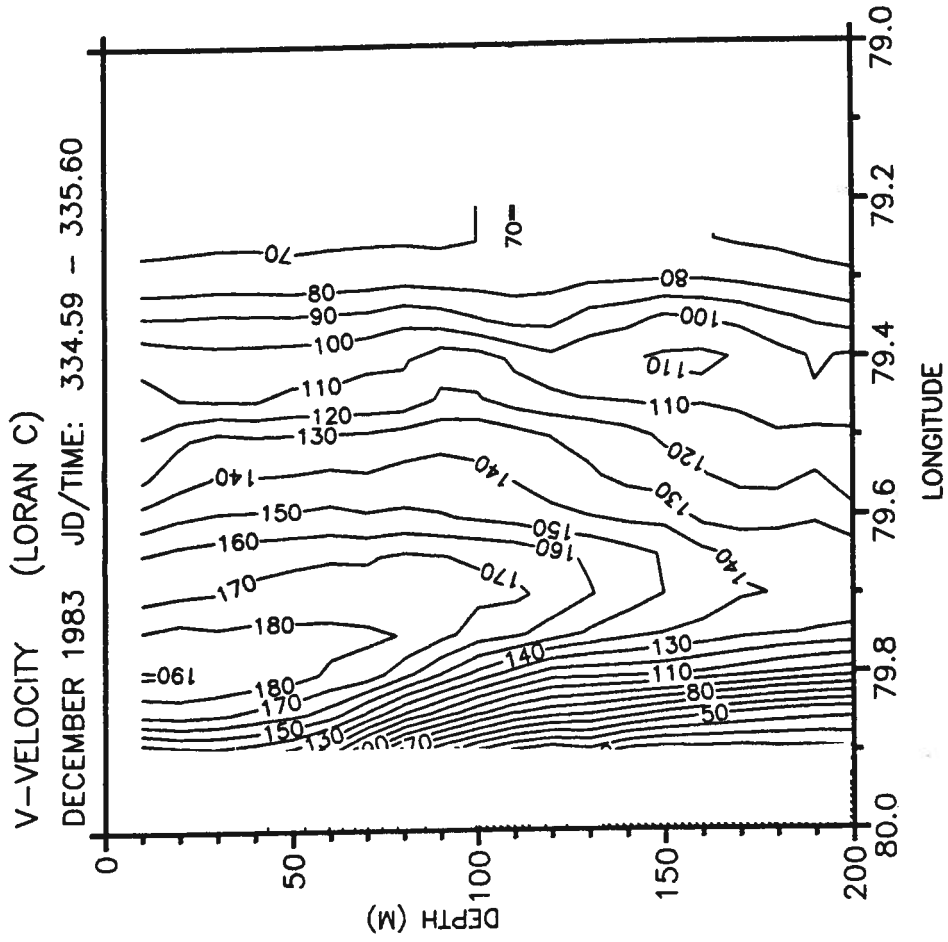

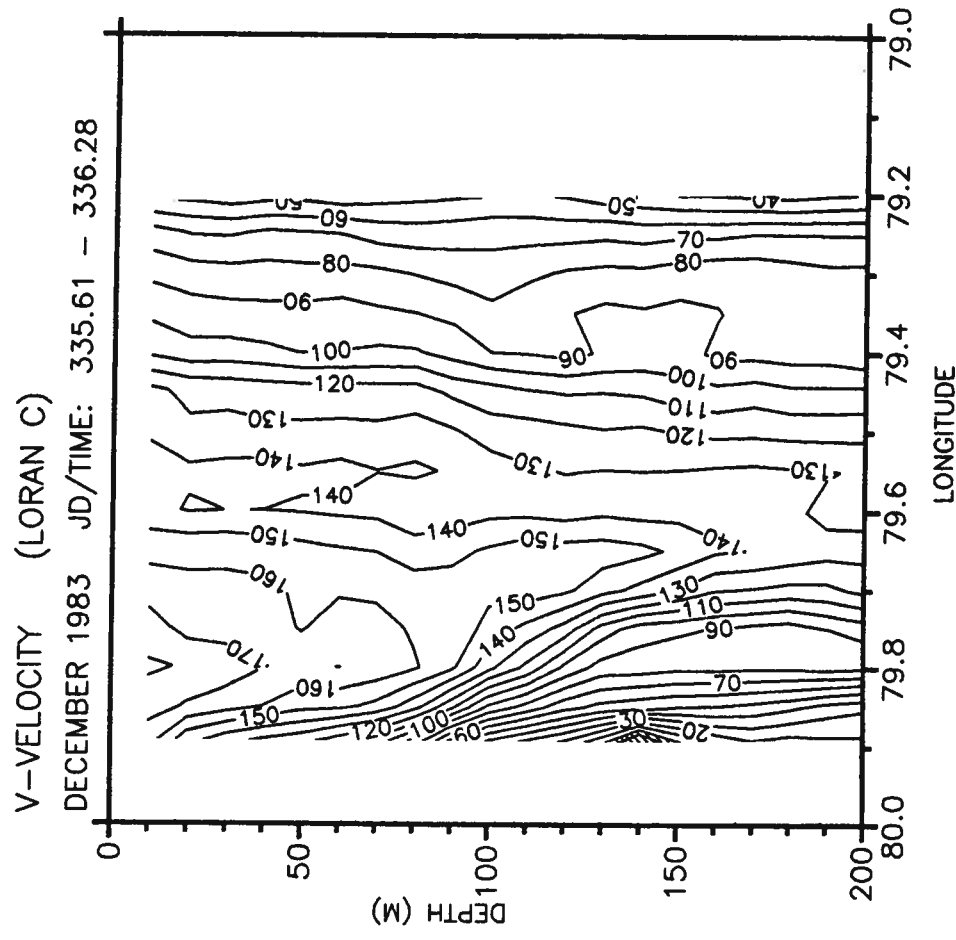
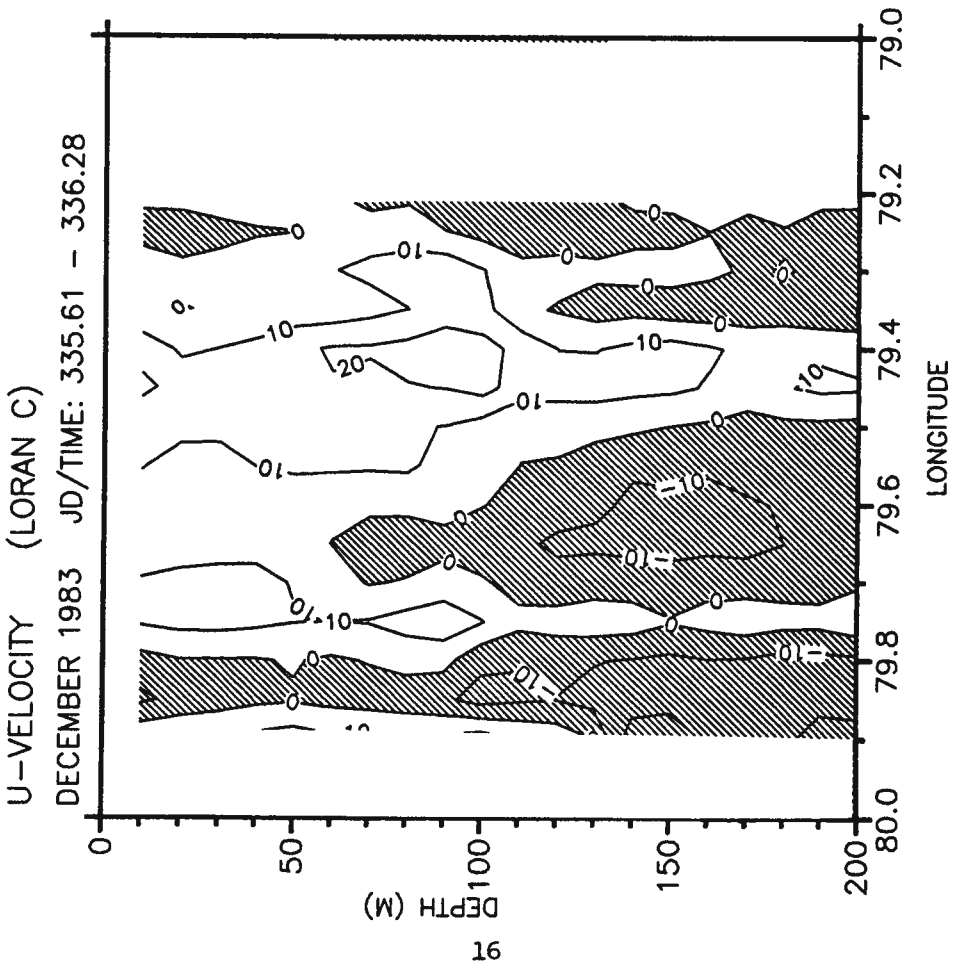

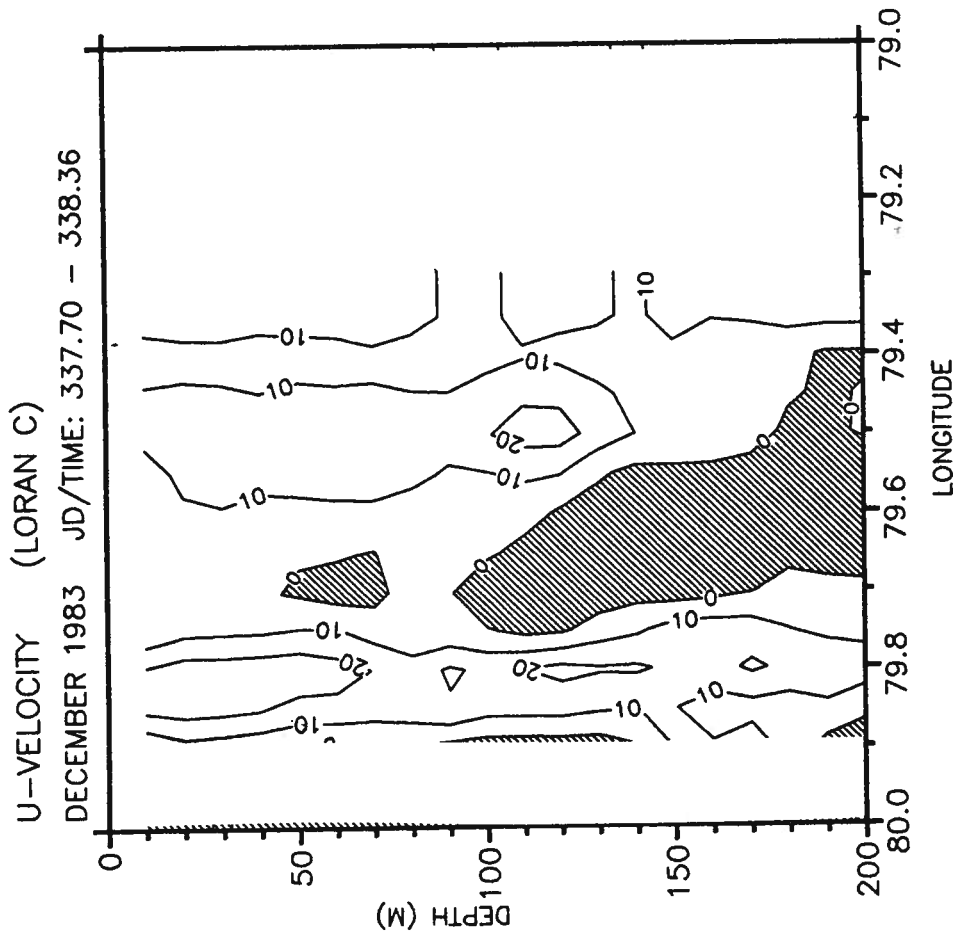
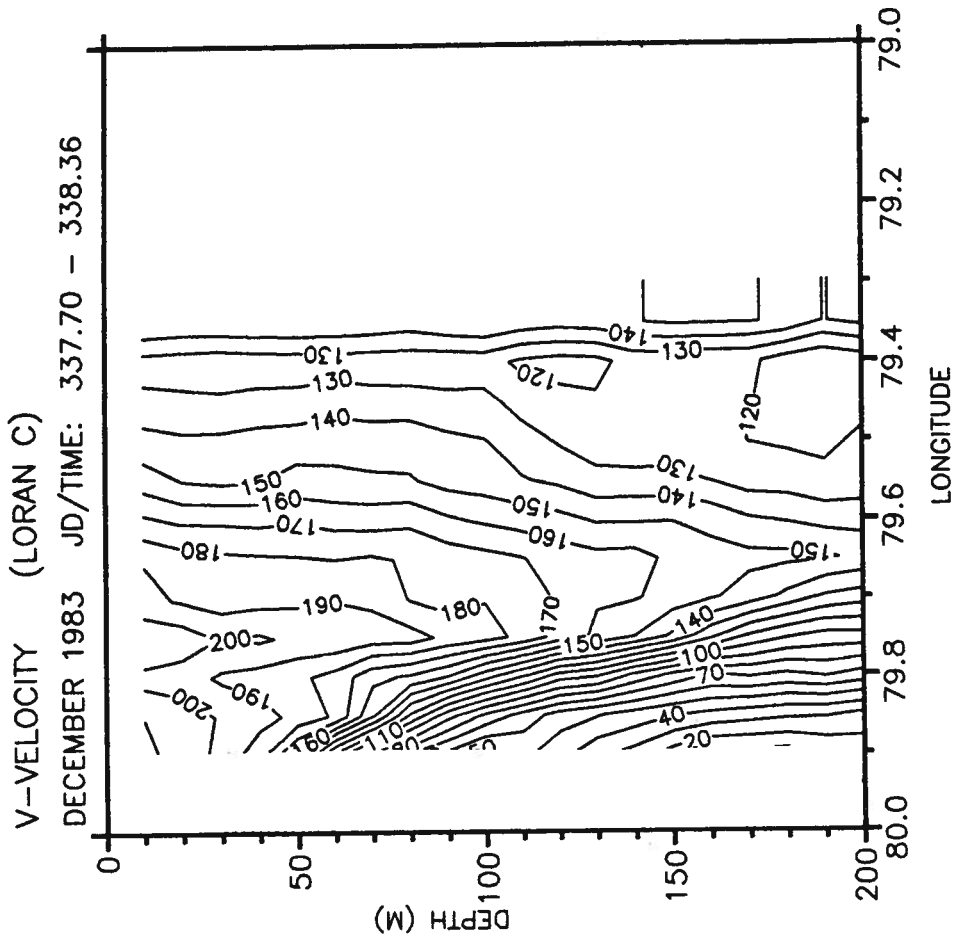

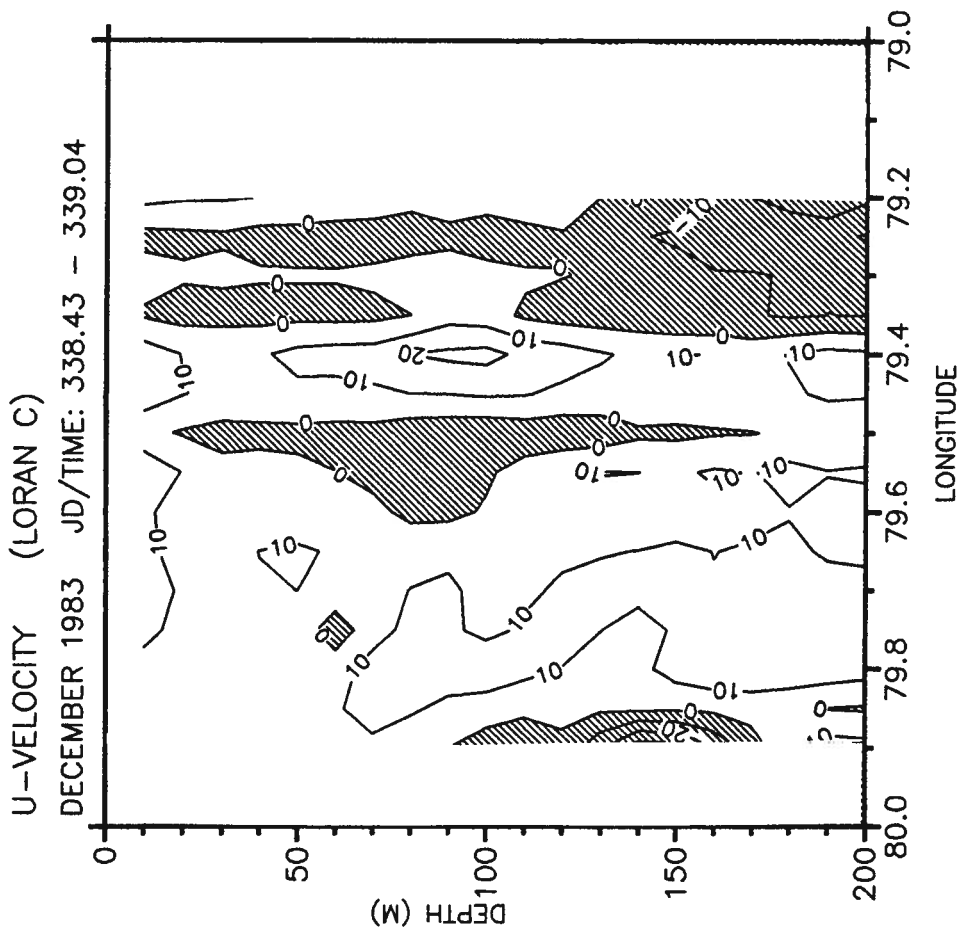
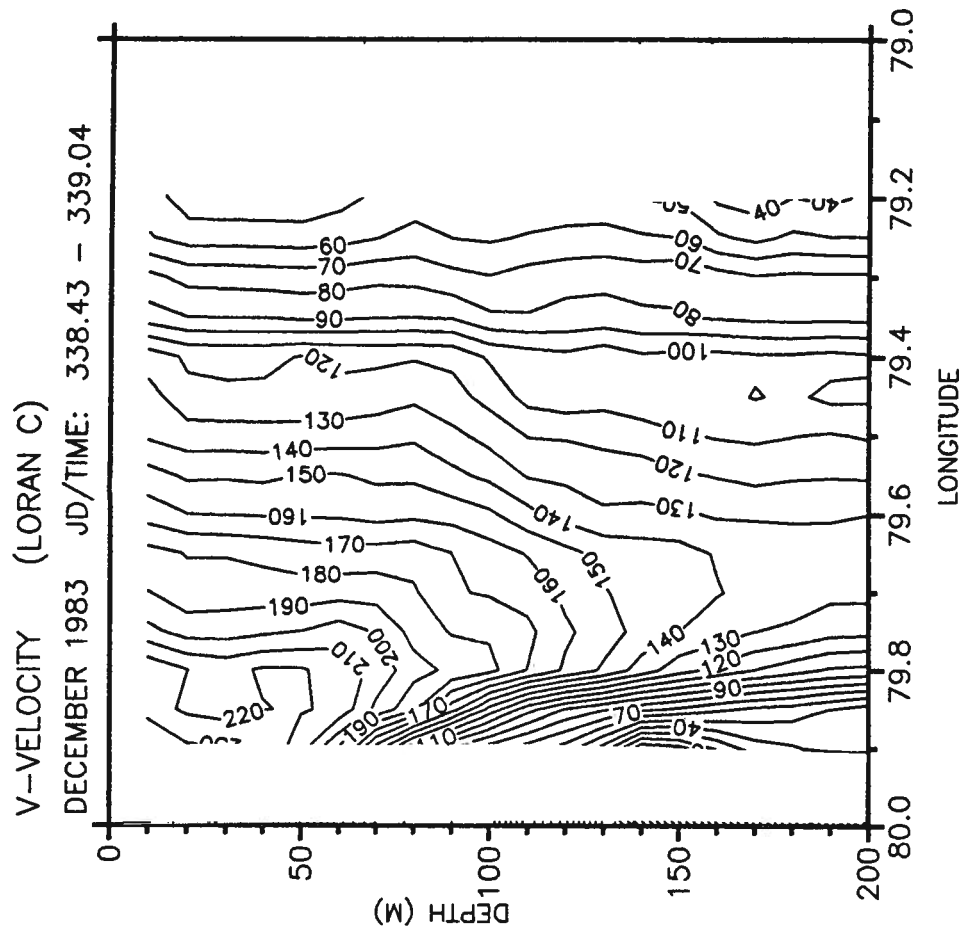

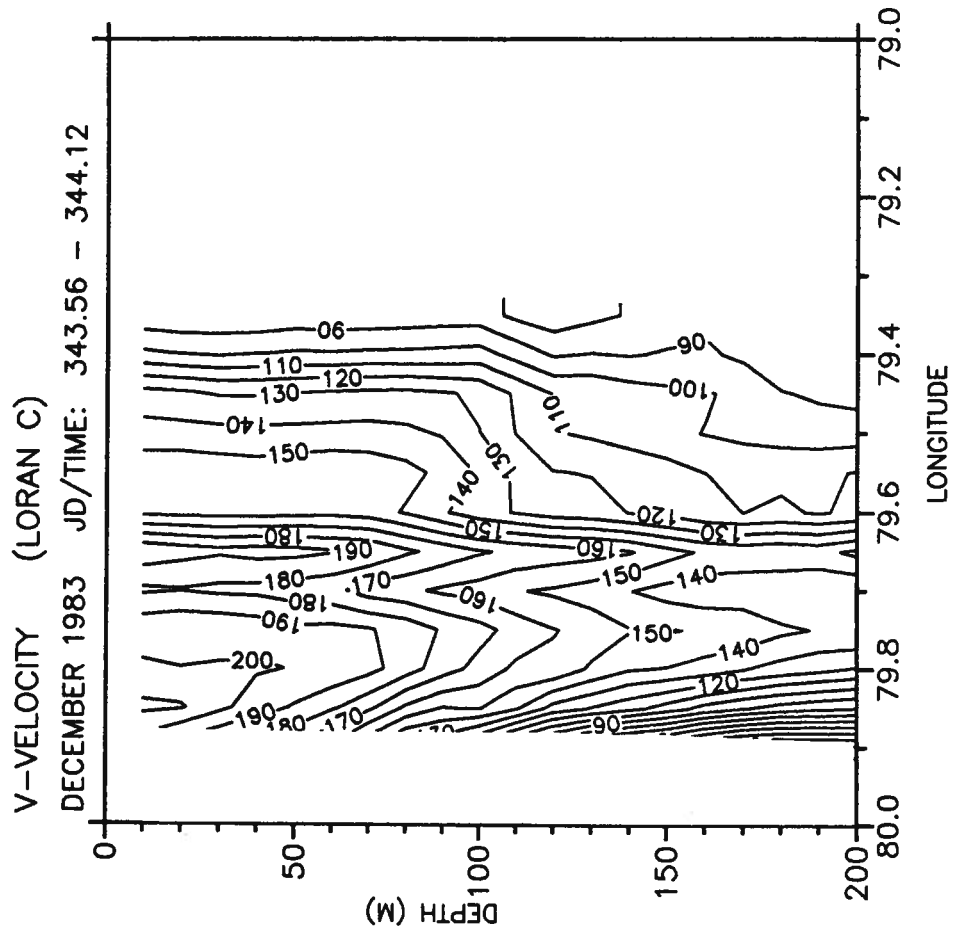
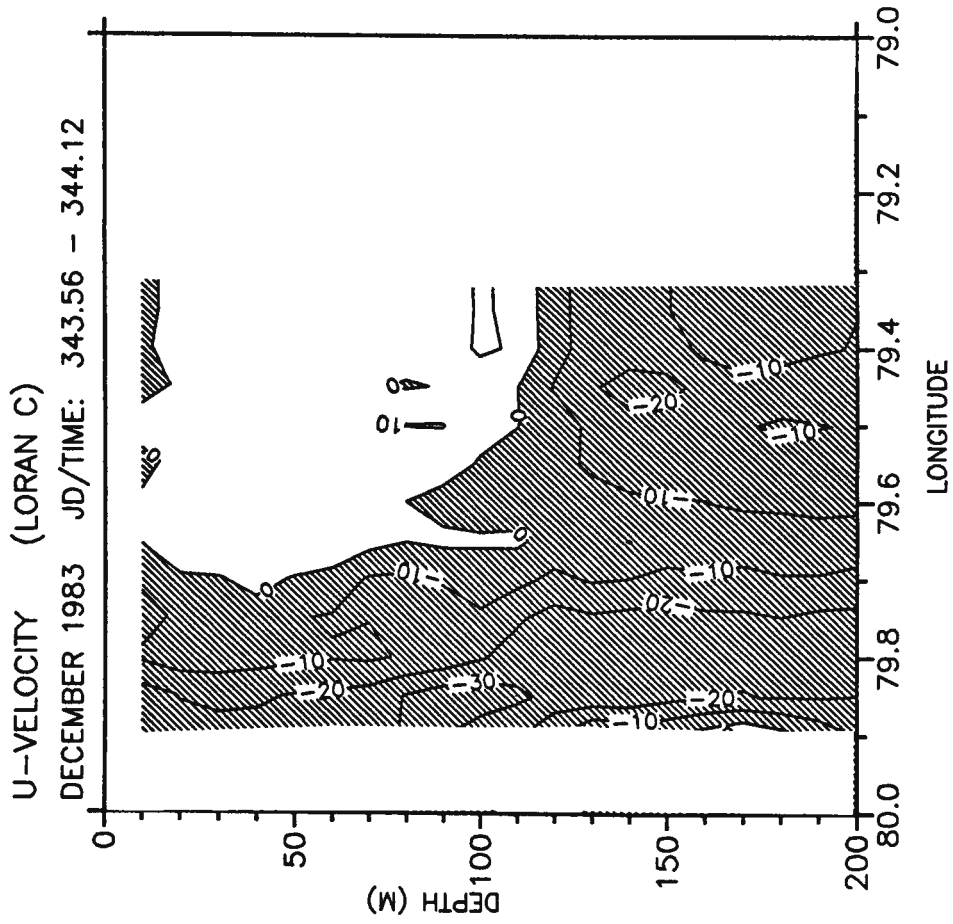

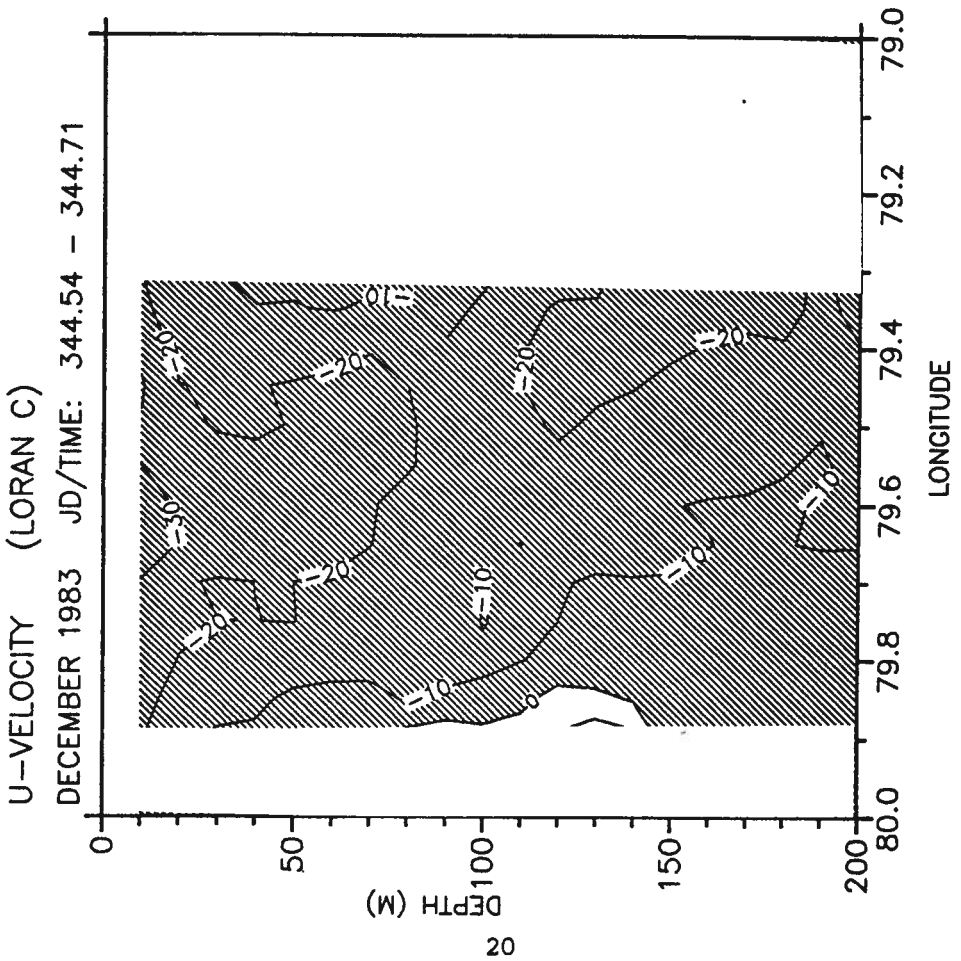
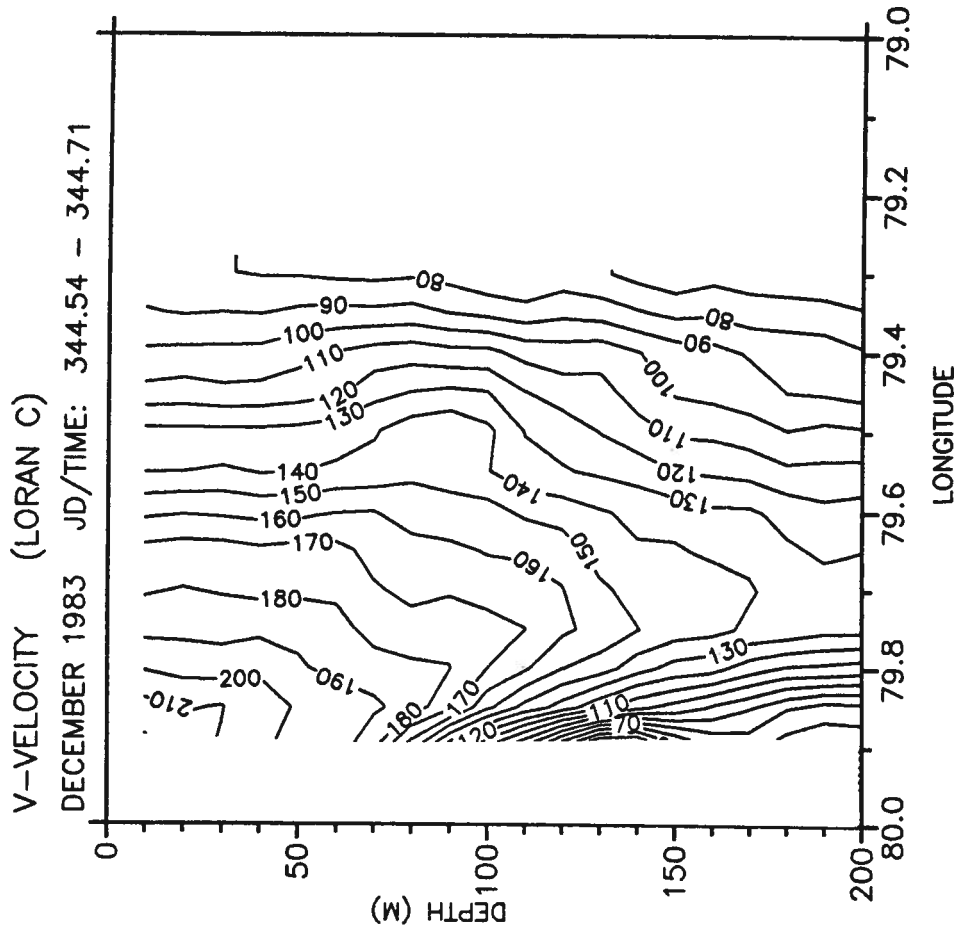

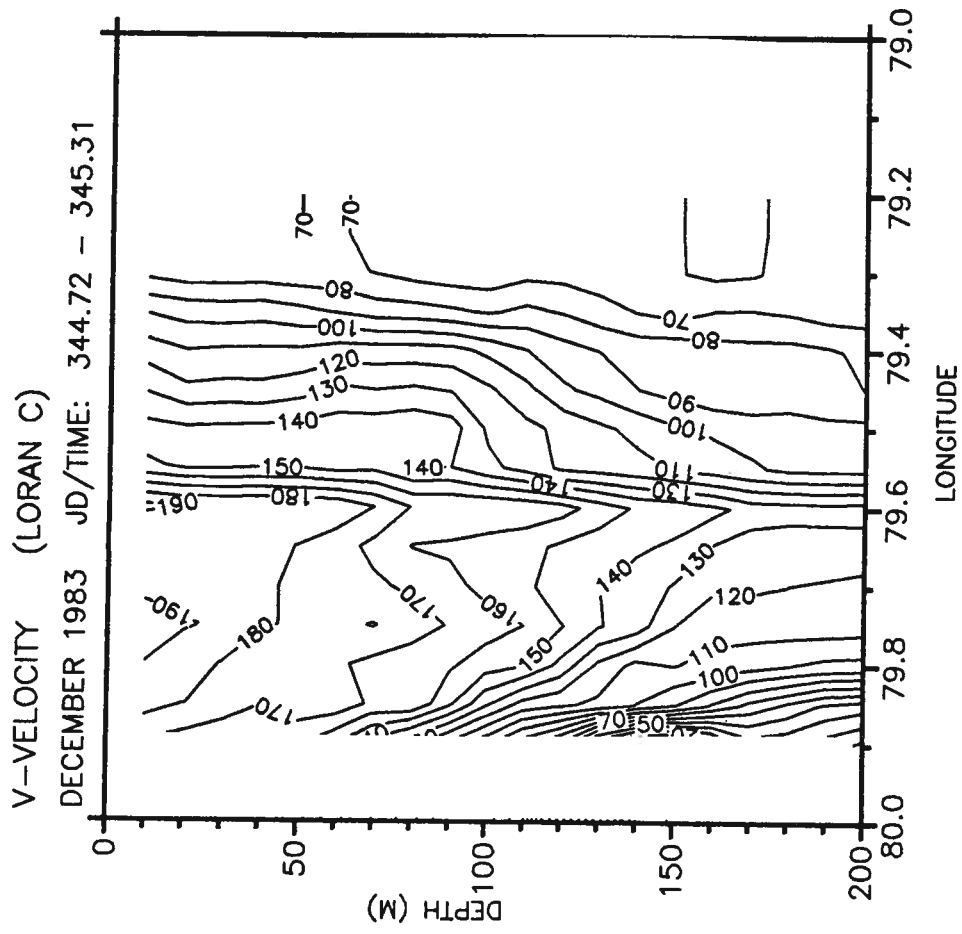
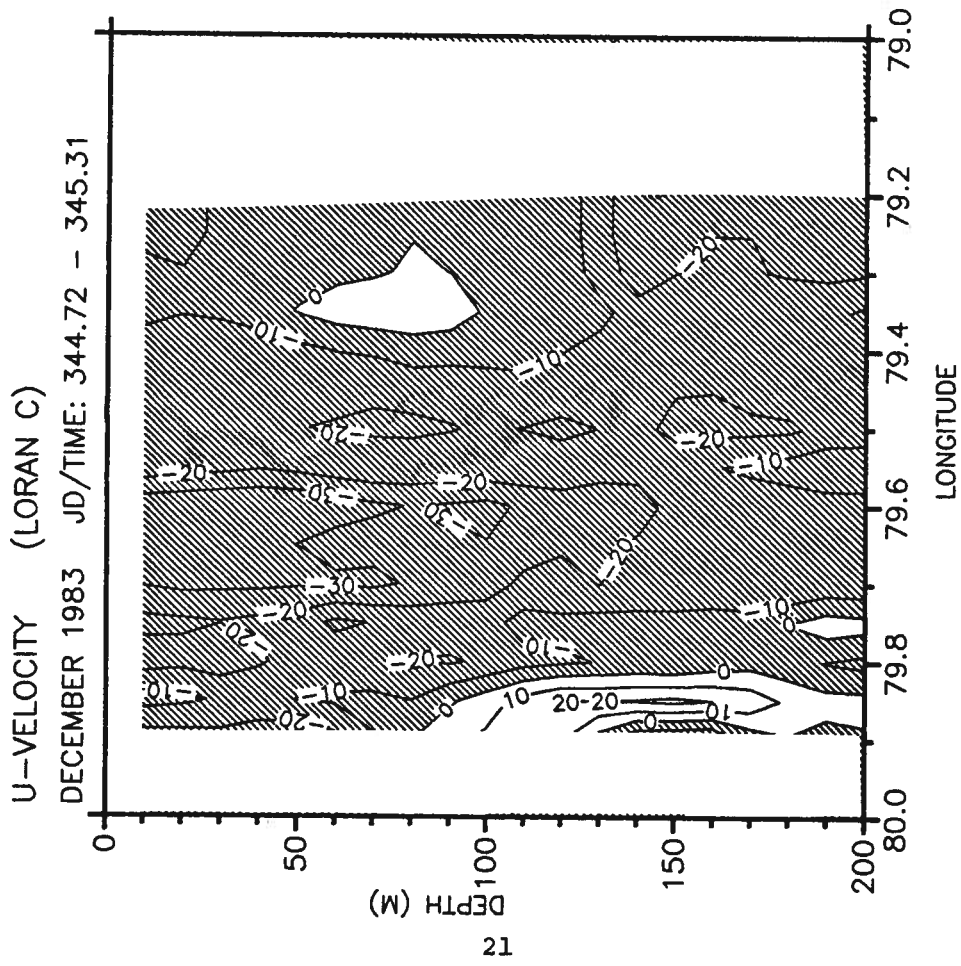



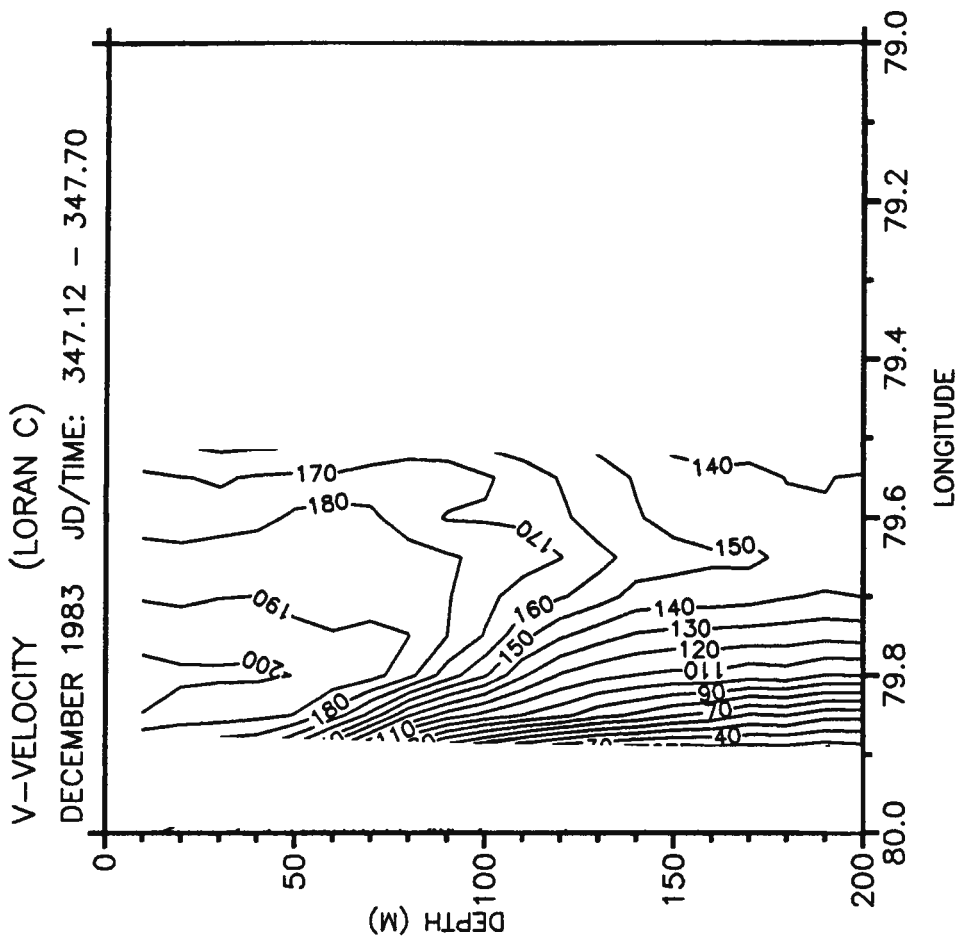
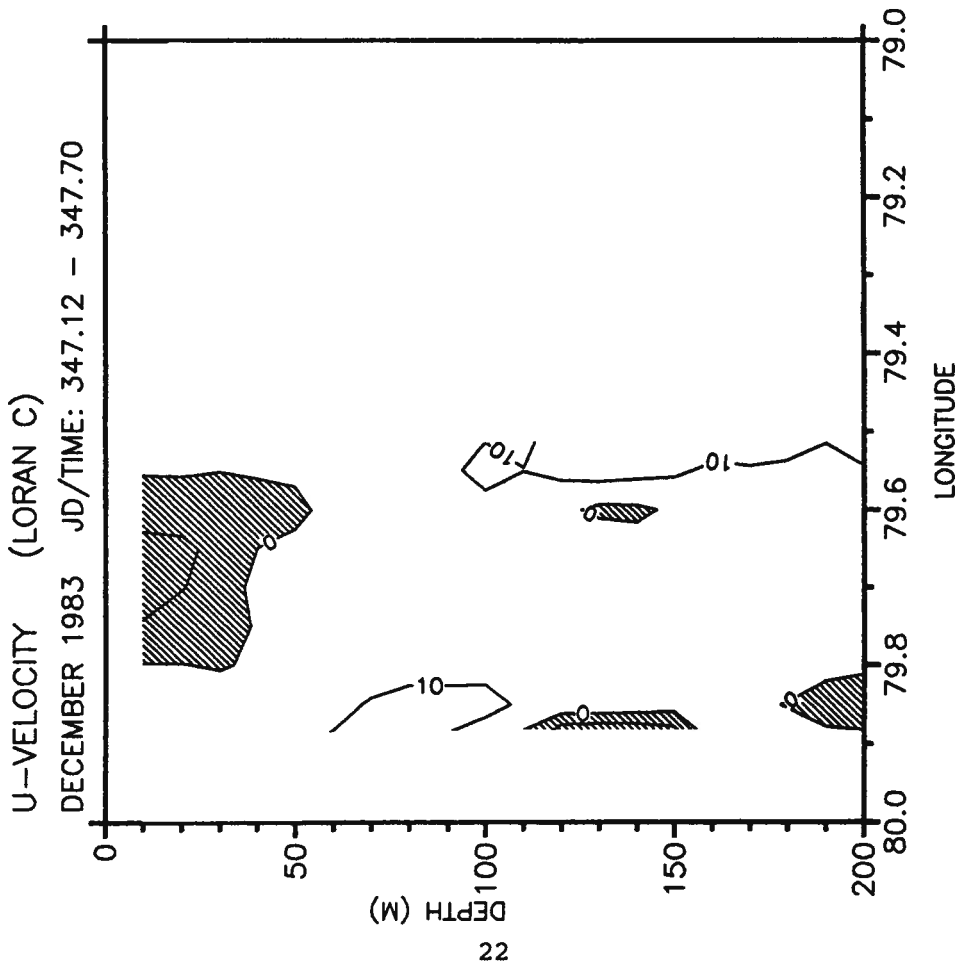

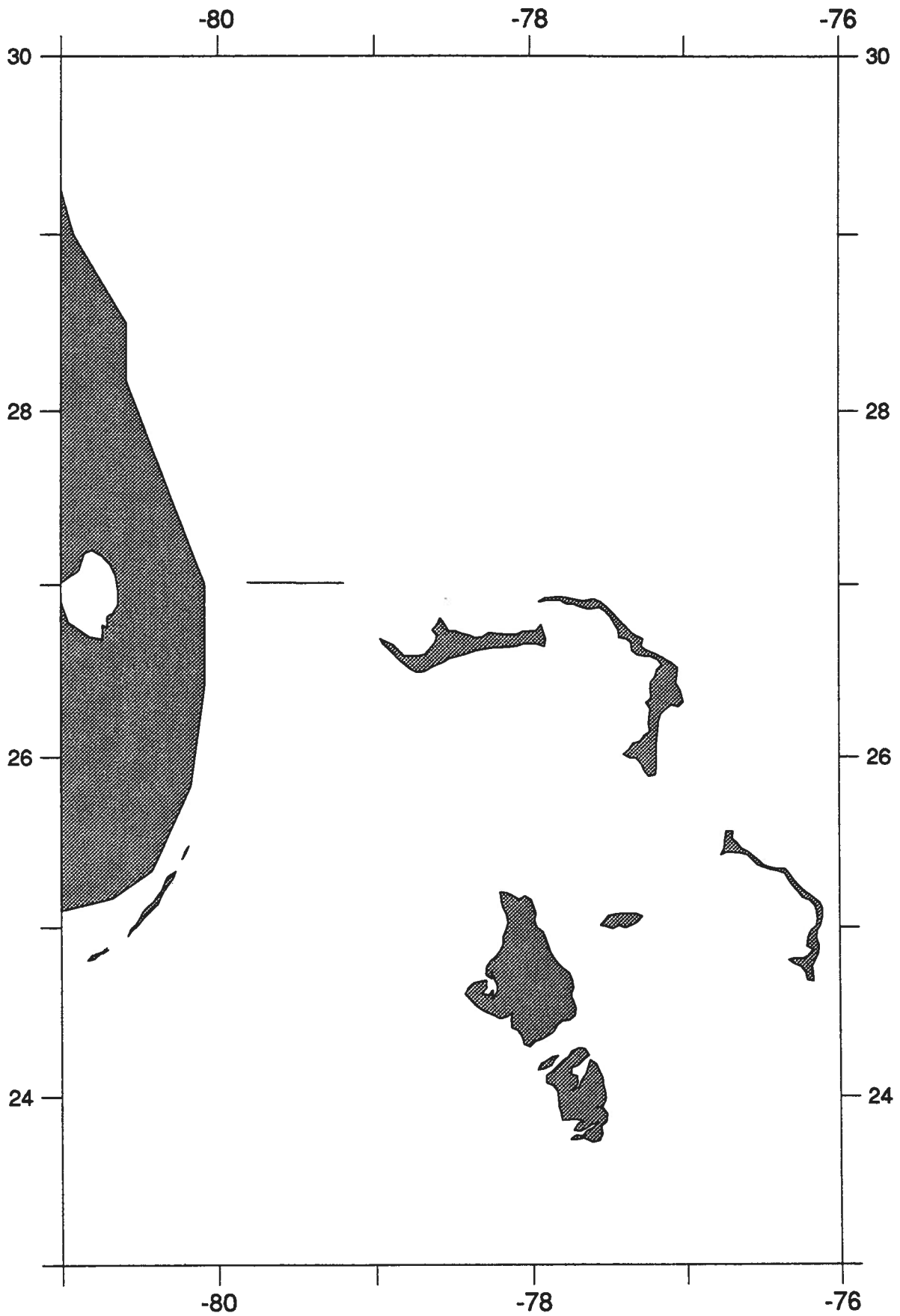

***Map of the Ametek-Straza (ADCP) trackline - March 1984***

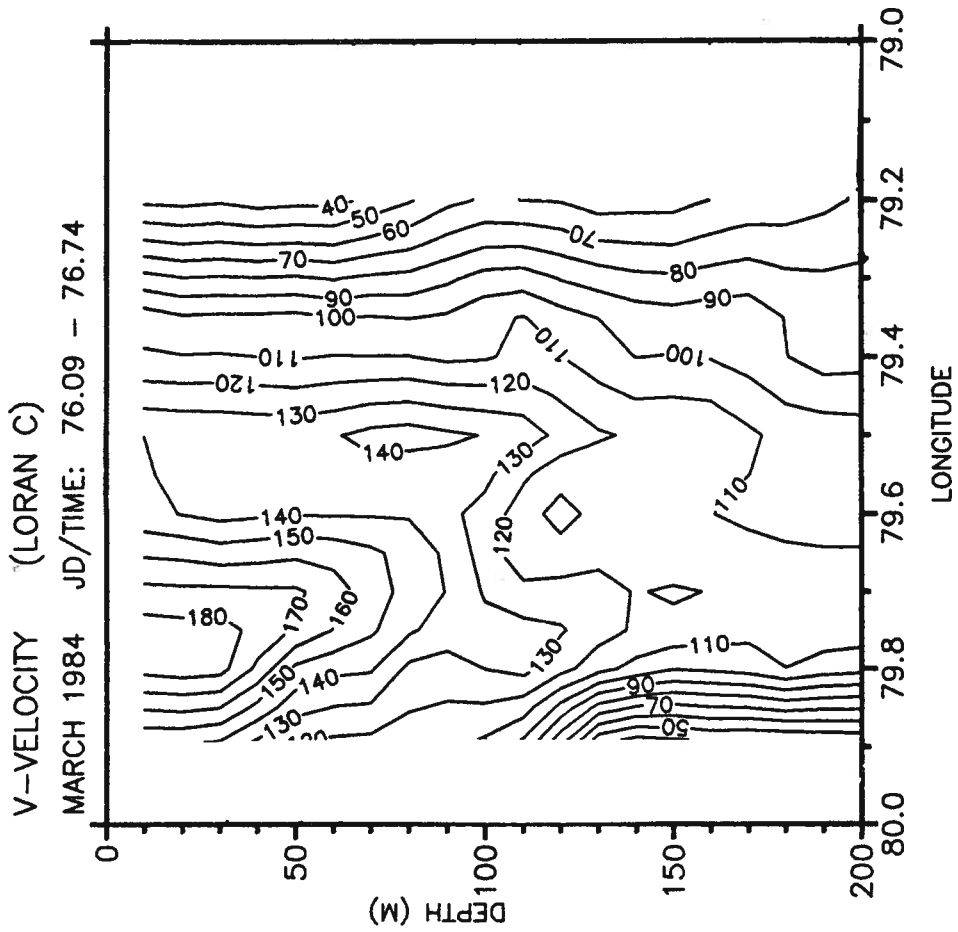
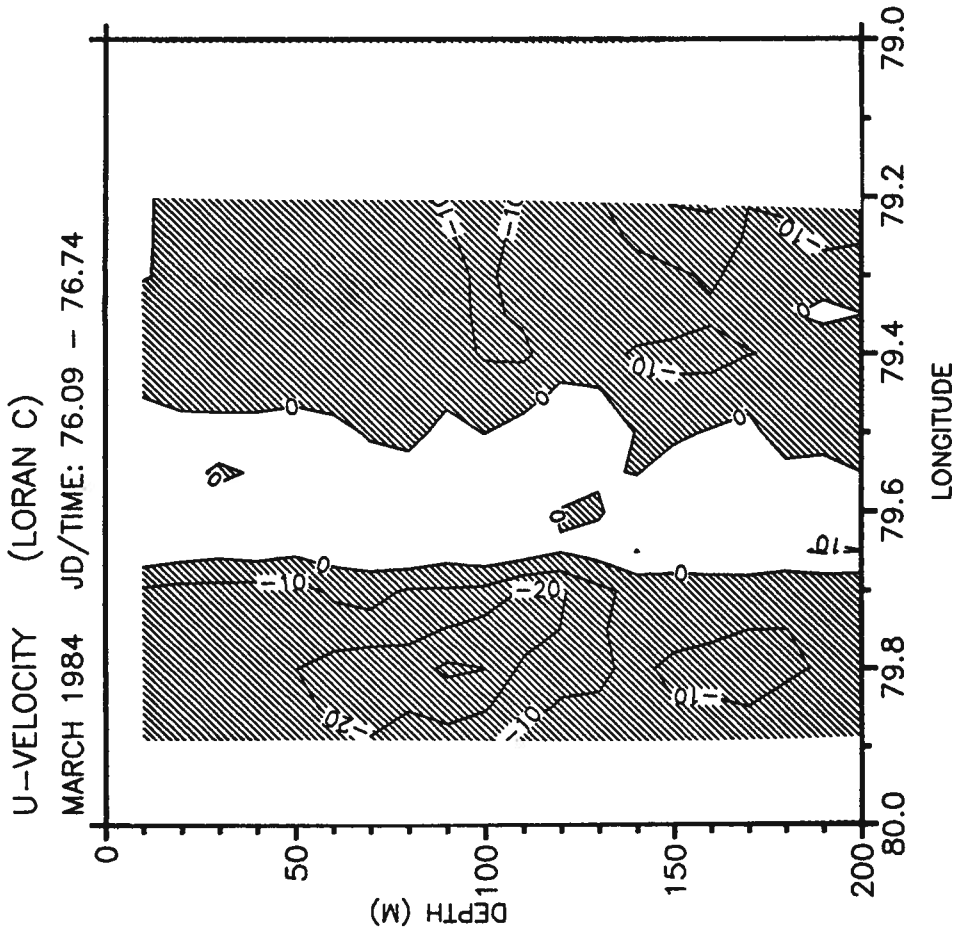

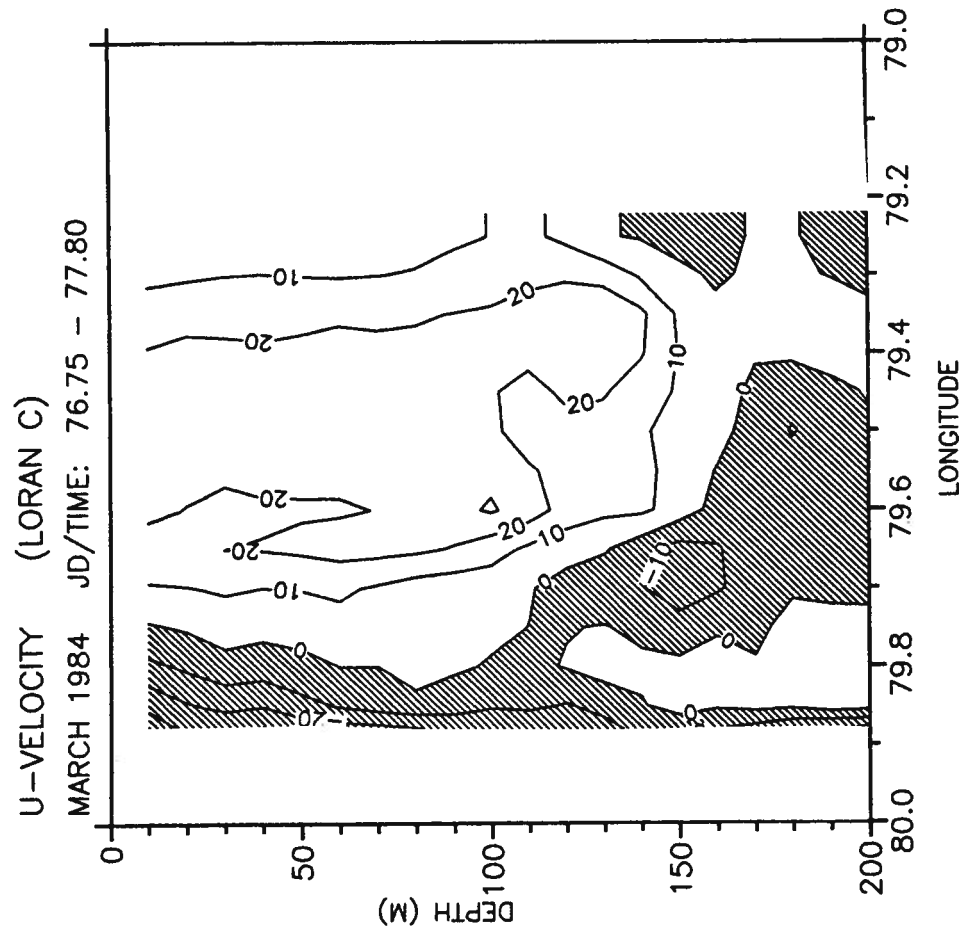
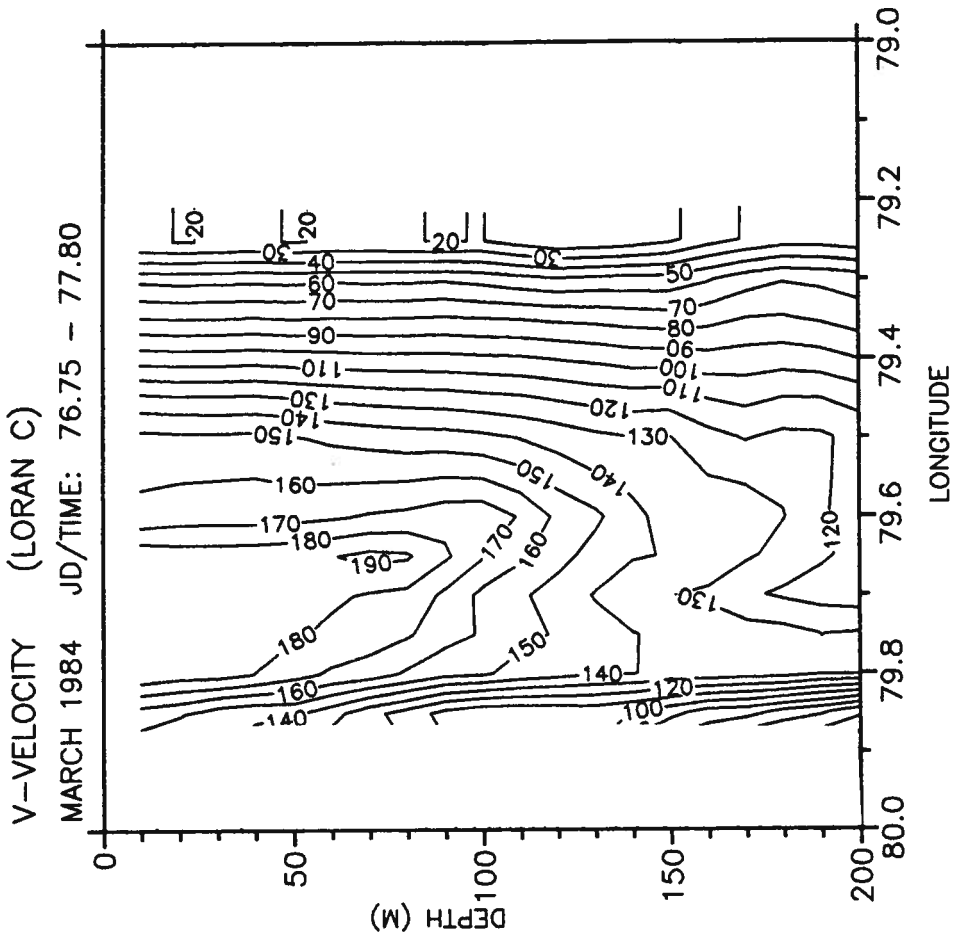

U-VELOCITY (LORAN C)  
MARCH 1984 JD/TIME: 79.27 - 79.82

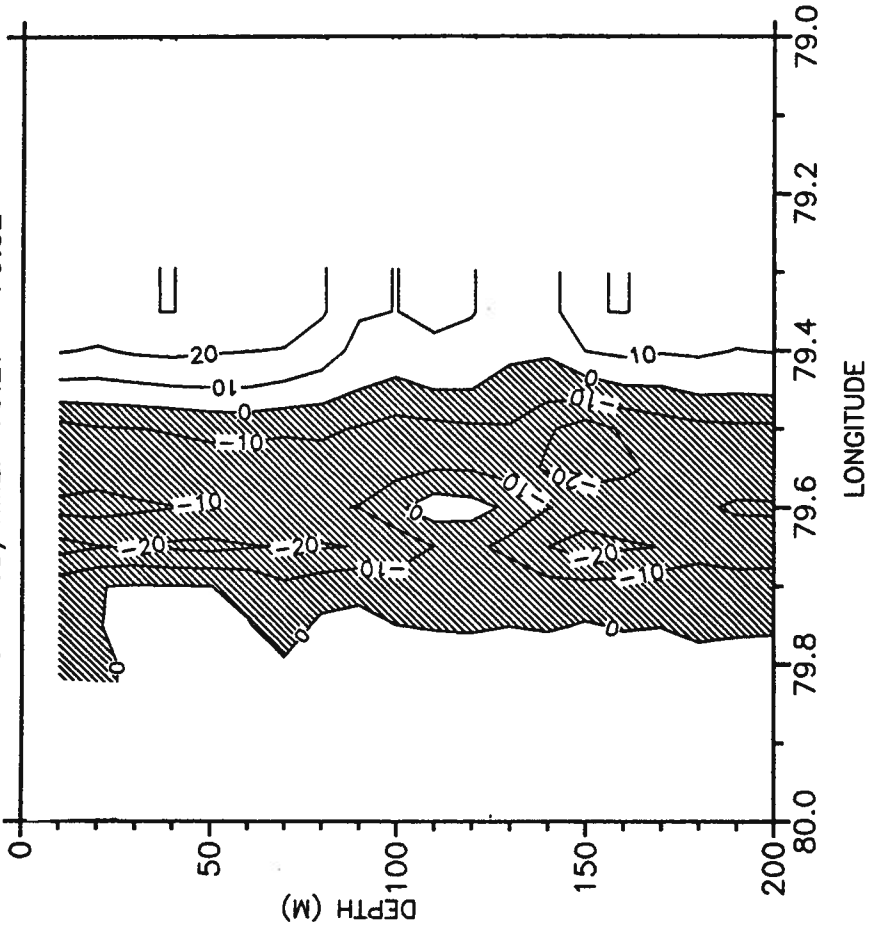

V-VELOCITY (LORAN C)  
MARCH 1984 JD/TIME: 79.27 - 79.82

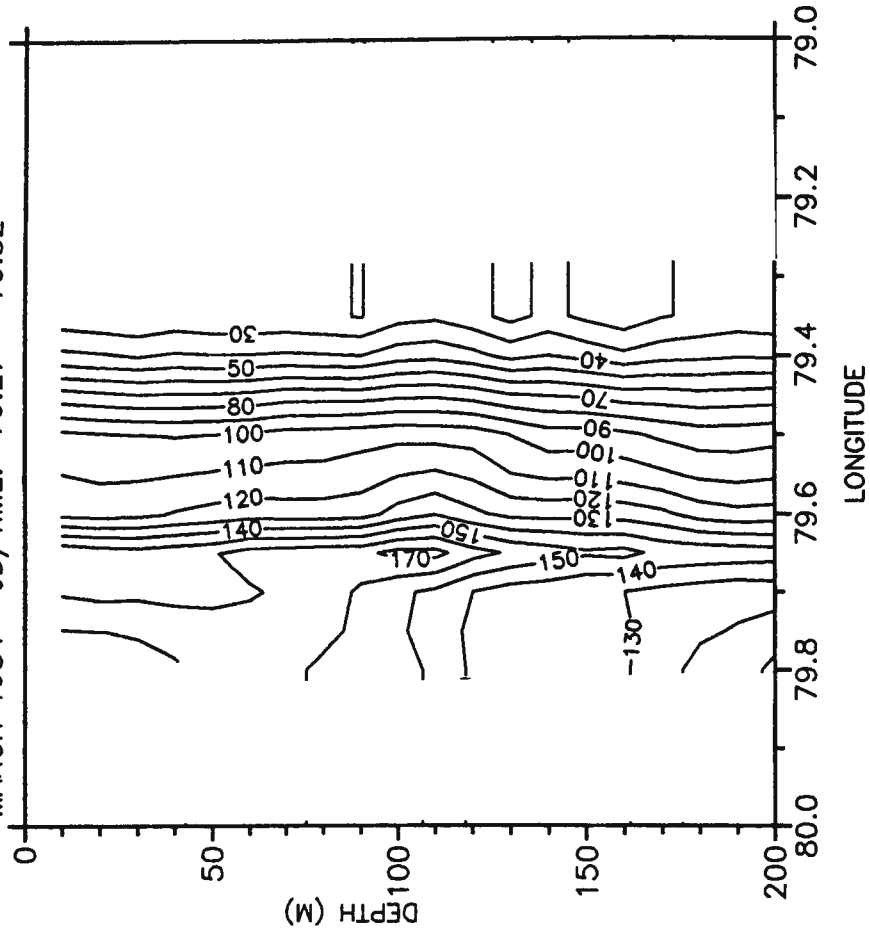

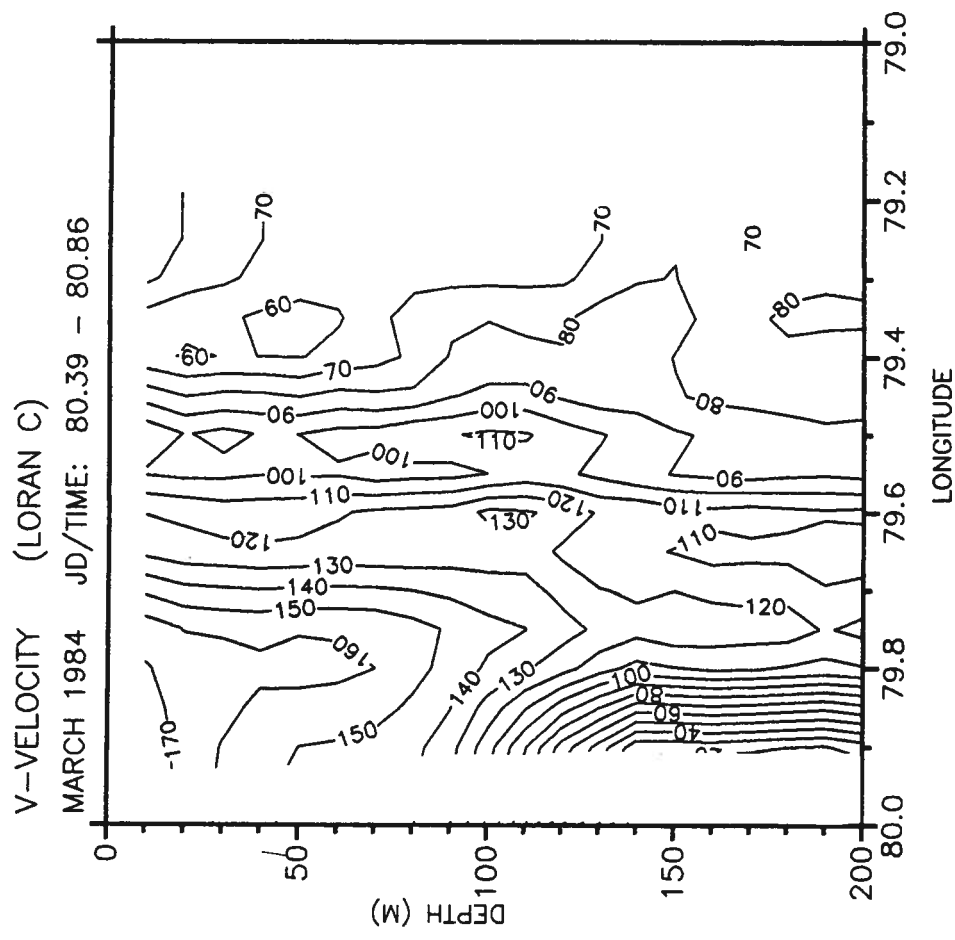
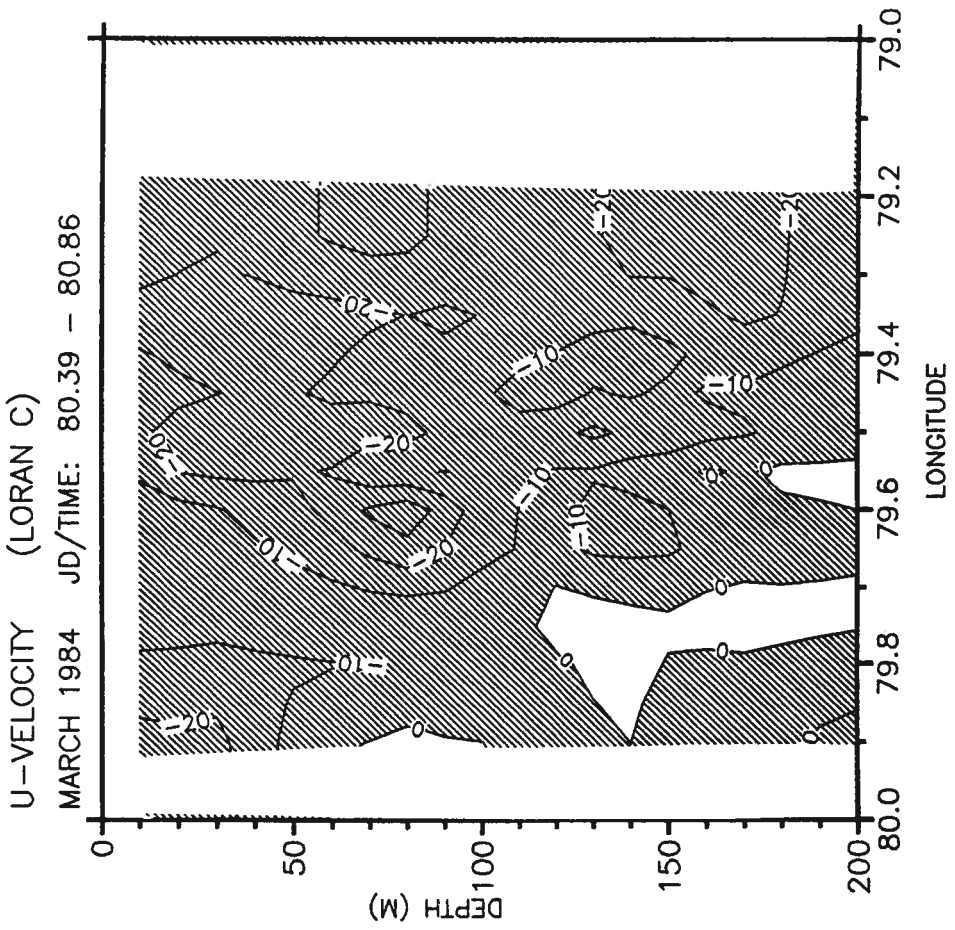

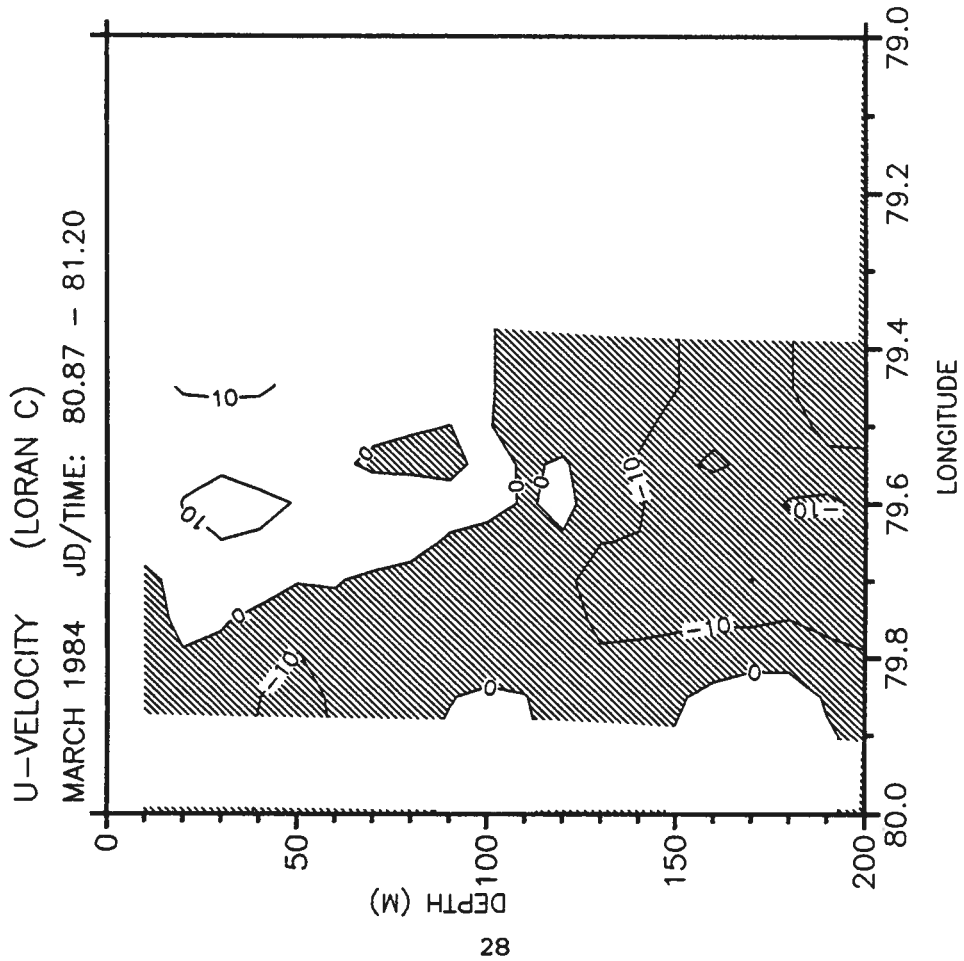
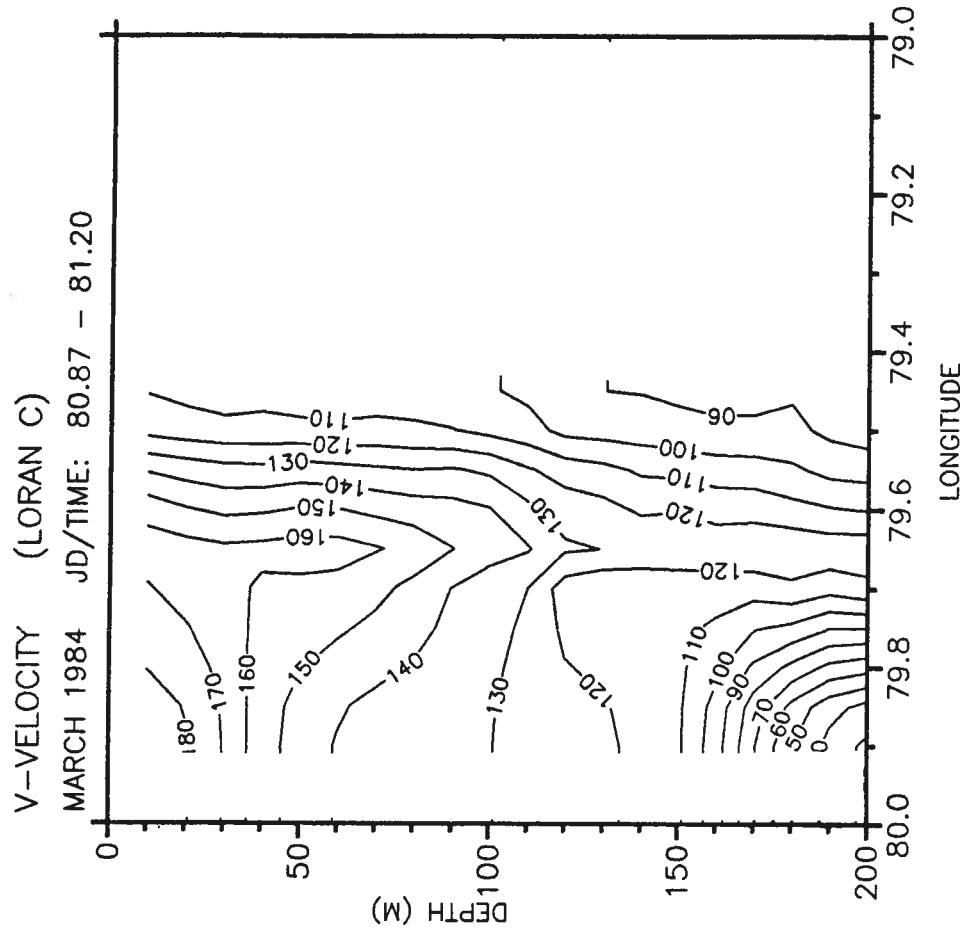

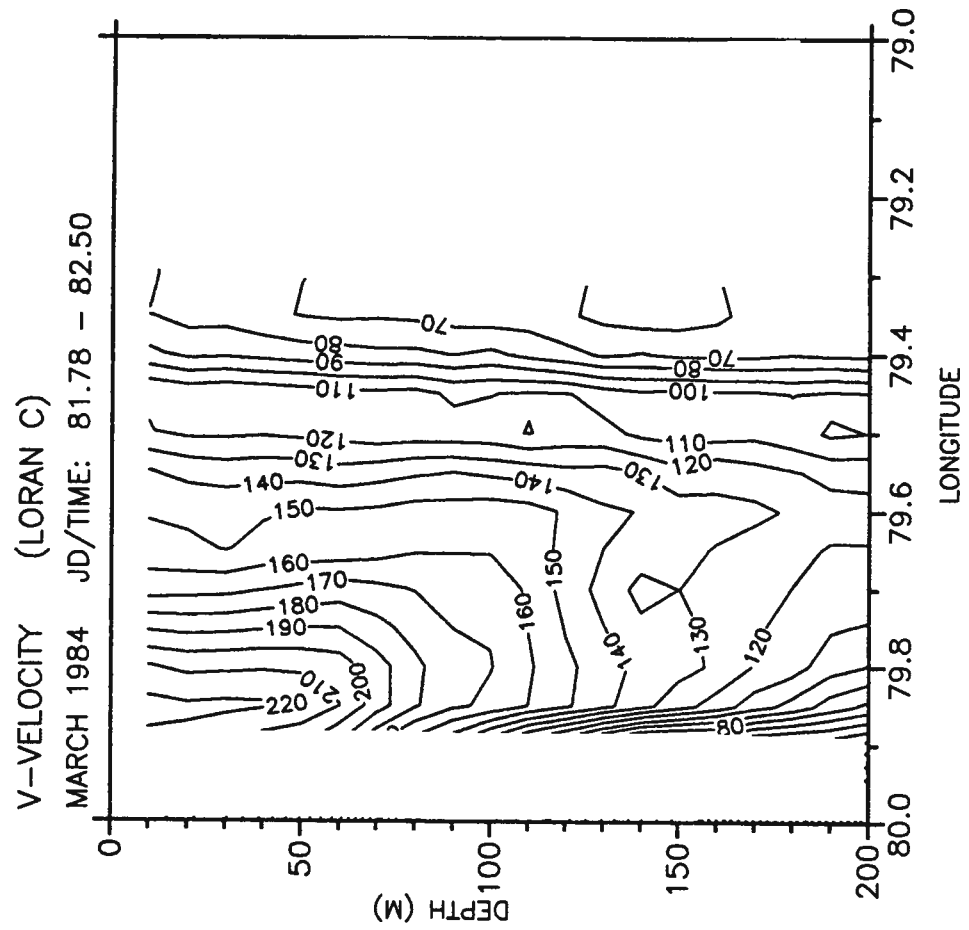
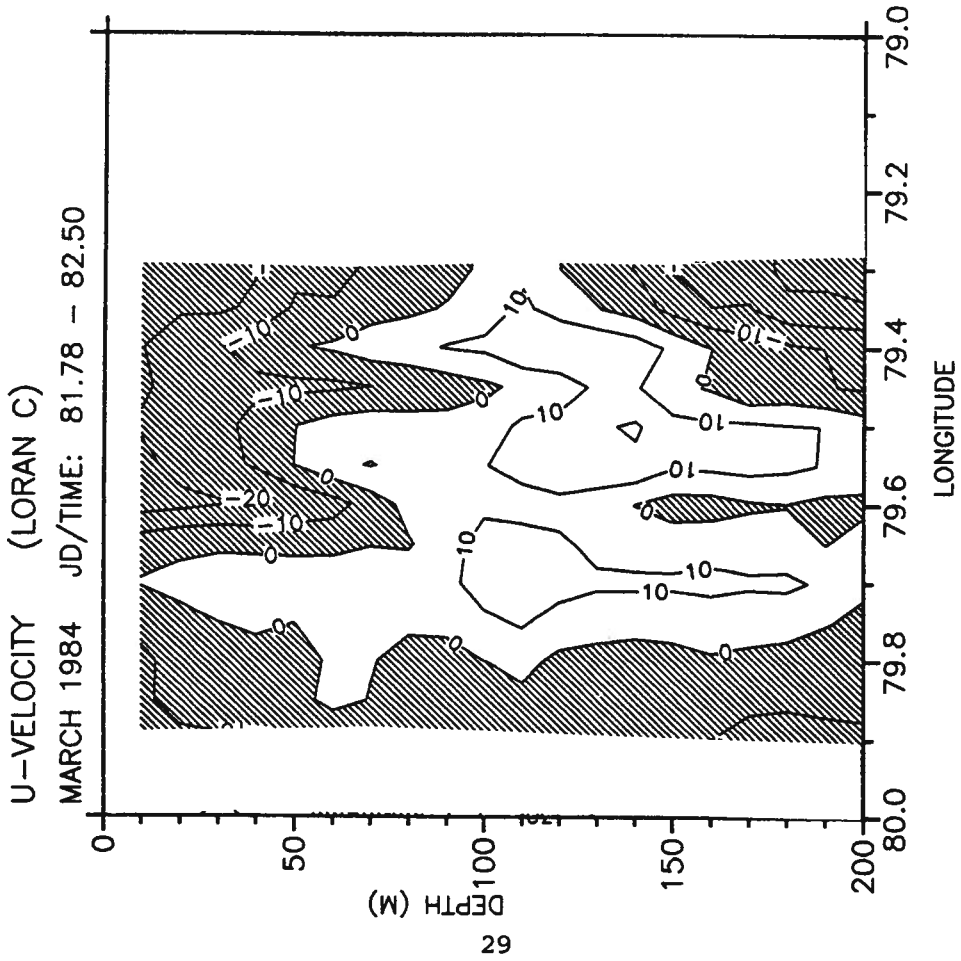



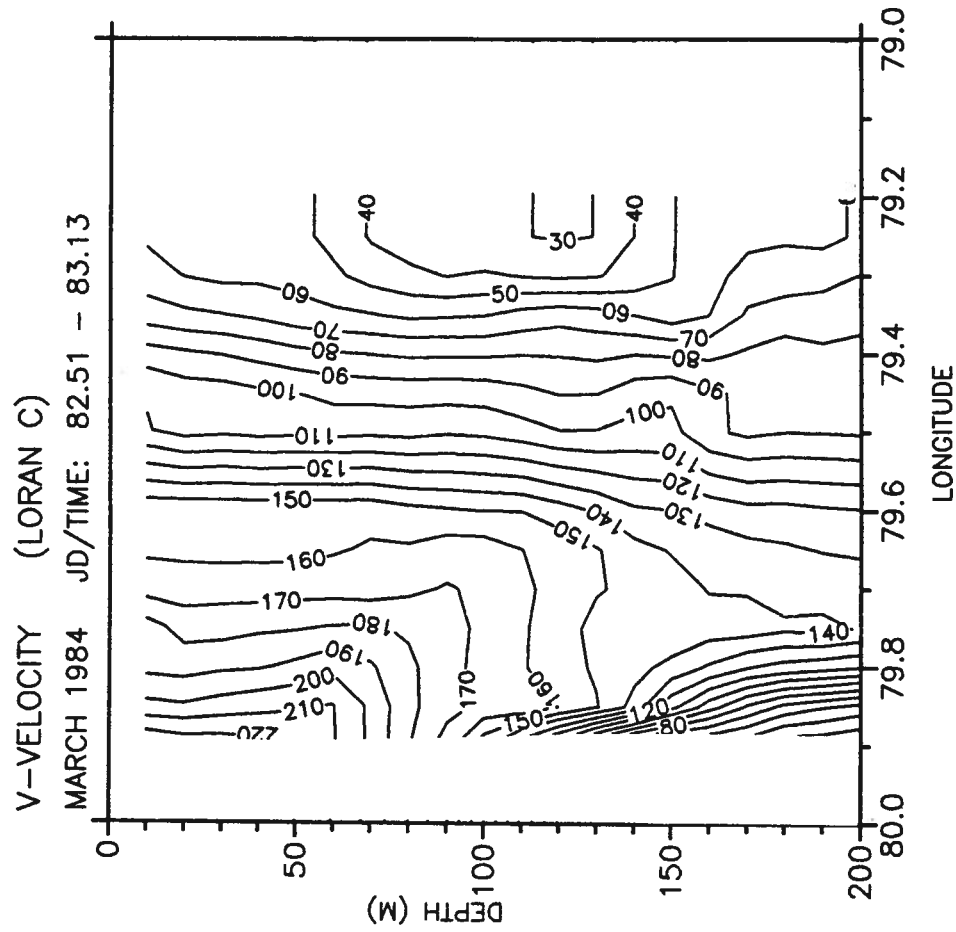
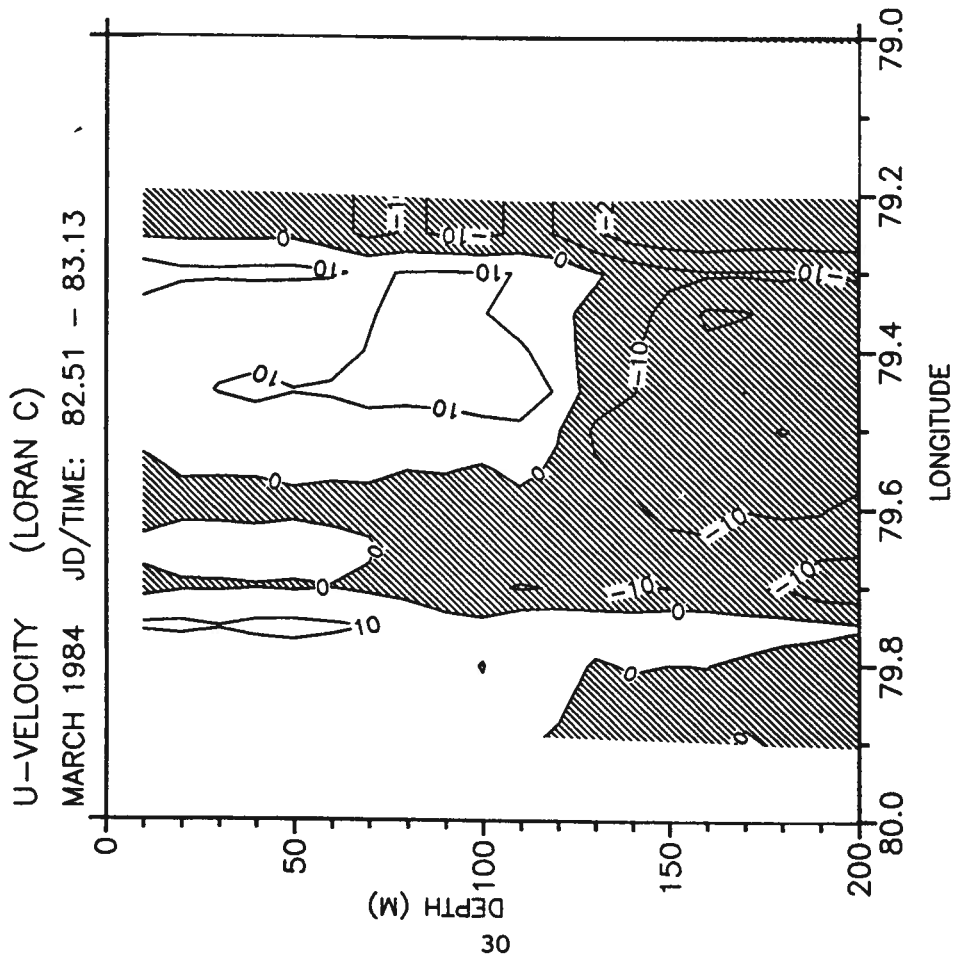

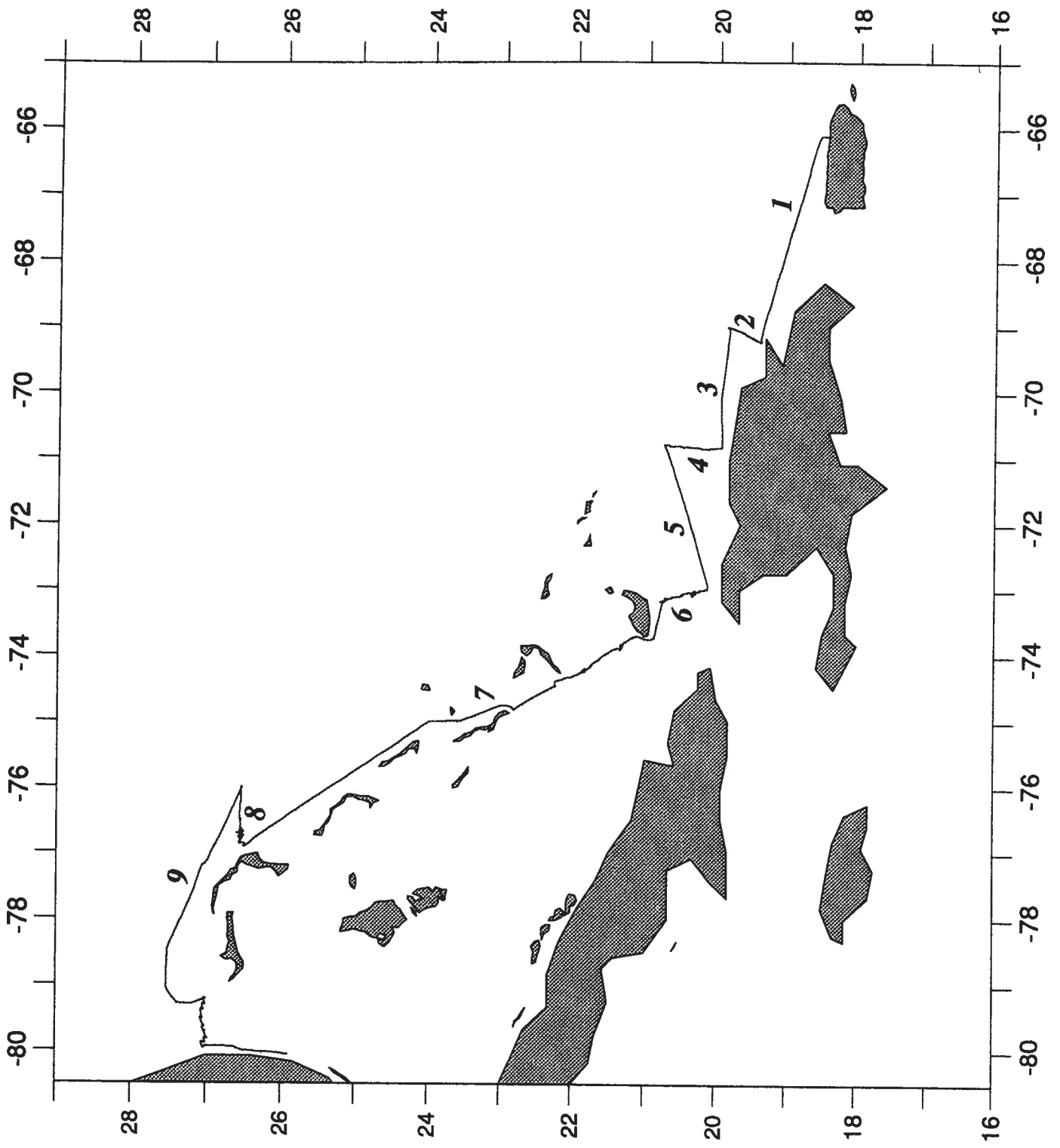

*Map of the Ametek-Straza (ADCP) trackline - August 1984*

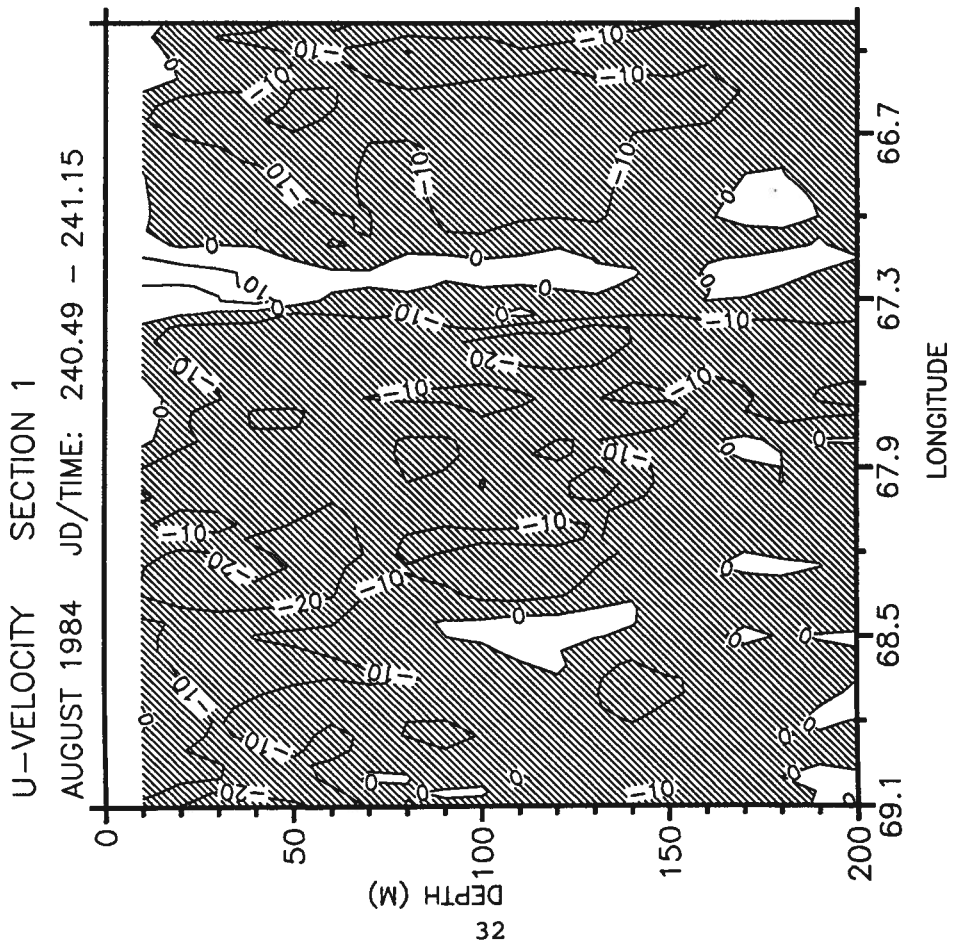
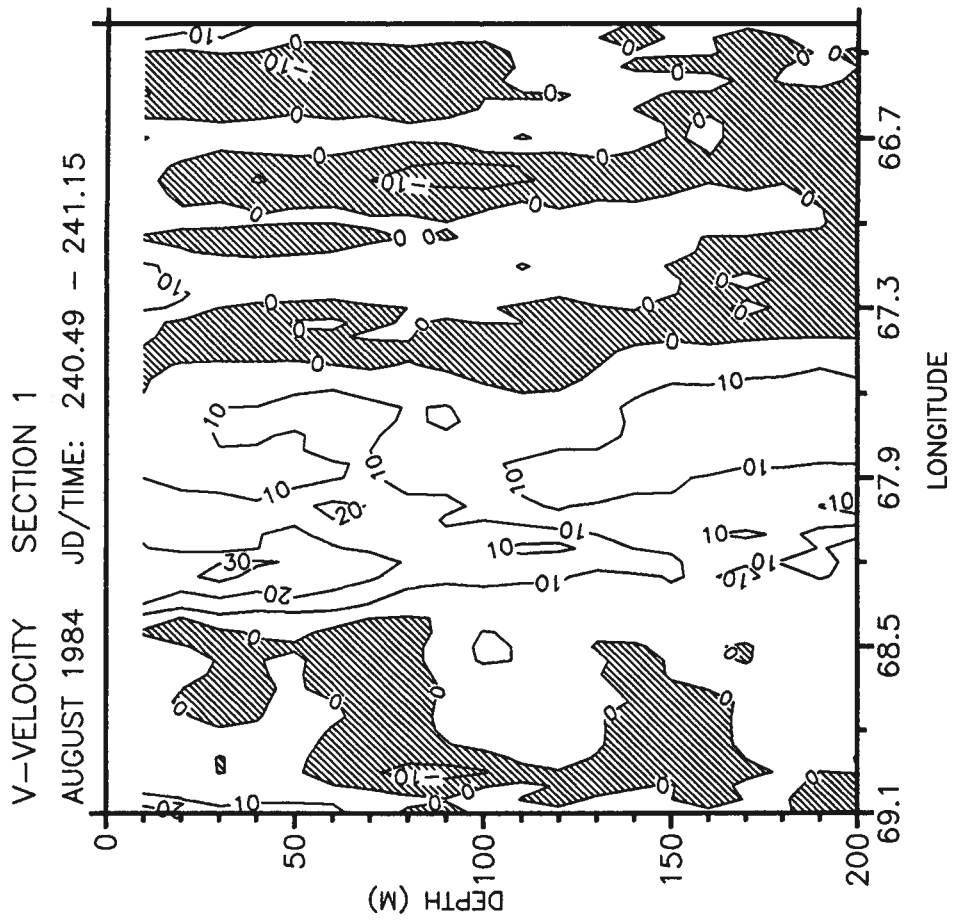

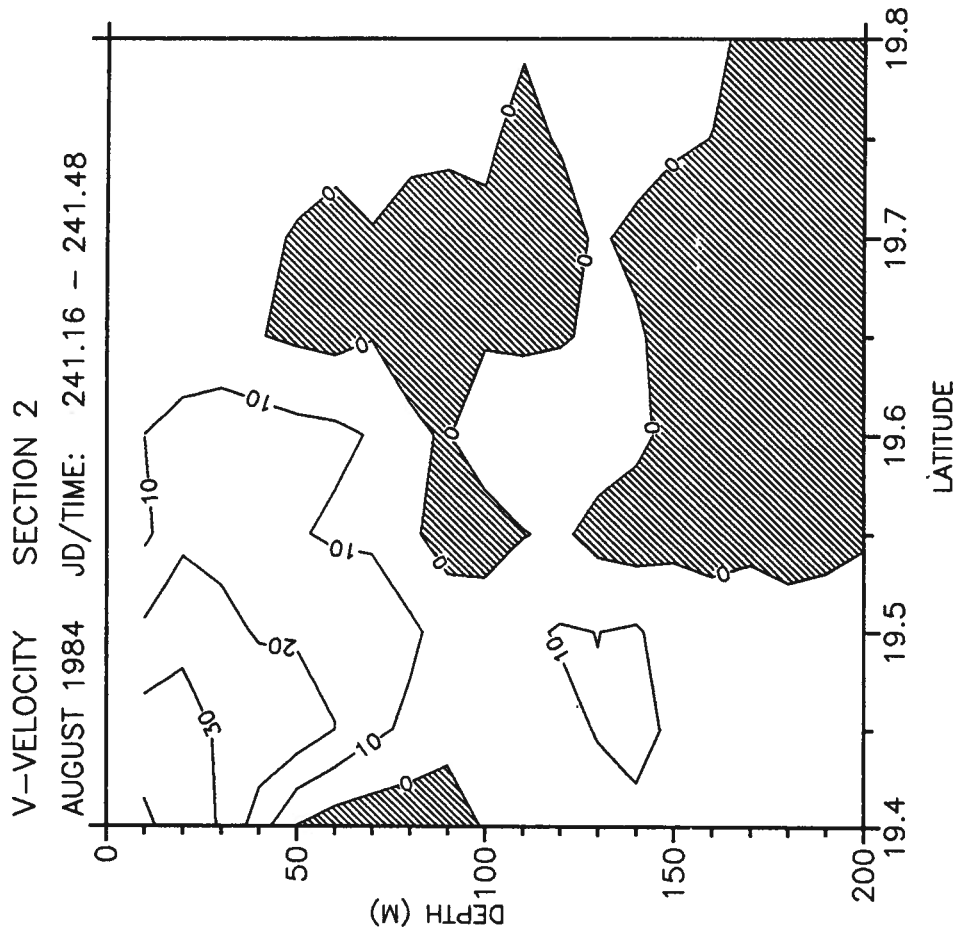
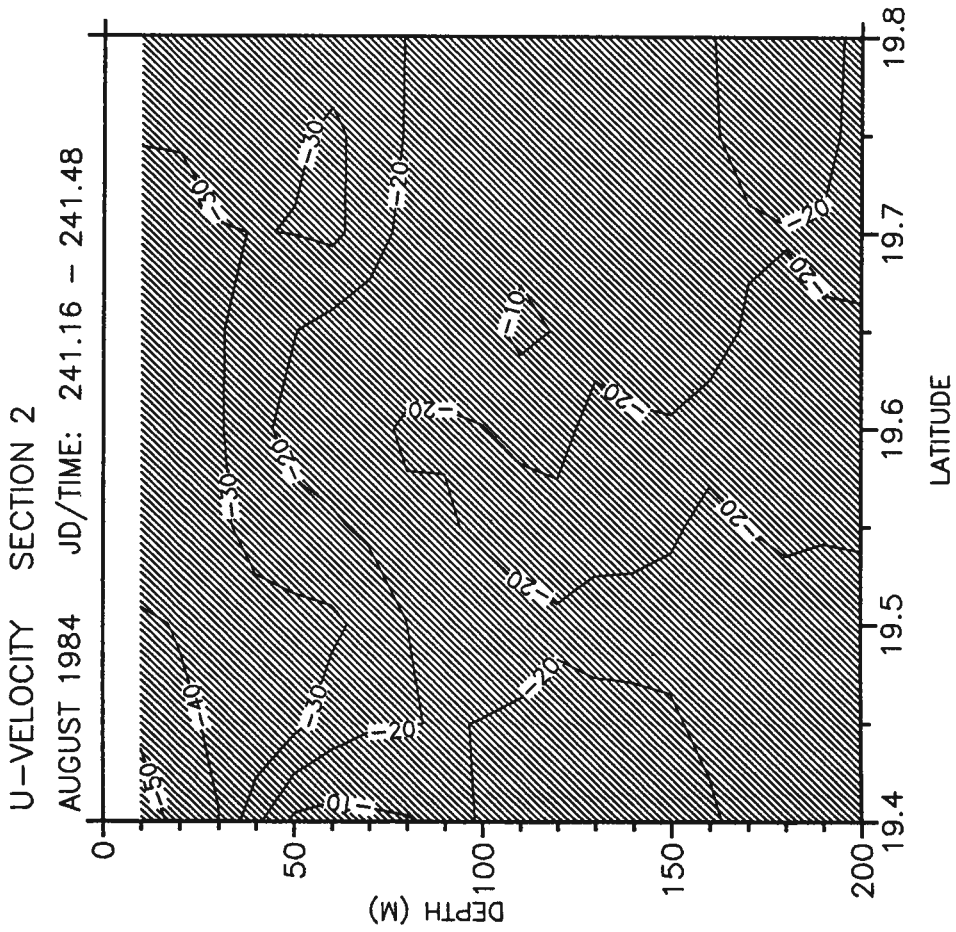

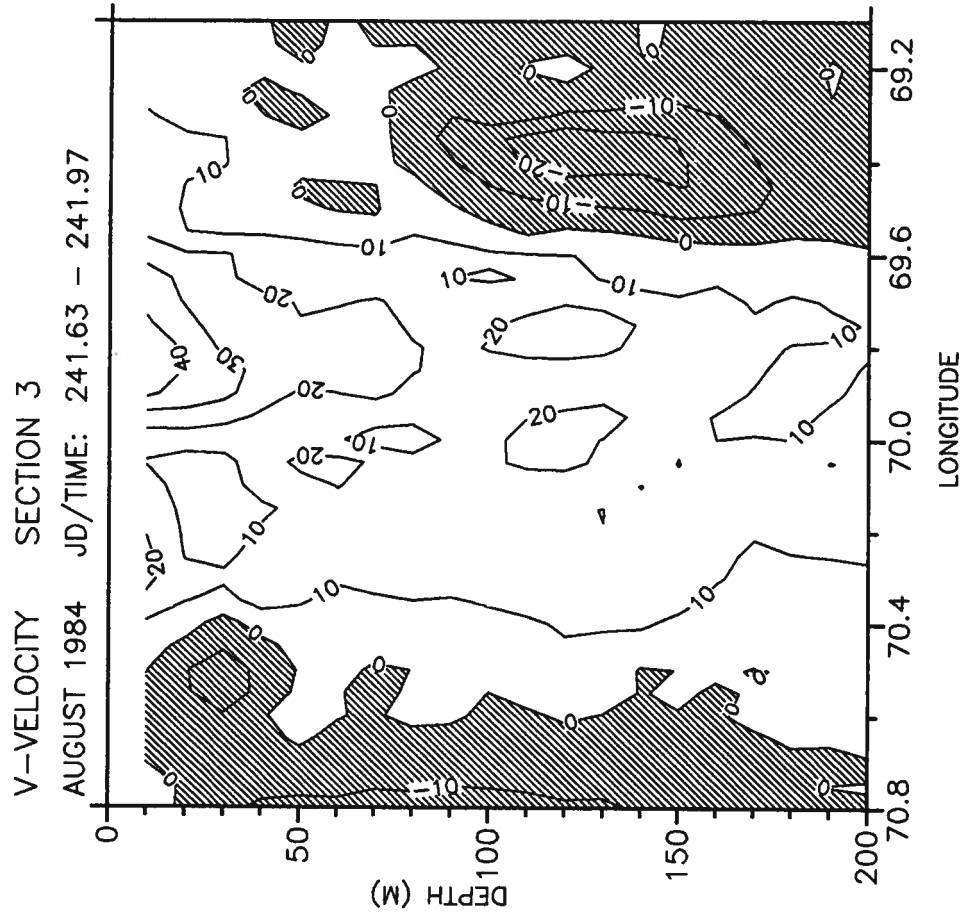
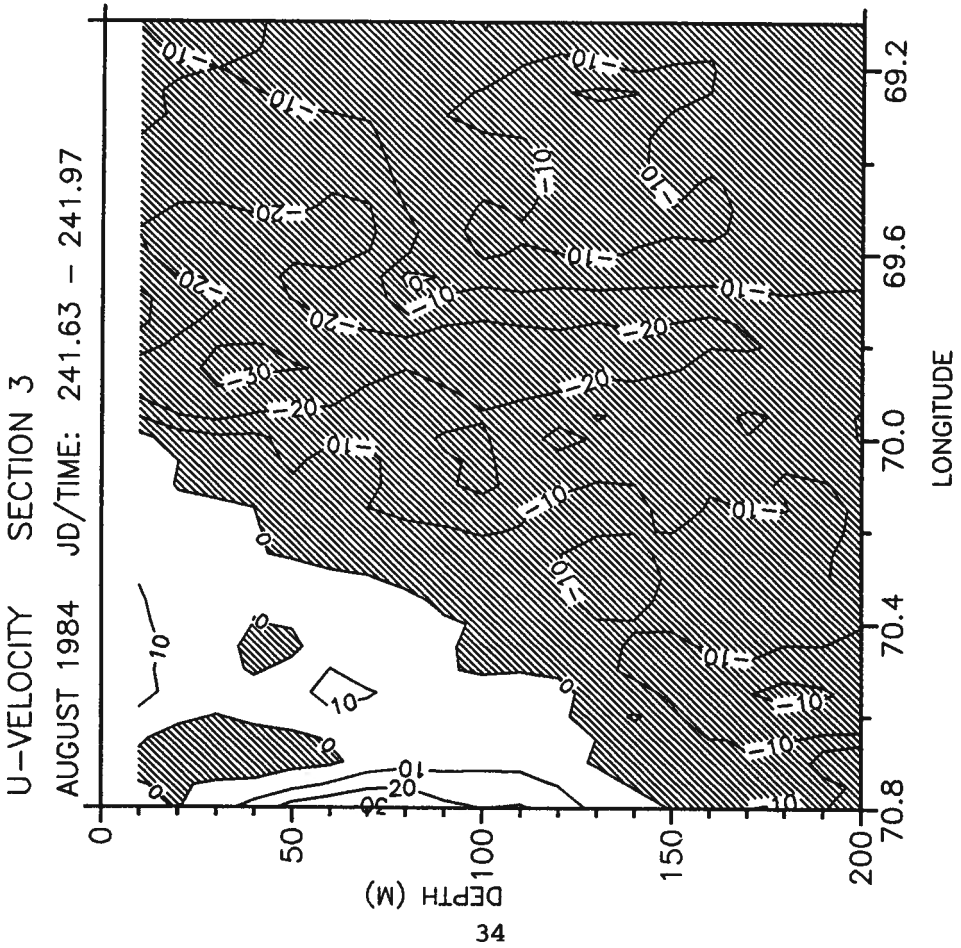

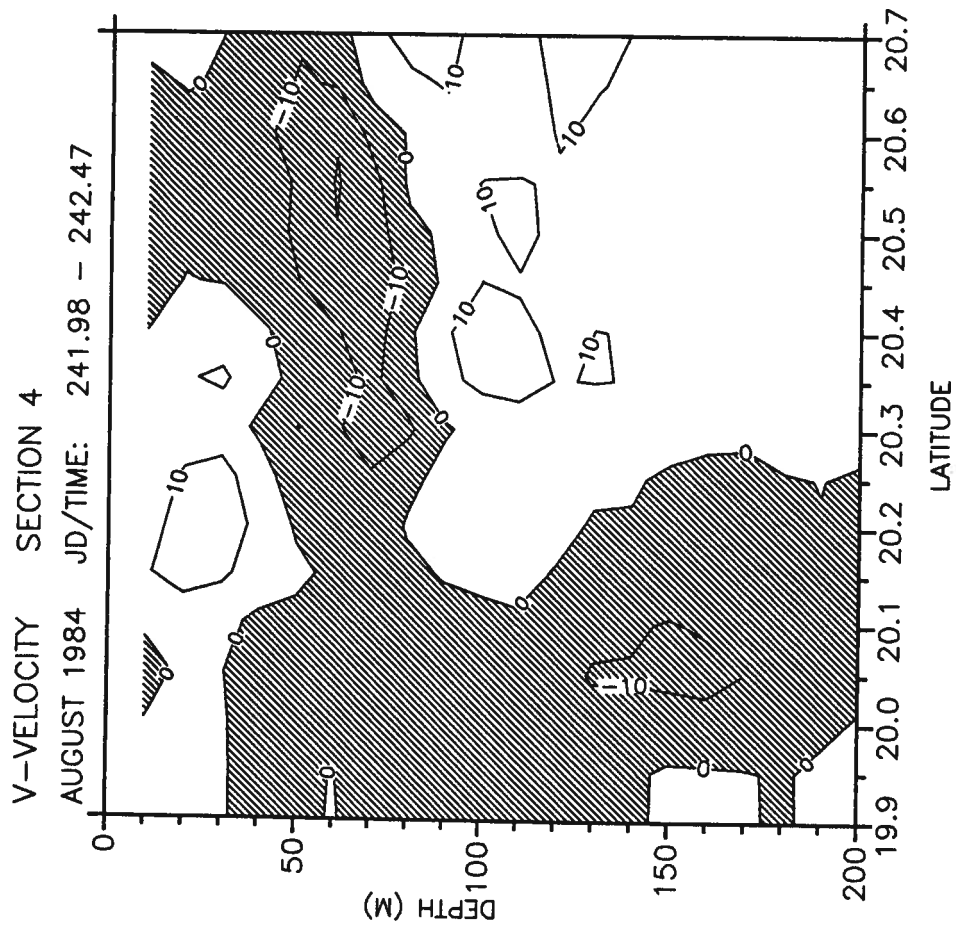
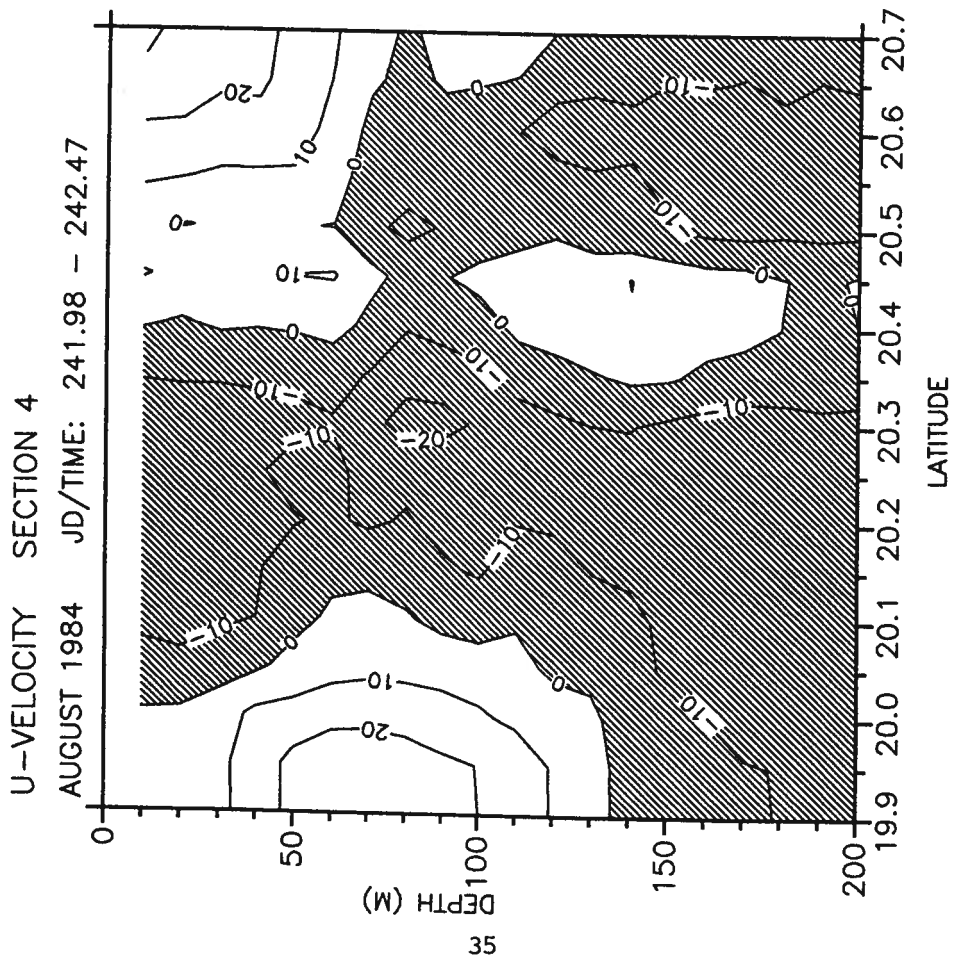

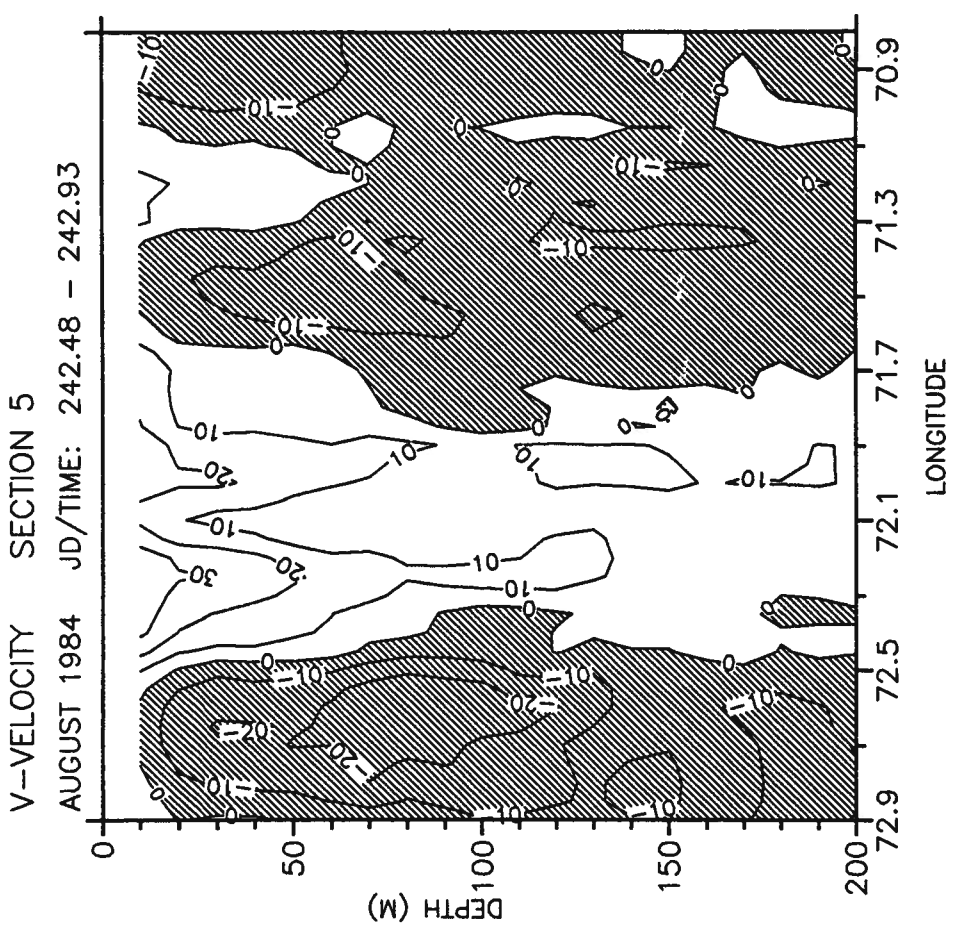
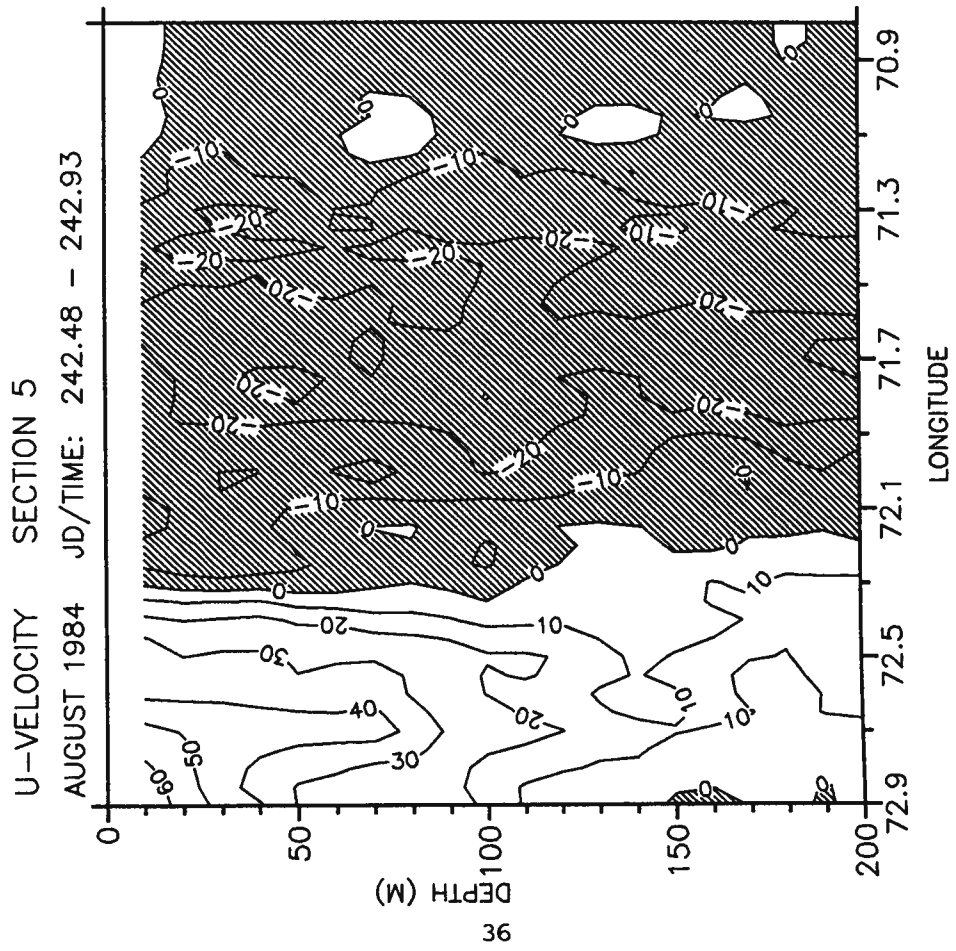

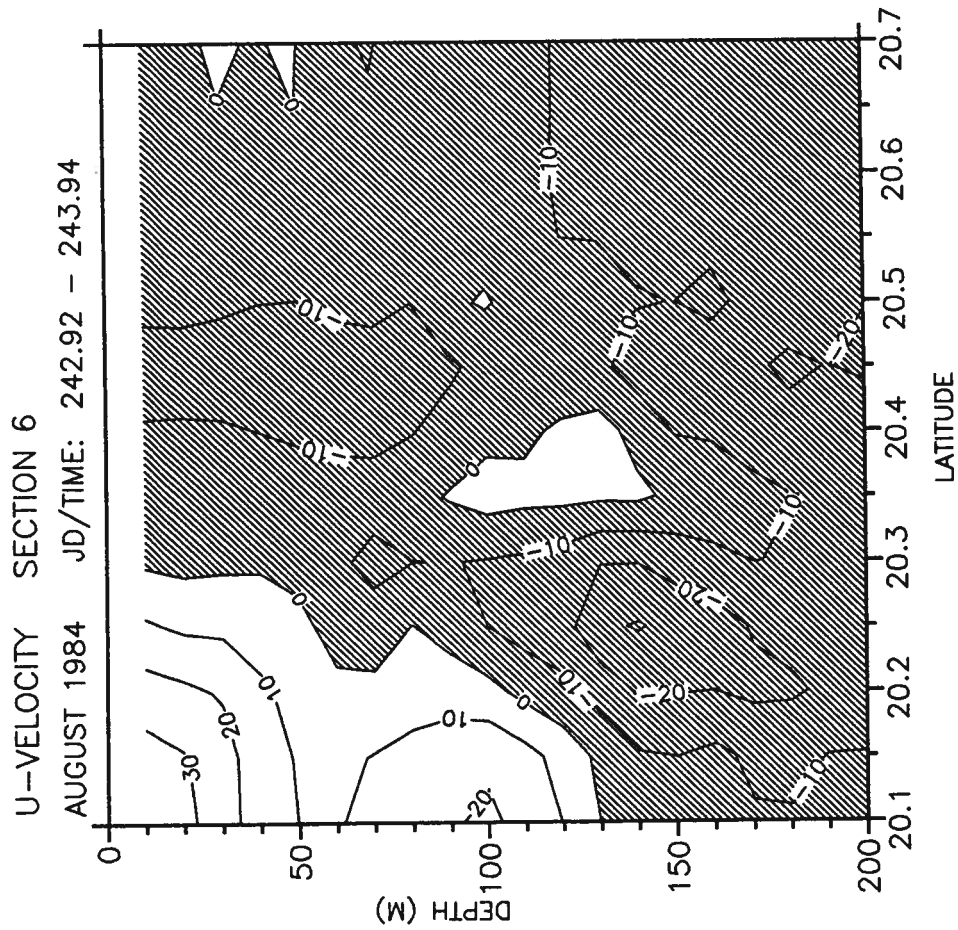
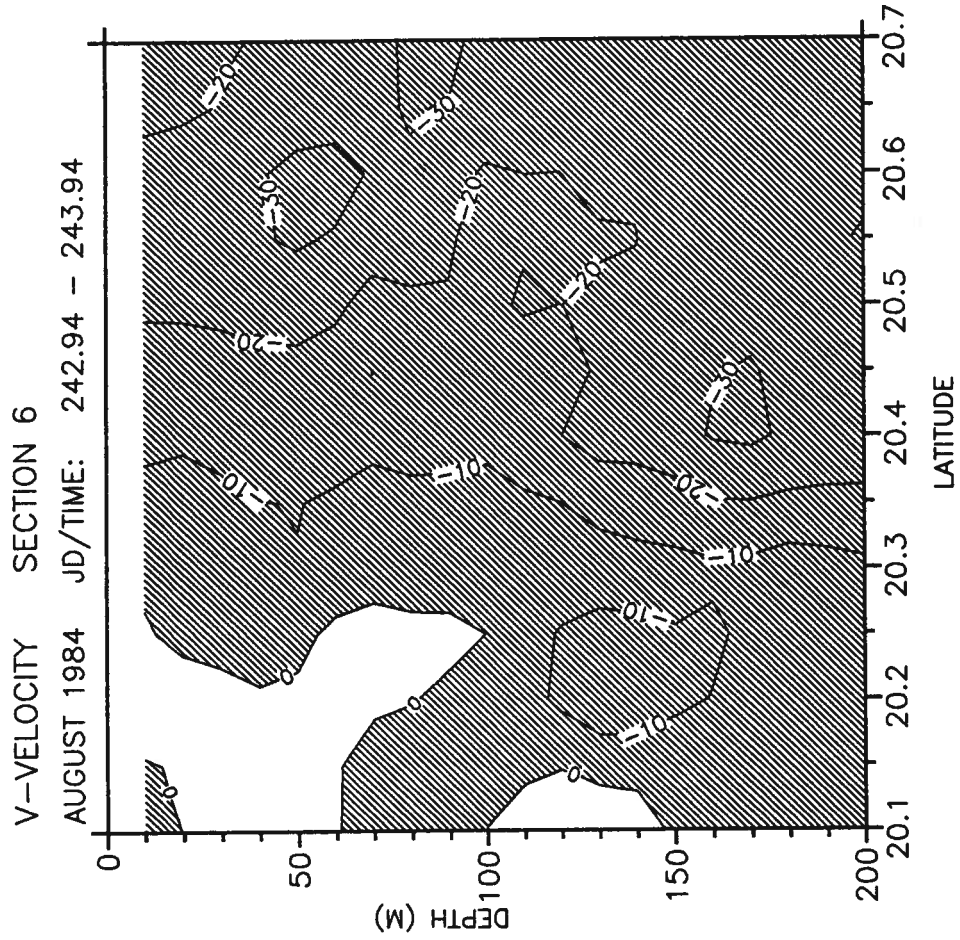



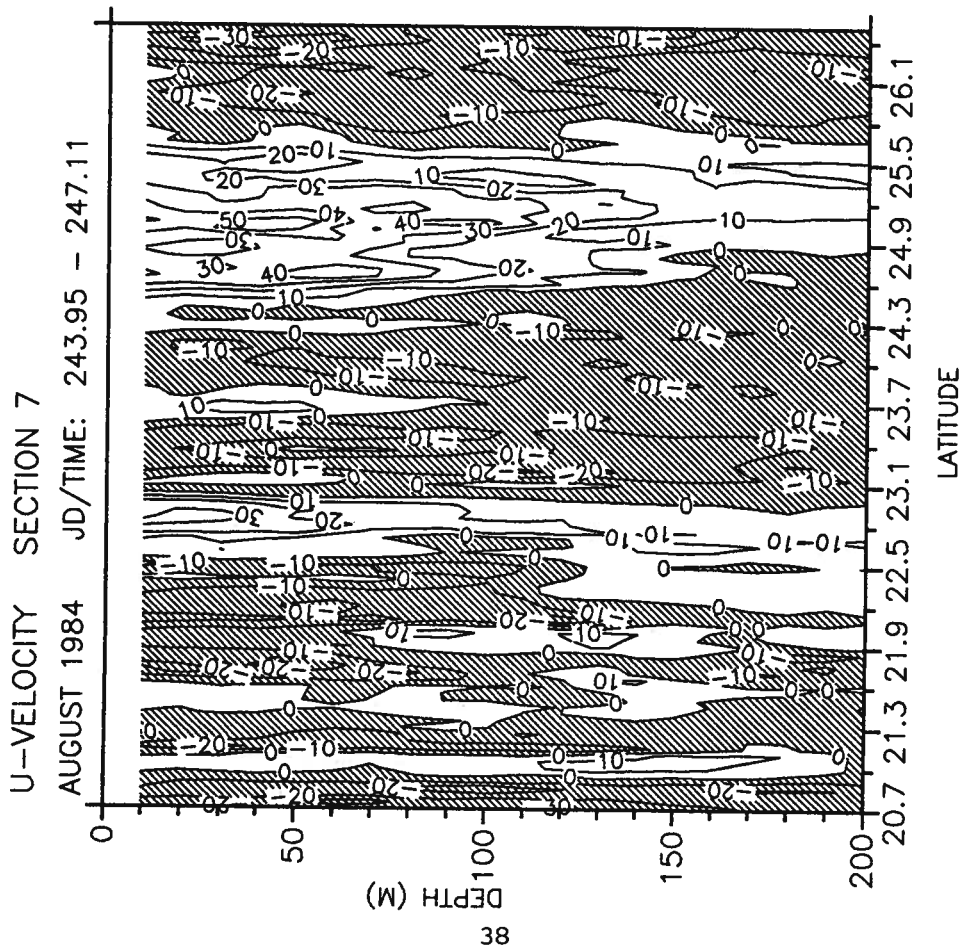
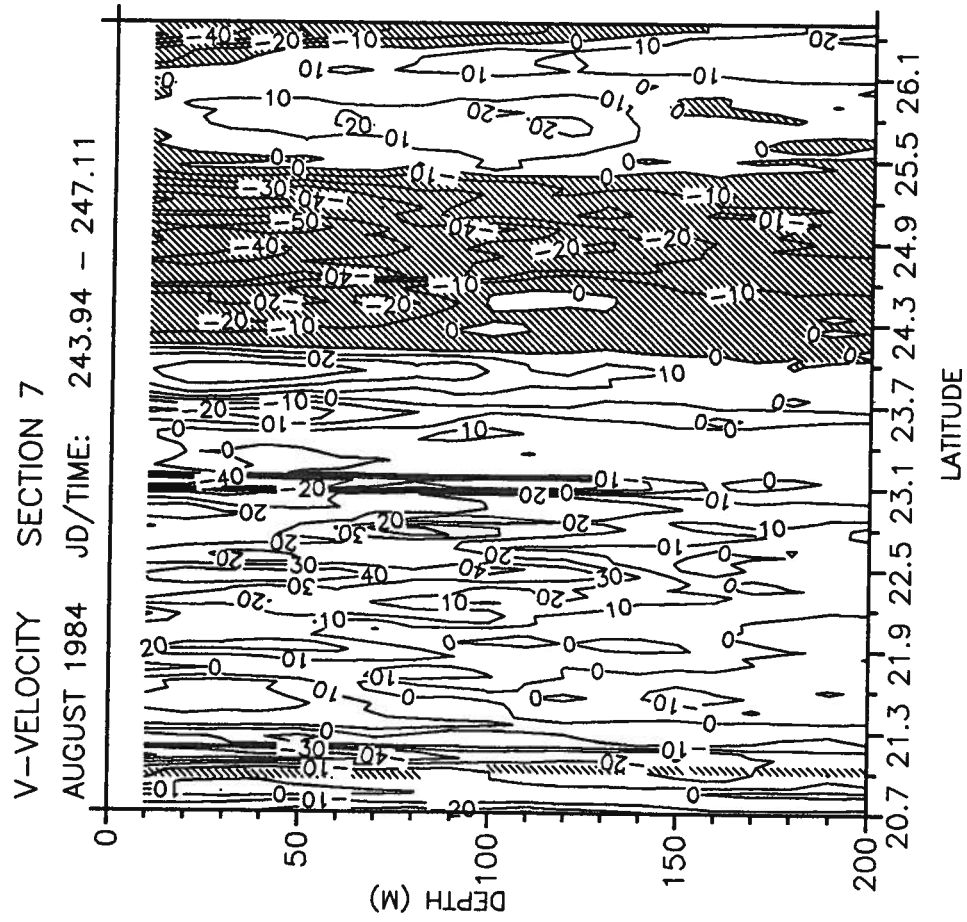

U-VELOCITY SECTION 8 (LORAN C)

AUGUST 1984 JD/TIME: 247.12 - 248.21

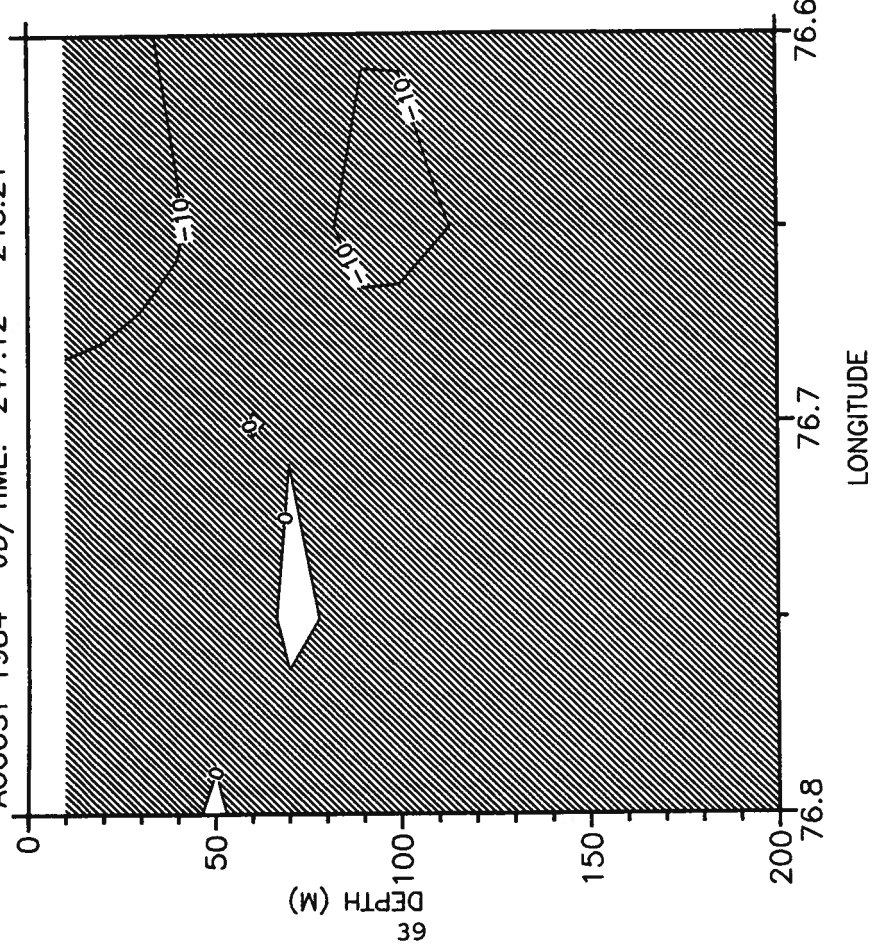

V-VELOCITY SECTION 8 (LORAN C)

DECEMBER 1983 JD/TIME: 247.21 - 248.21

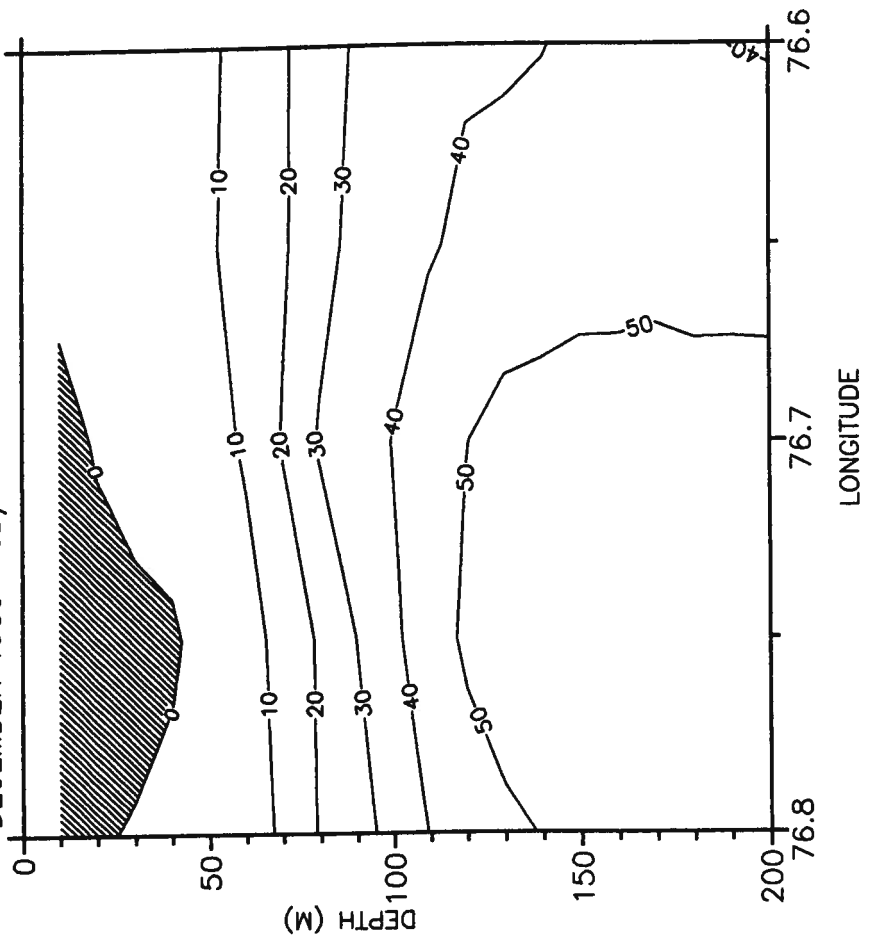

U-VELOCITY SECTION 8 (LORAN C)  
AUGUST 1984 JD/TIME: 248.37 - 249.04

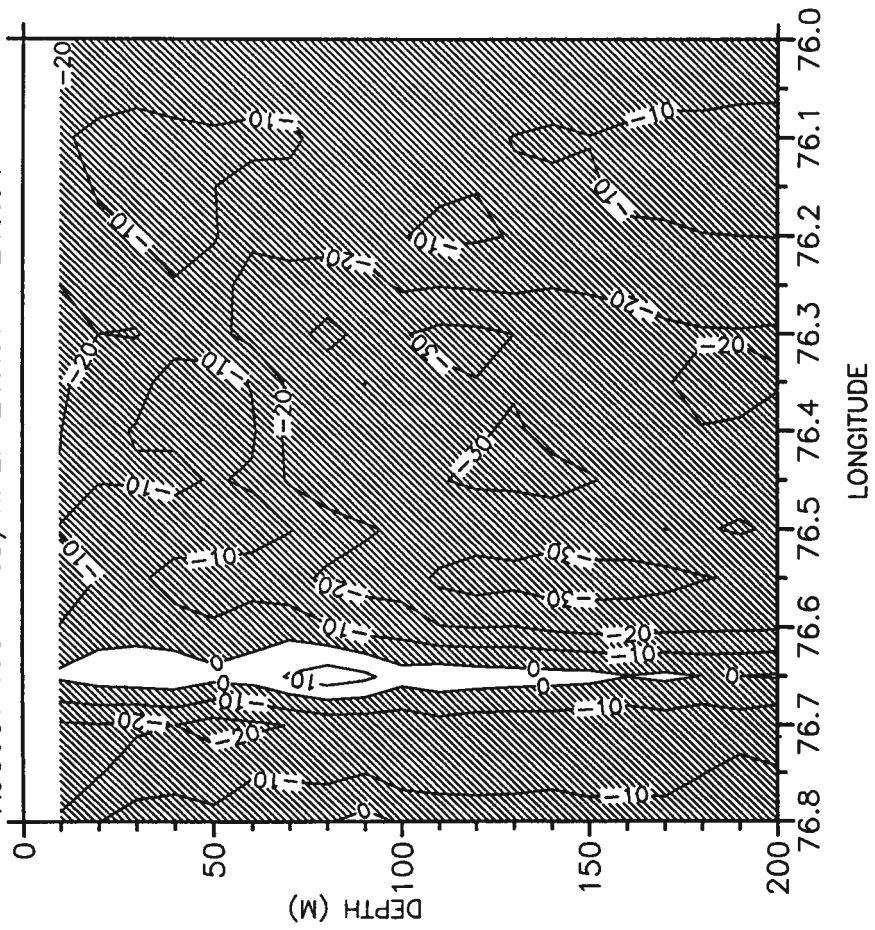

V-VELOCITY SECTION 8 (LORAN C)  
AUGUST 1984 JD/TIME: 248.37 - 249.04

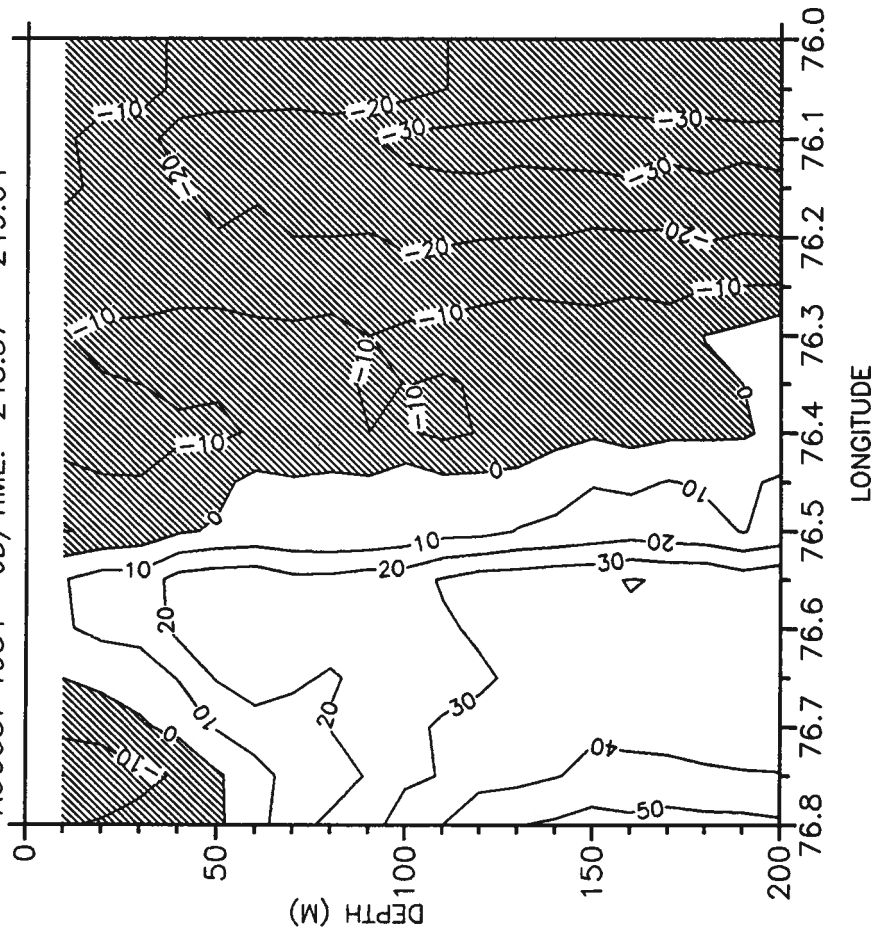

U-VELOCITY SECTION 9 (LORAN C)  
AUGUST 1984 JD/TIME: 249.08 - 249.67

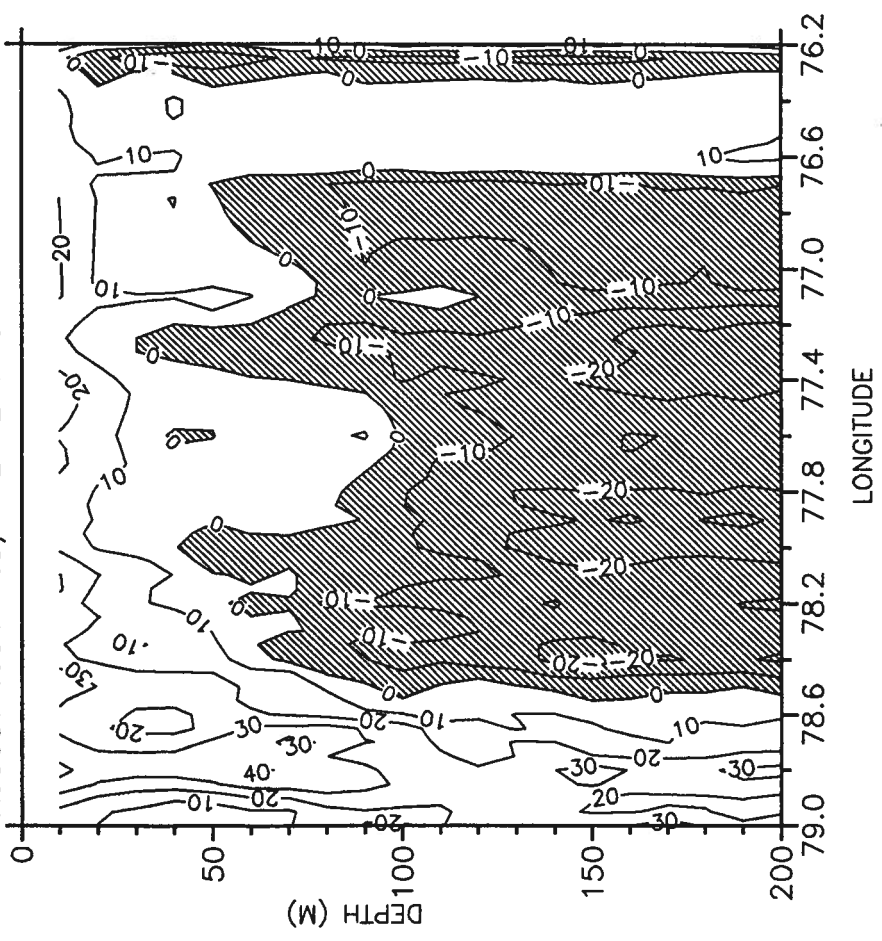

V-VELOCITY SECTION 9 (LORAN C)  
AUGUST 1984 JD/TIME: 249.08 - 249.67

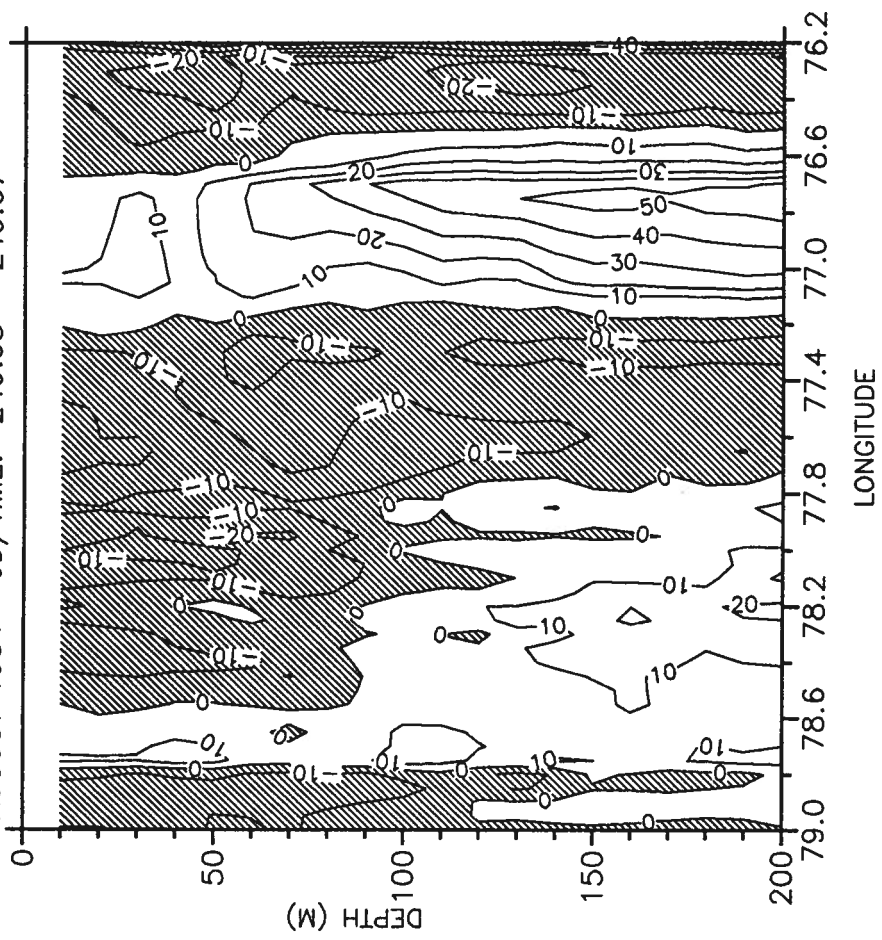

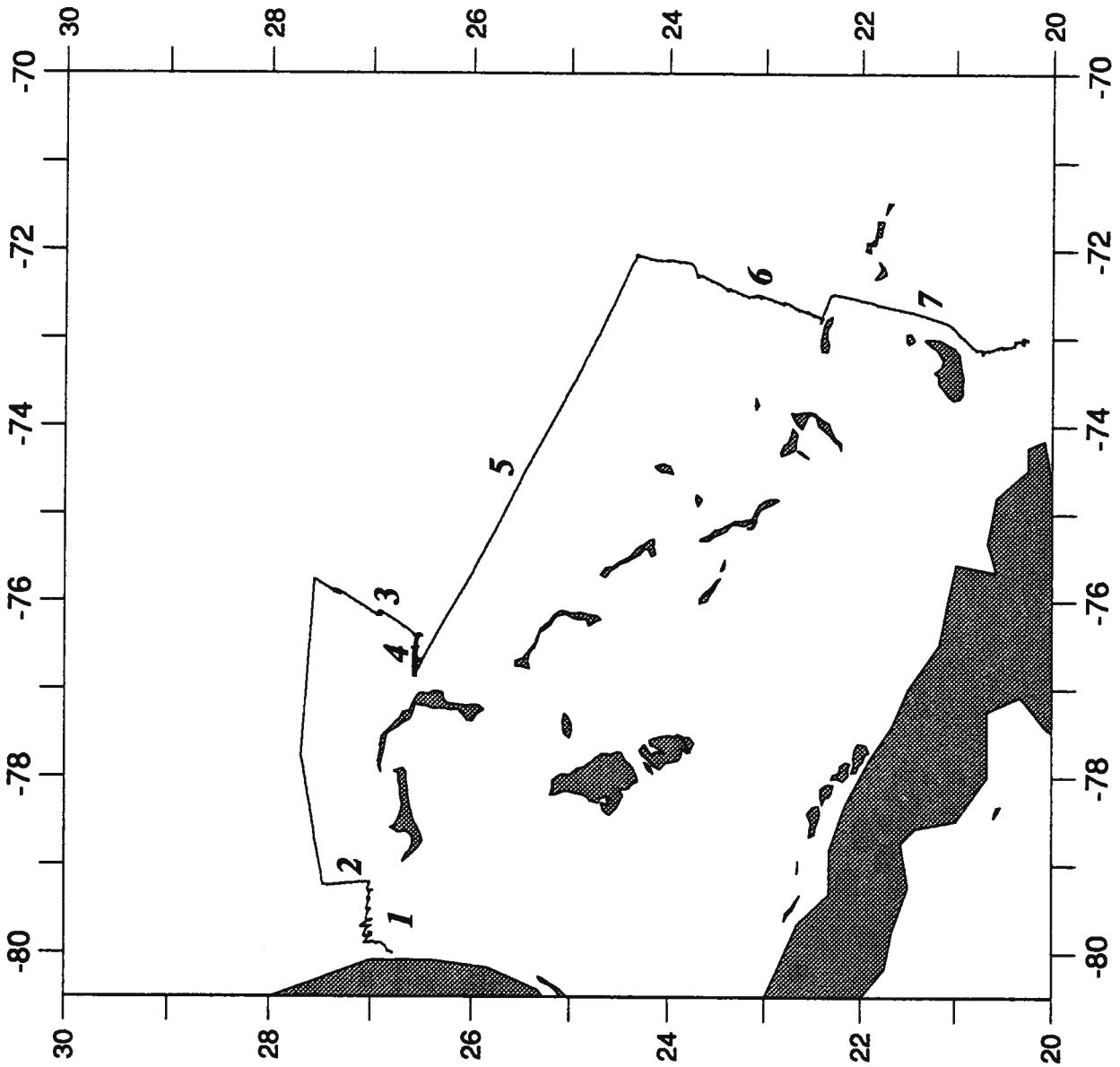

*Map of the Ametek-Straza (ADCP) trackline - April 1985*

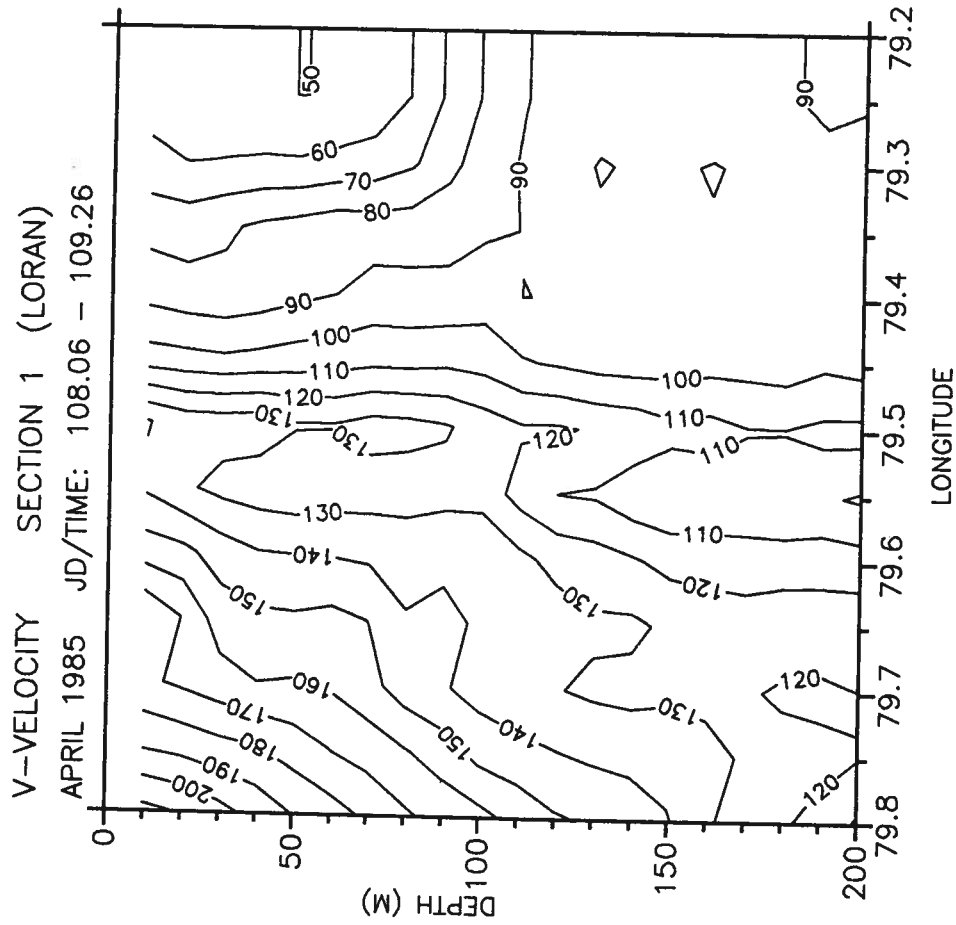
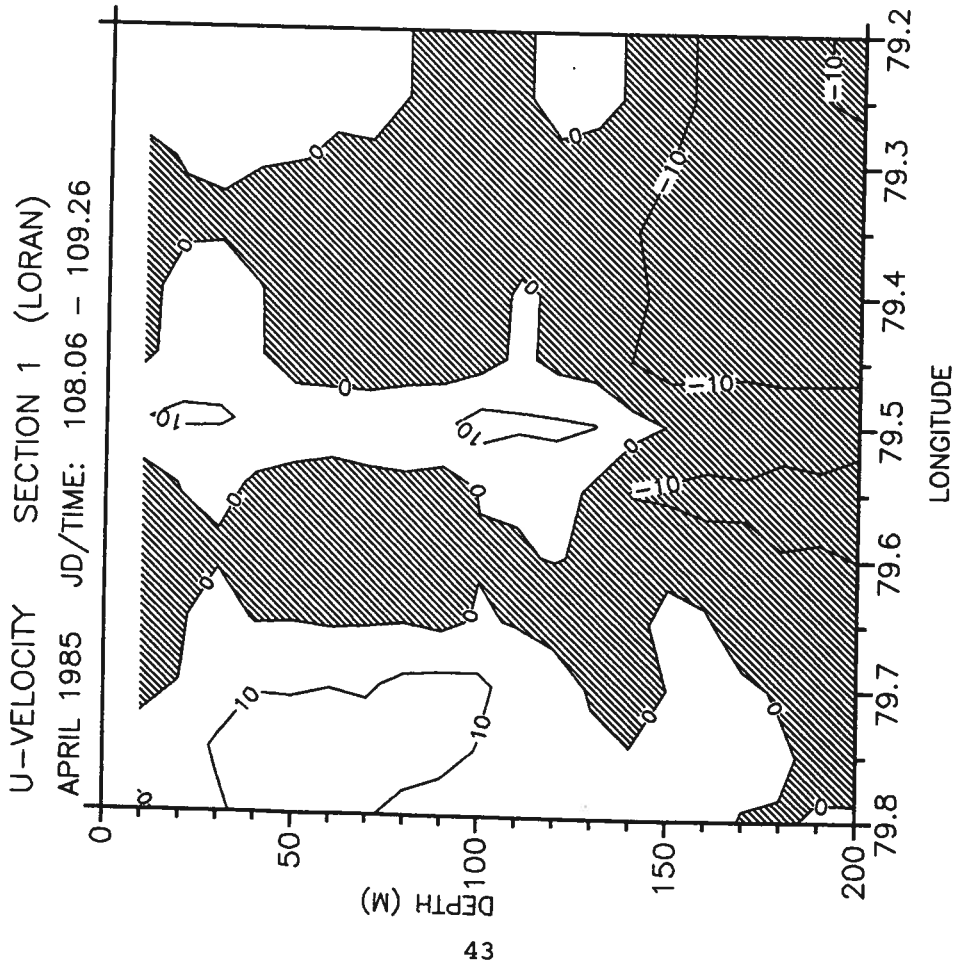

U-VELOCITY SECTION 2 (LORAN C)  
 APRIL 1985 JD/TIME: 109.27 - 109.35

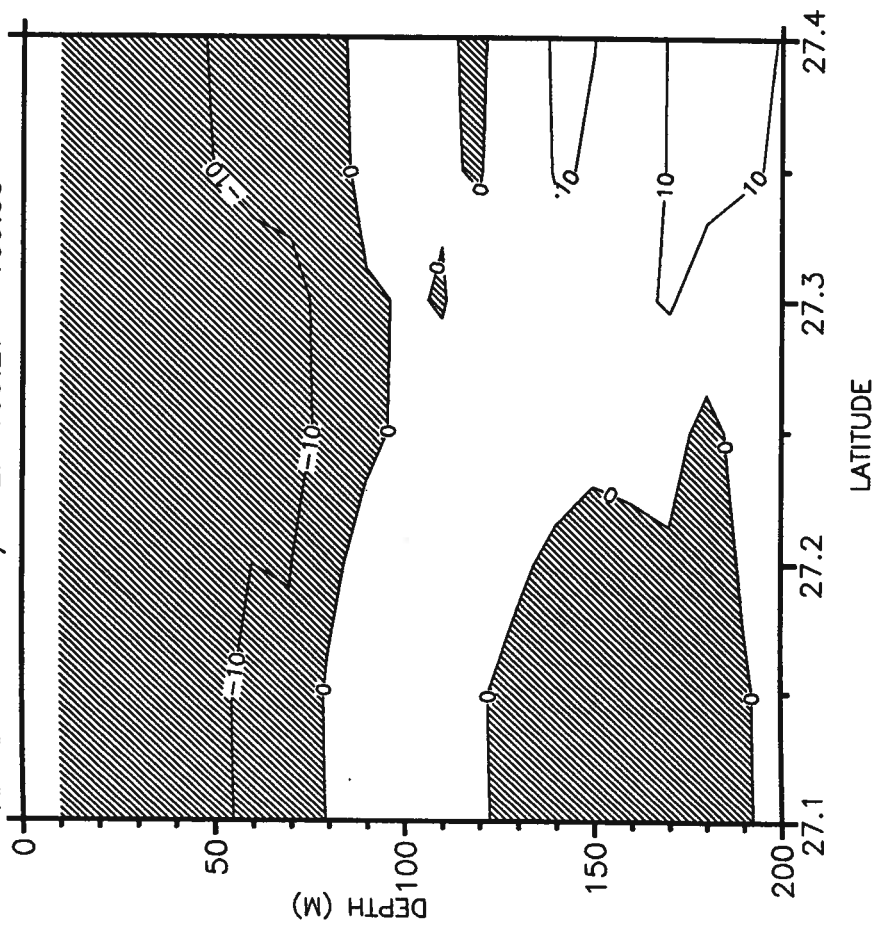

V-VELOCITY SECTION 2 (LORAN C)  
 APRIL 1985 JD/TIME: 109.27 - 109.35

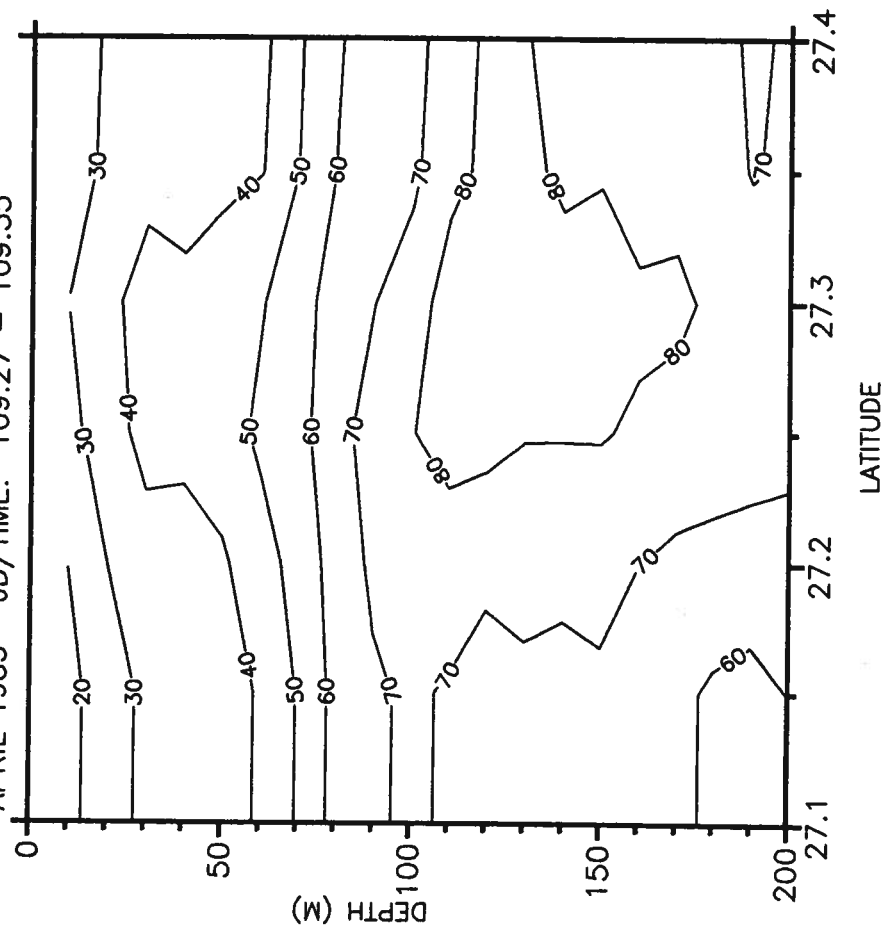

U-VELOCITY SECTION 3 (LORAN)

APRIL 1985 JD/TIME: 111.70 - 113.55

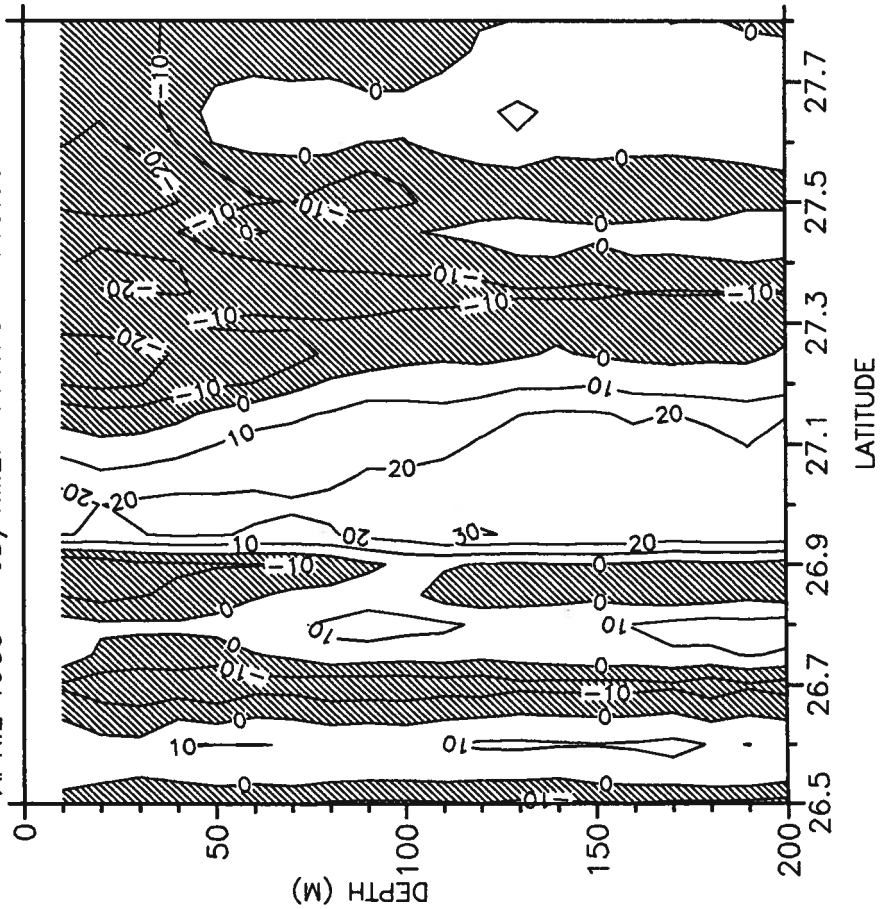

V-VELOCITY SECTION 3 (LORAN)

APRIL 1985 JD/TIME: 111.70 - 113.55

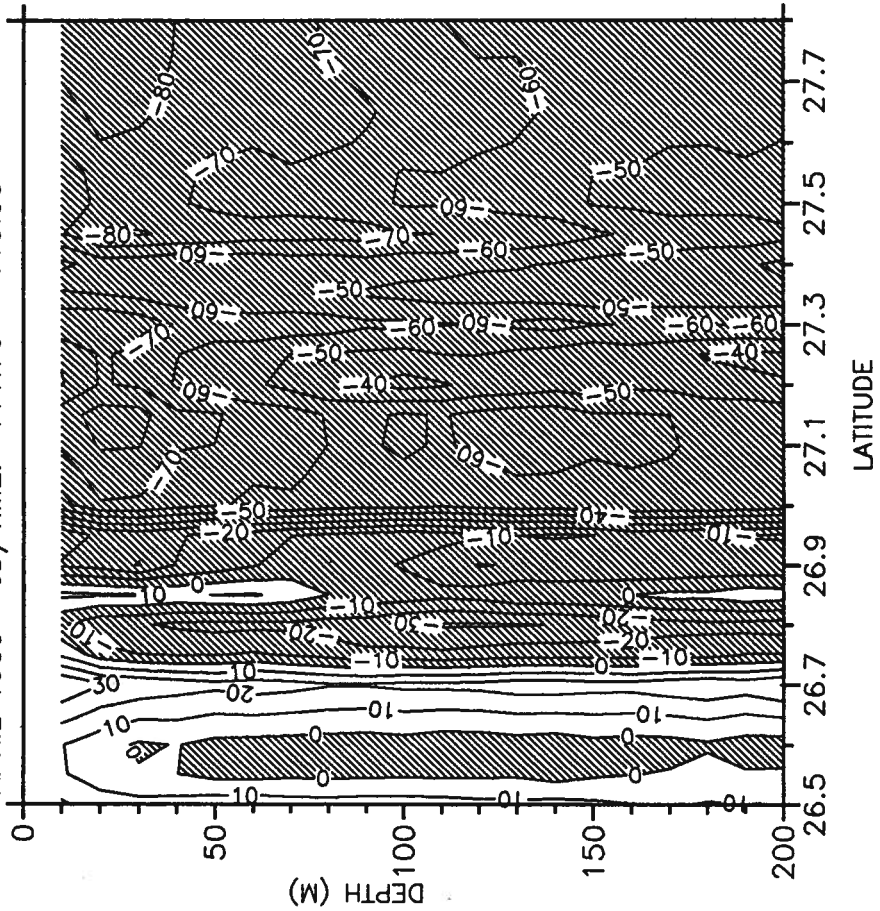



U-VELOCITY SECTION 4 (LORAN)

APRIL 1985 JD/TIME: 113.56 - 115.01

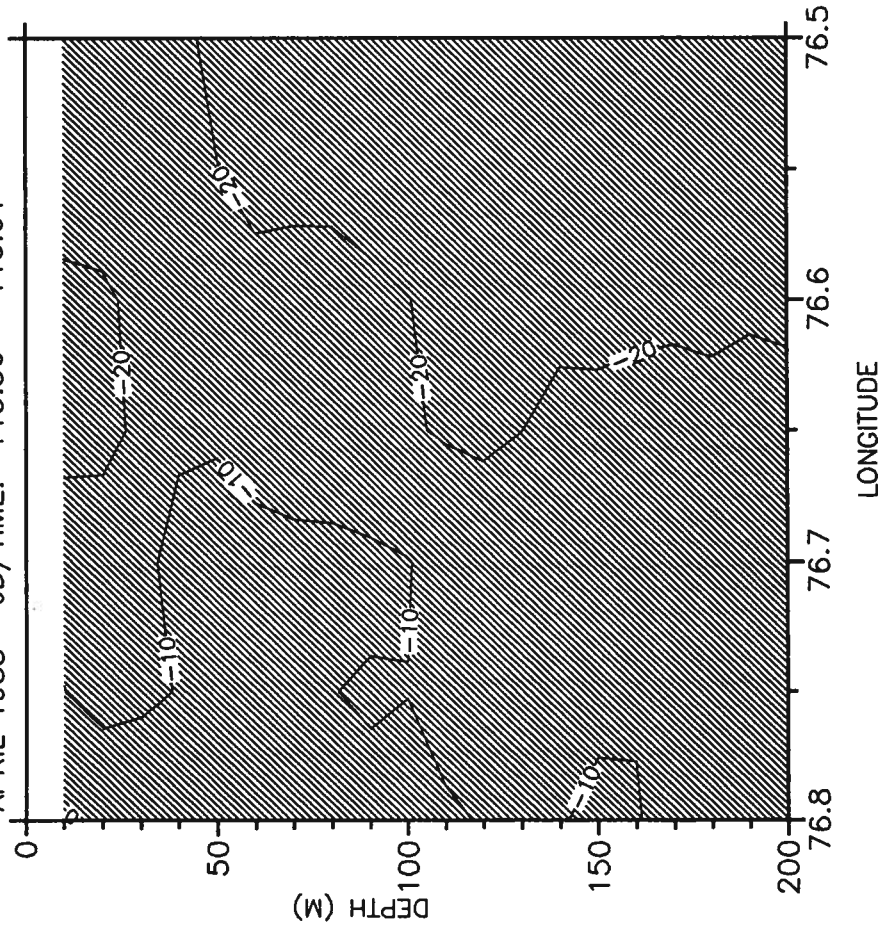

V-VELOCITY SECTION 4 (LORAN)

APRIL 1985 JD/TIME: 113.56 - 115.01

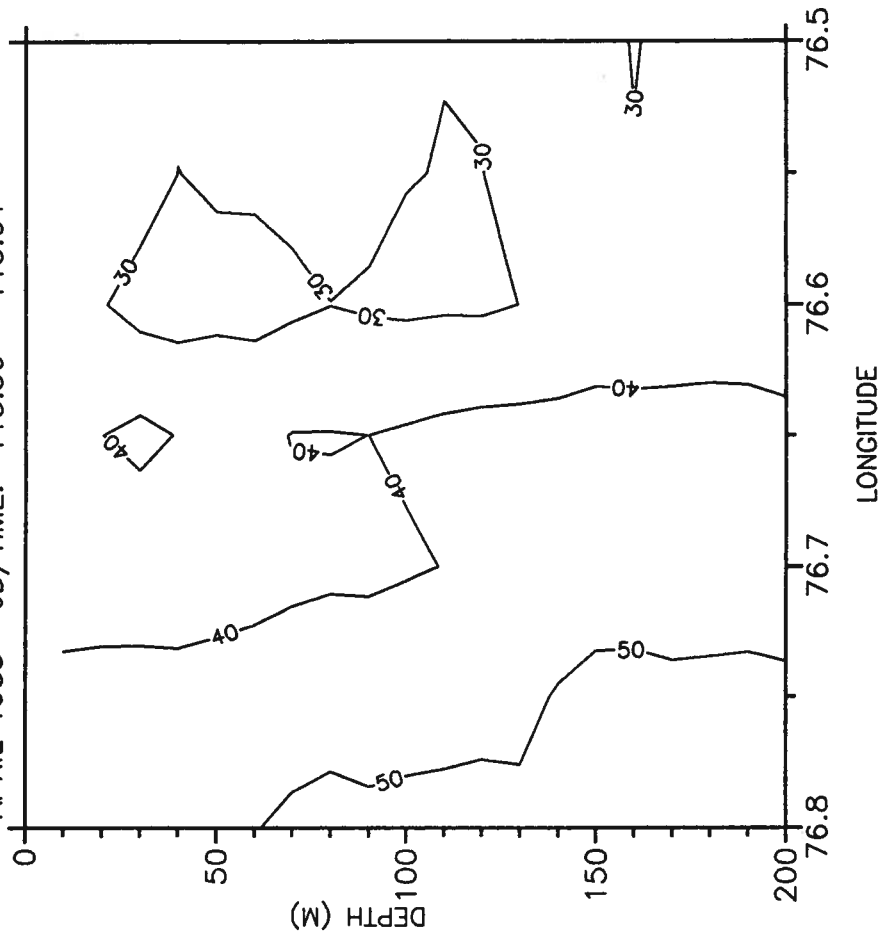

U-VELOCITY SECTION 4 (LORAN)  
 APRIL 1985 JD/TIME: 115.24 - 116.07

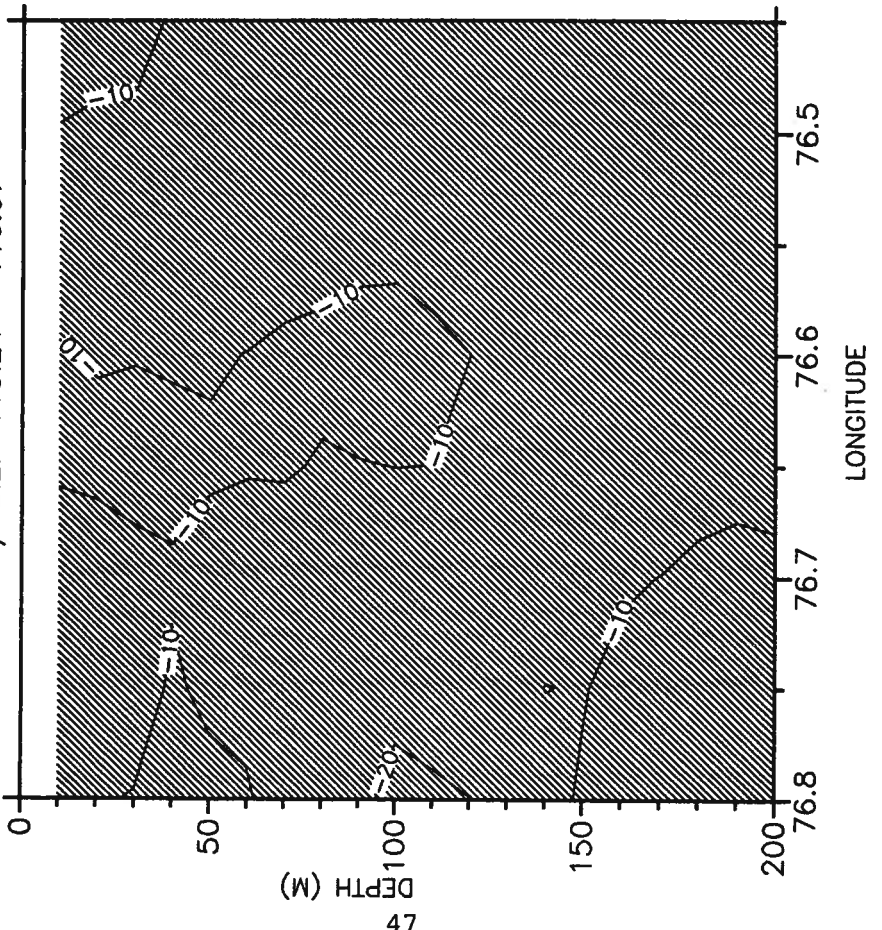

V-VELOCITY SECTION 4 (LORAN)  
 APRIL 1985 JD/TIME: 115.24 - 116.07

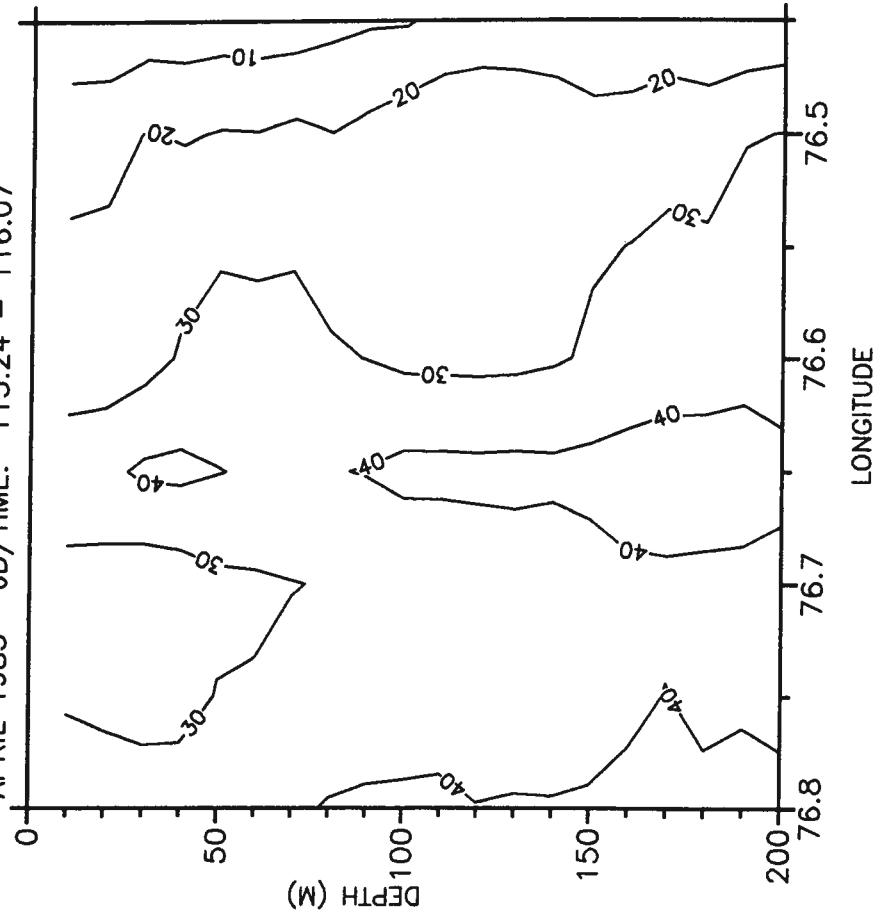

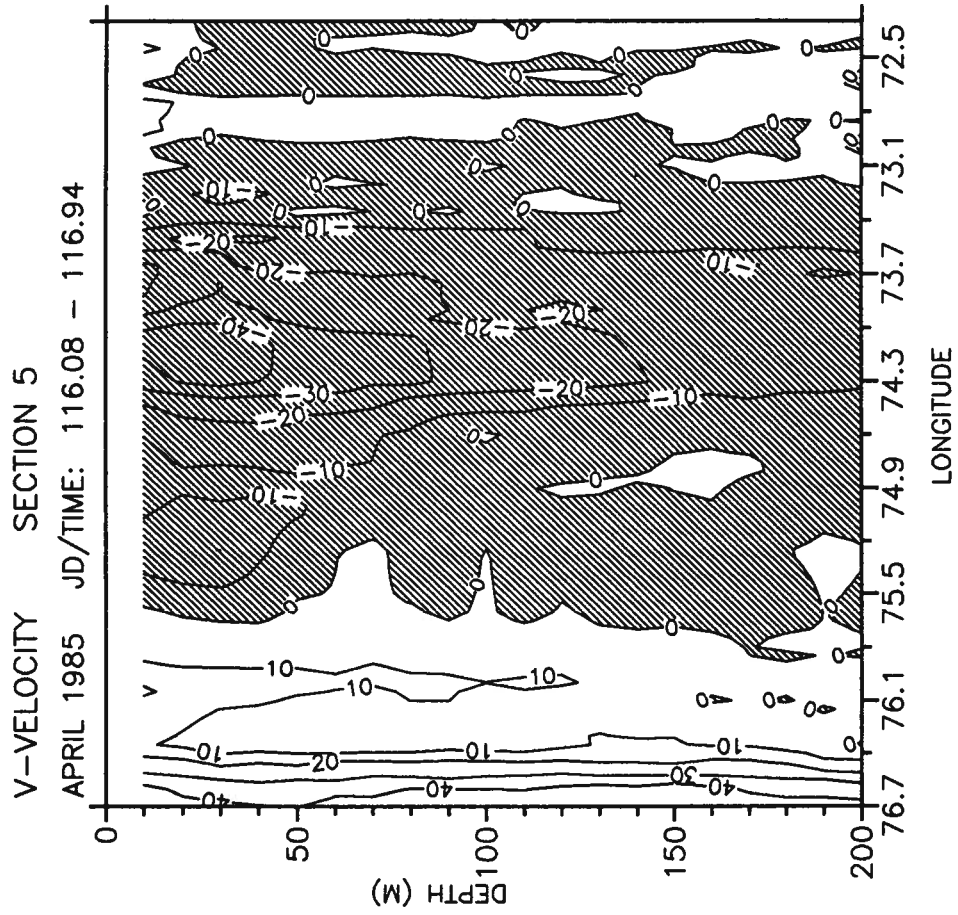
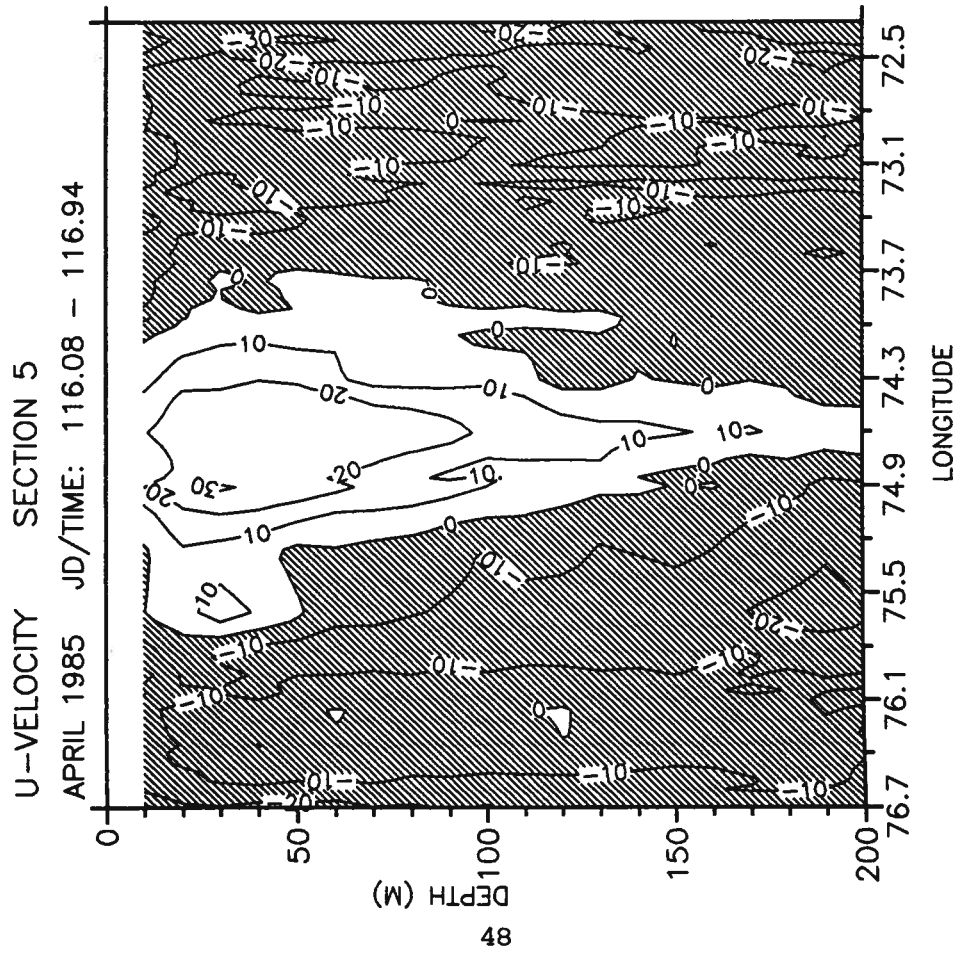

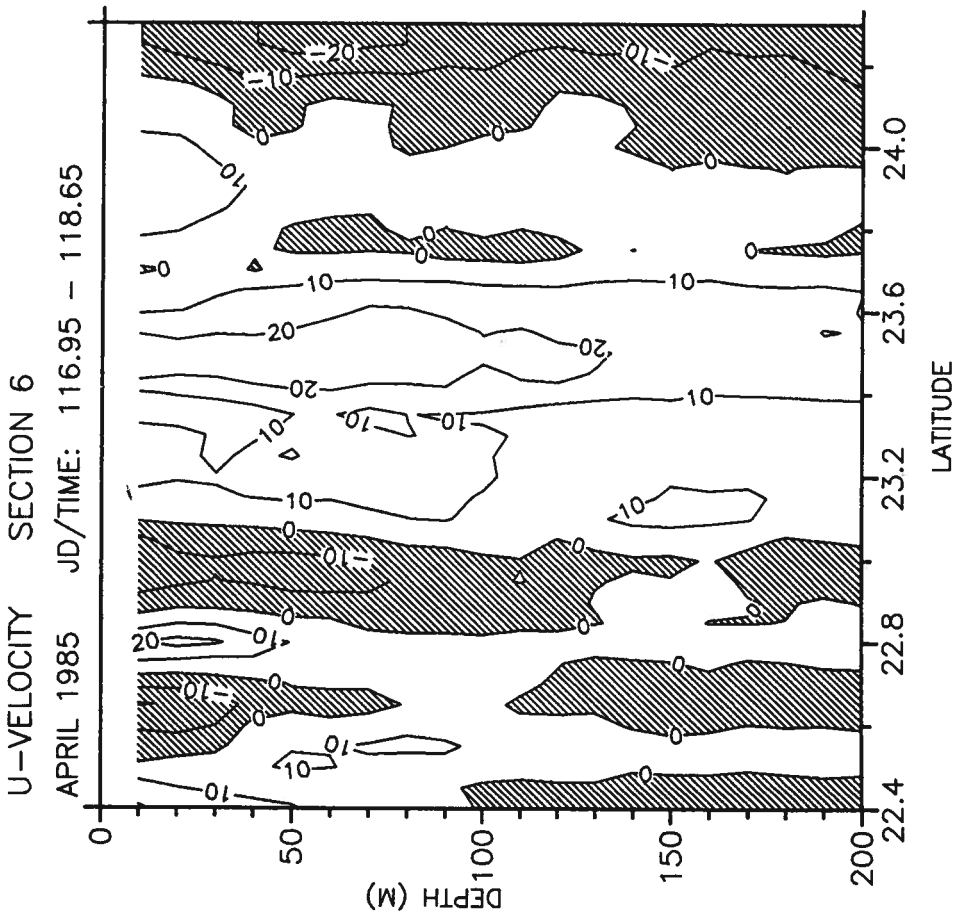
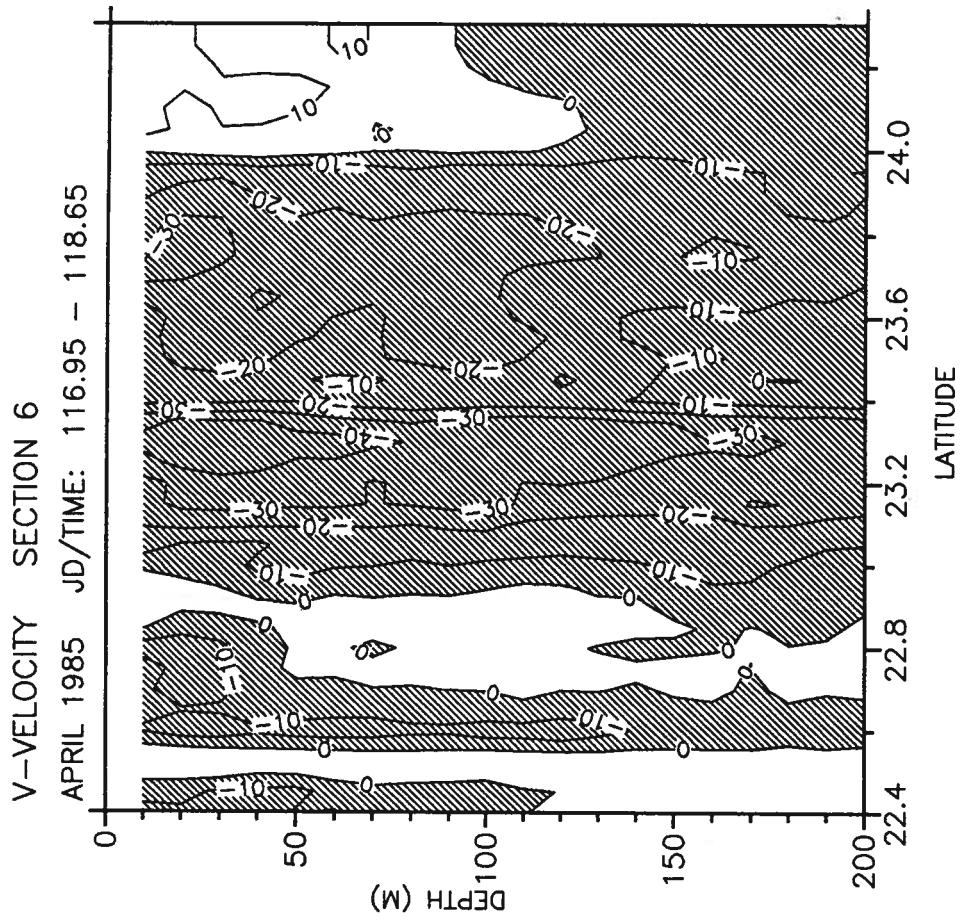

V-VELOCITY SECTION 7

APRIL 1985 JD/TIME: 118.74 - 120.11

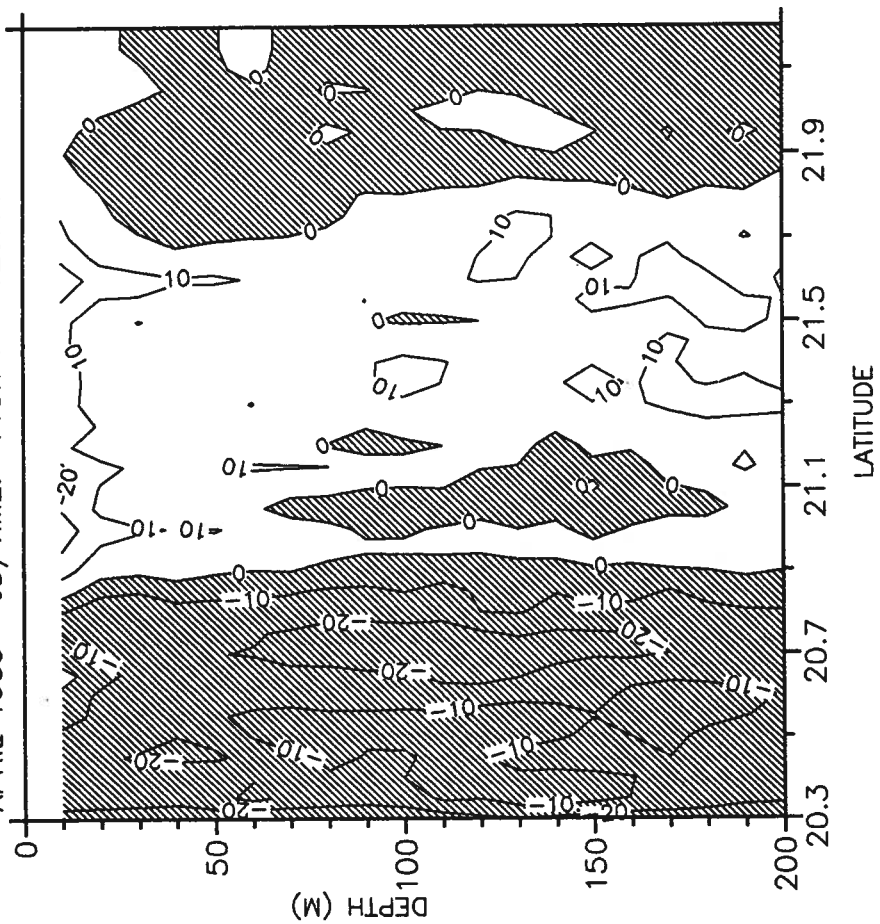

U-VELOCITY SECTION 7

APRIL 1985 JD/TIME: 118.74 - 120.11

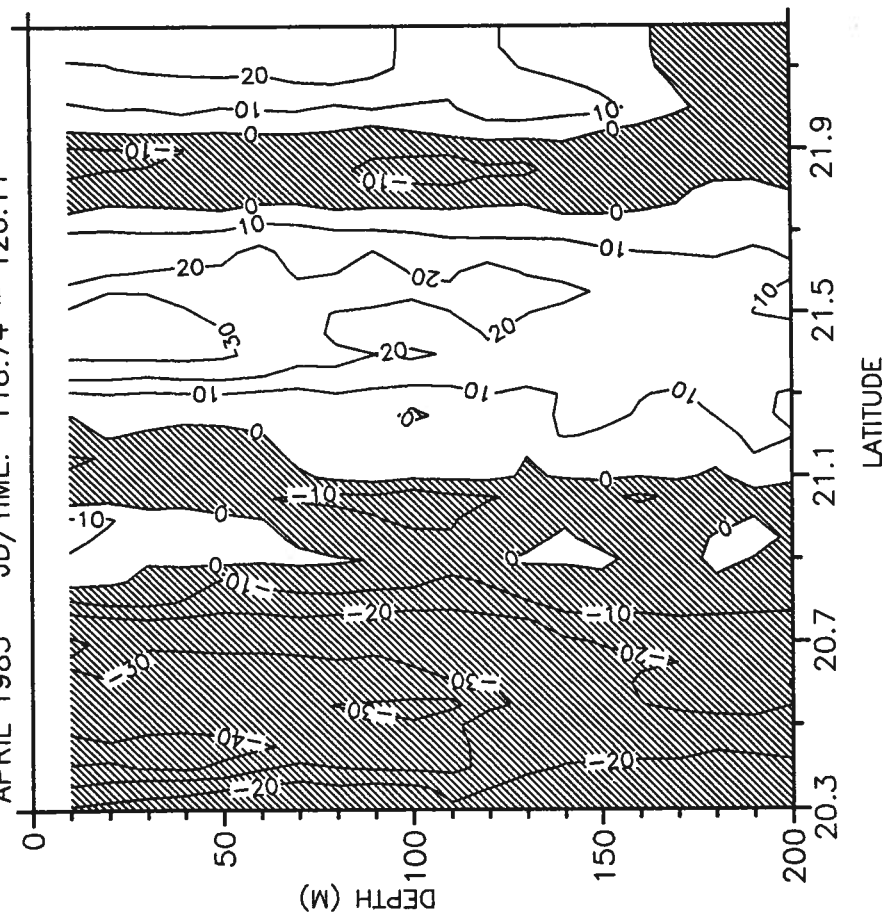

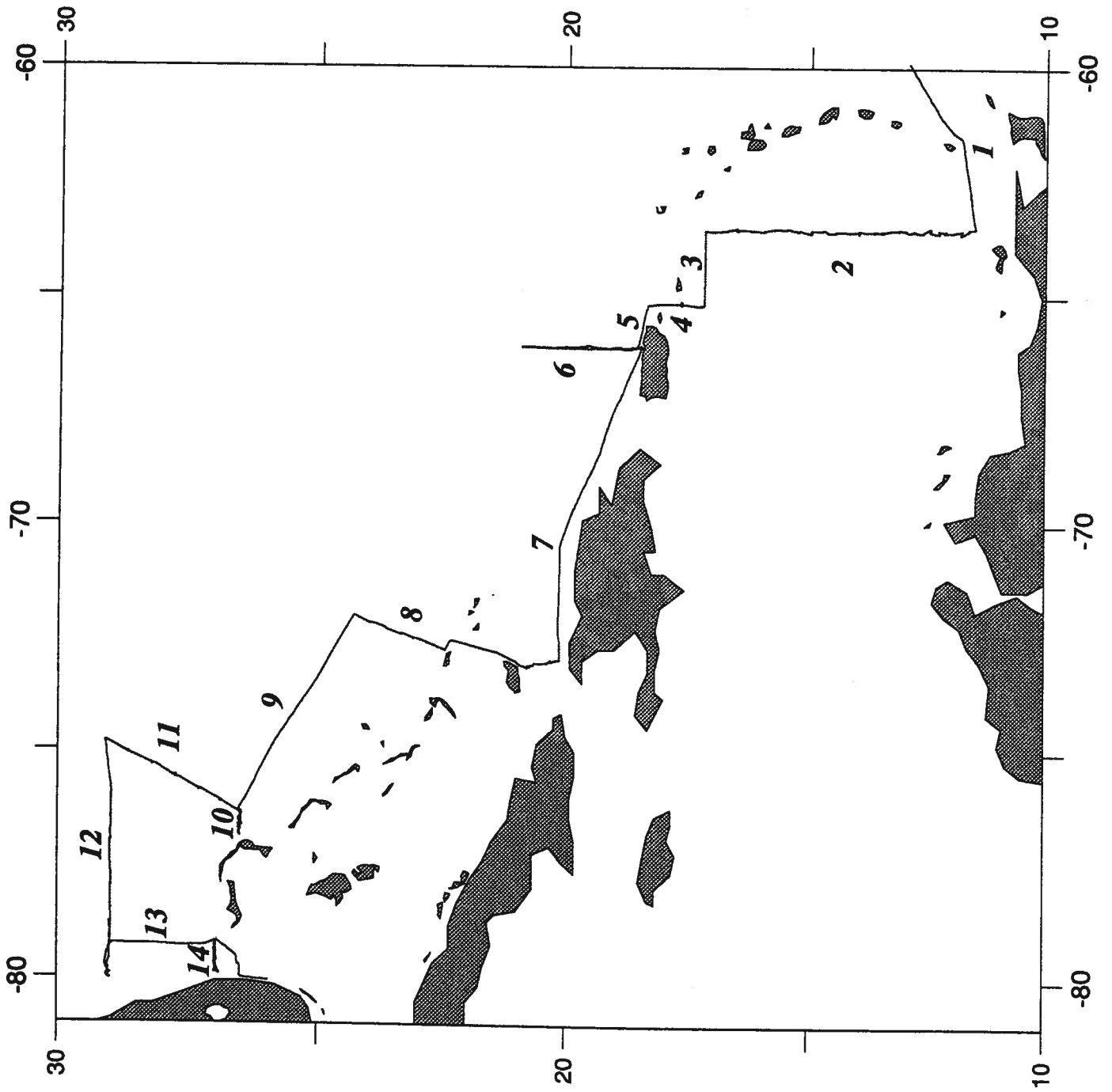

*Map of the Ametek-Straza (ADCP) trackline - August 1985*

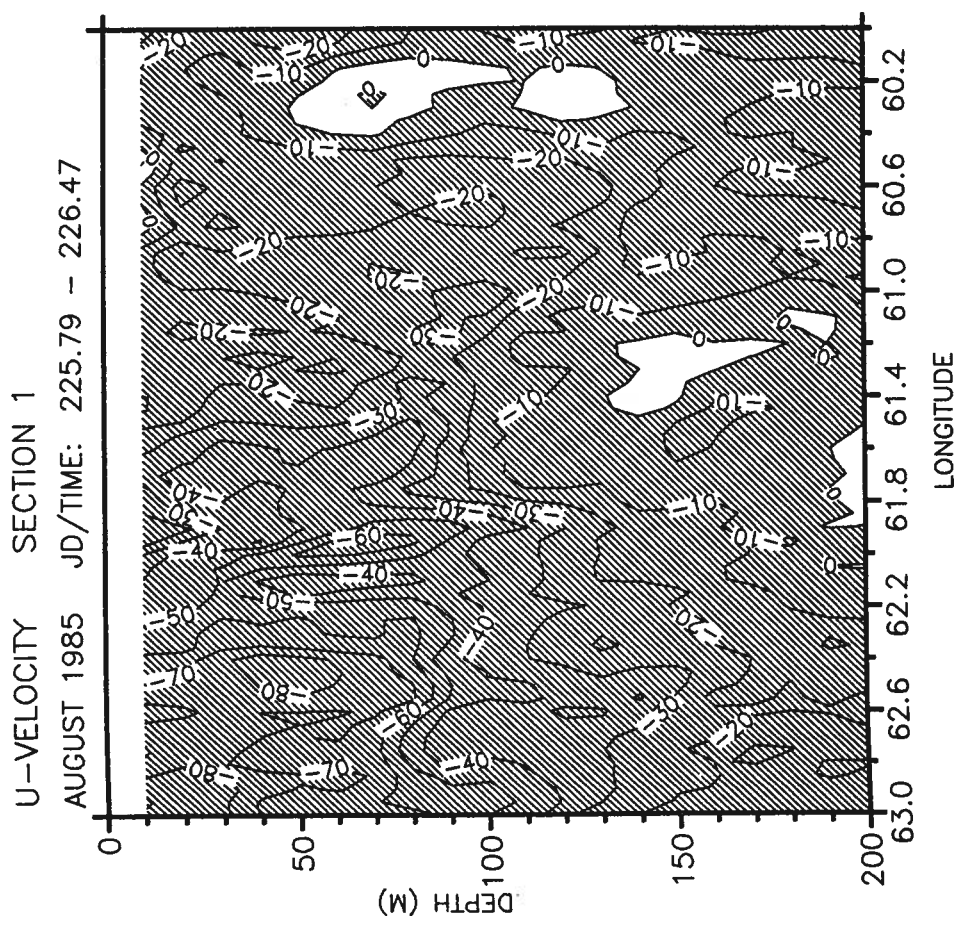
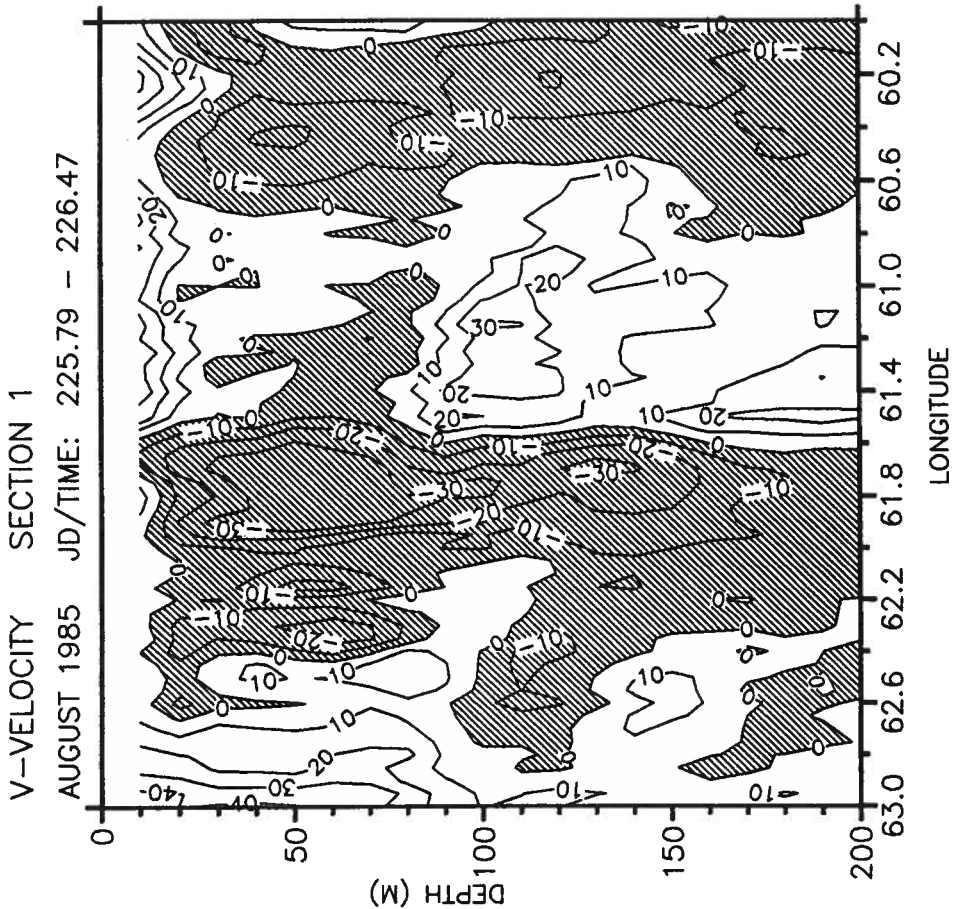



V-VELOCITY SECTION 2

AUGUST 1985 JD/TIME: 226.47 - 230.82

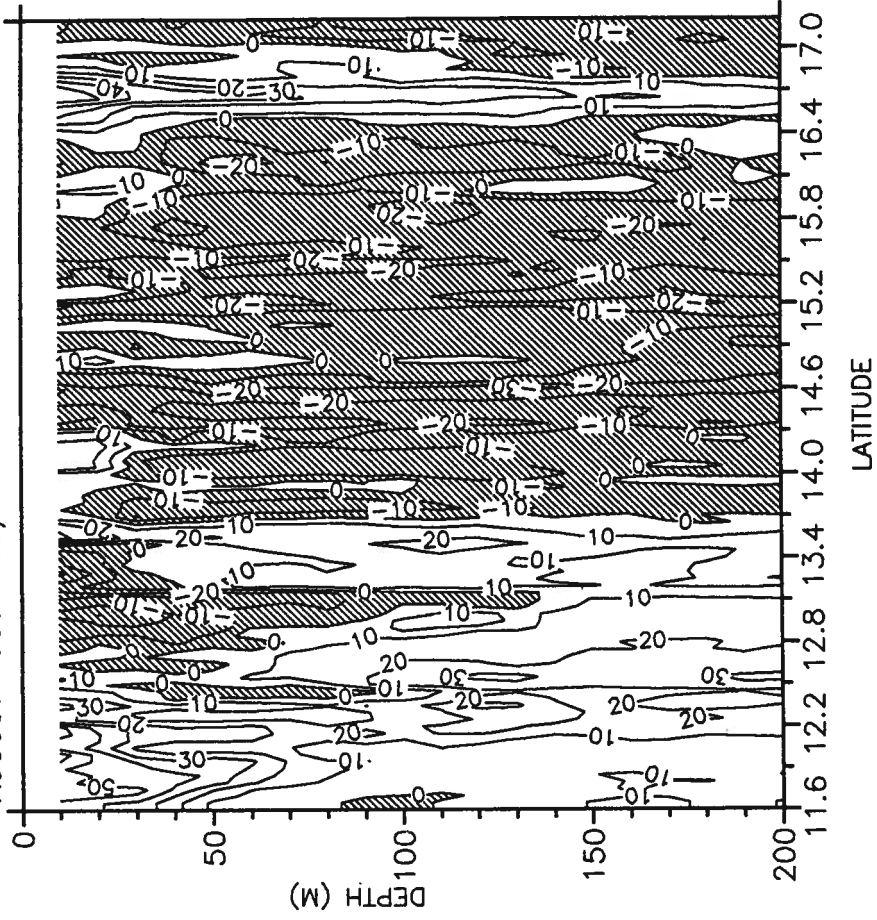

U-VELOCITY SECTION 2

AUGUST 1985 JD/TIME: 226.47 - 230.82

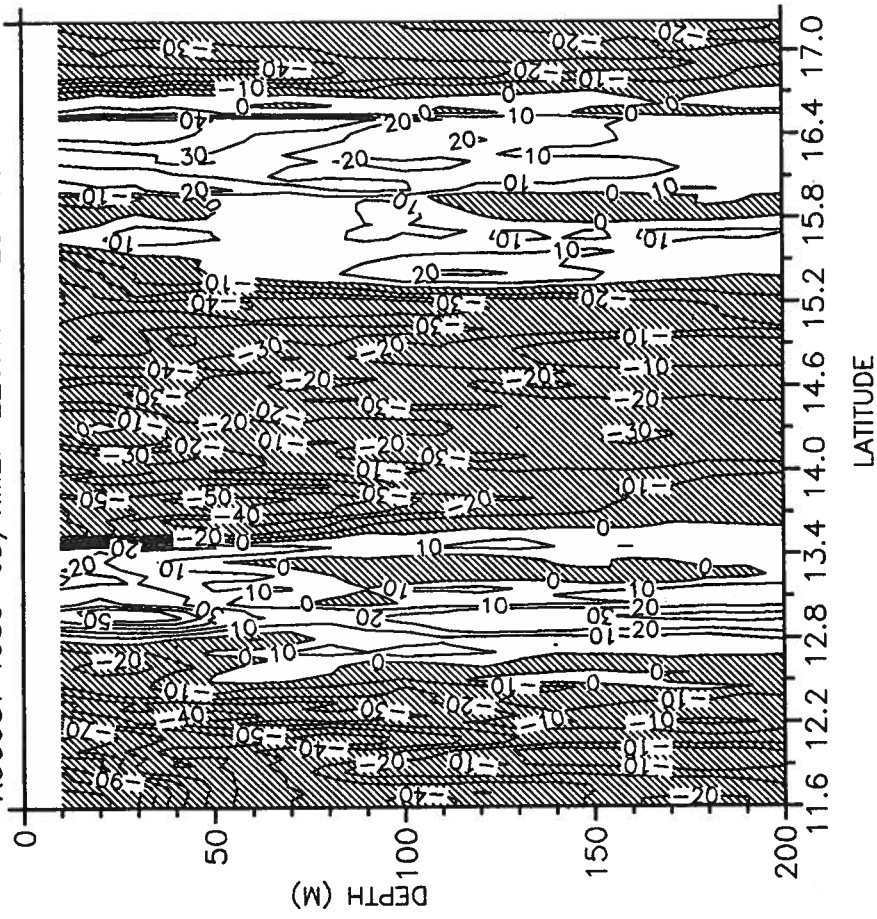



U-VELOCITY SECTION 3

AUGUST 1985 JD/TIME: 230.83 - 231.09

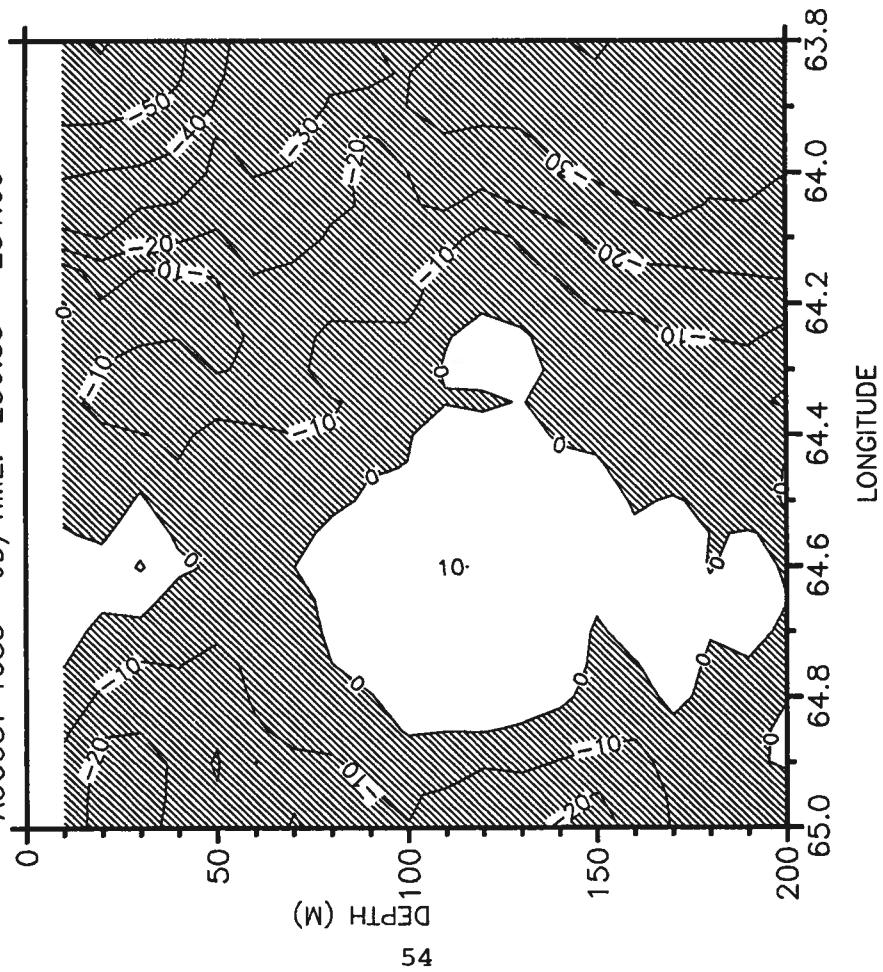

V-VELOCITY SECTION 3

AUGUST 1985 JD/TIME: 230.83 - 231.09

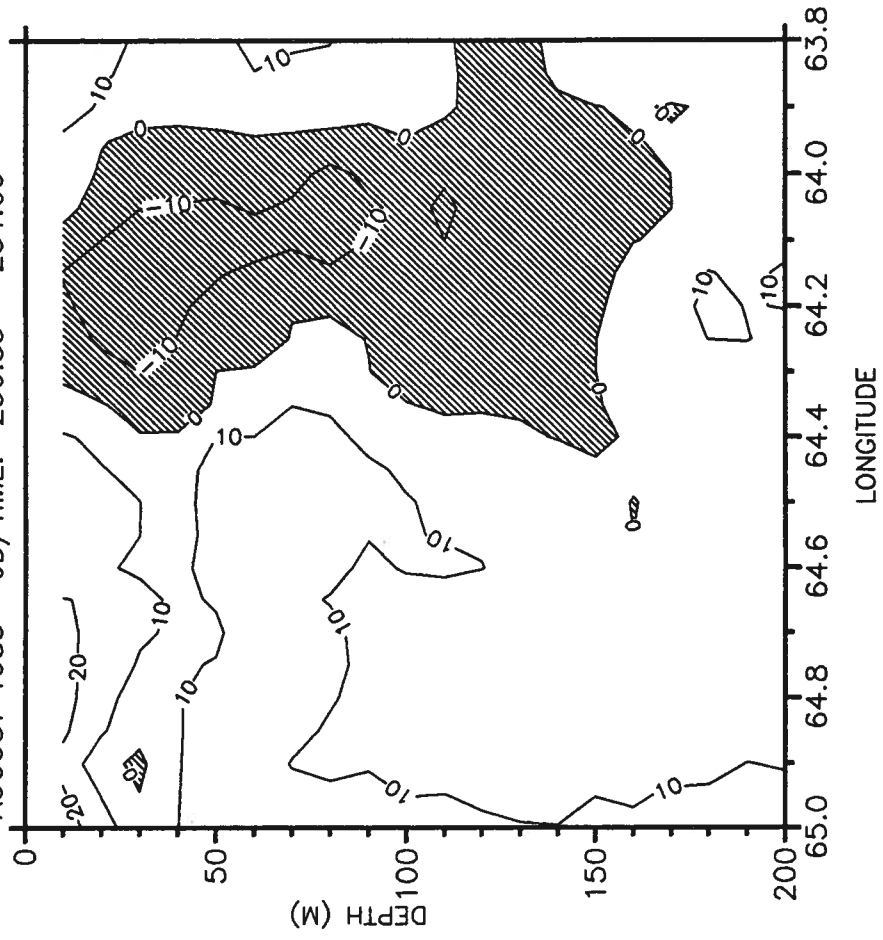

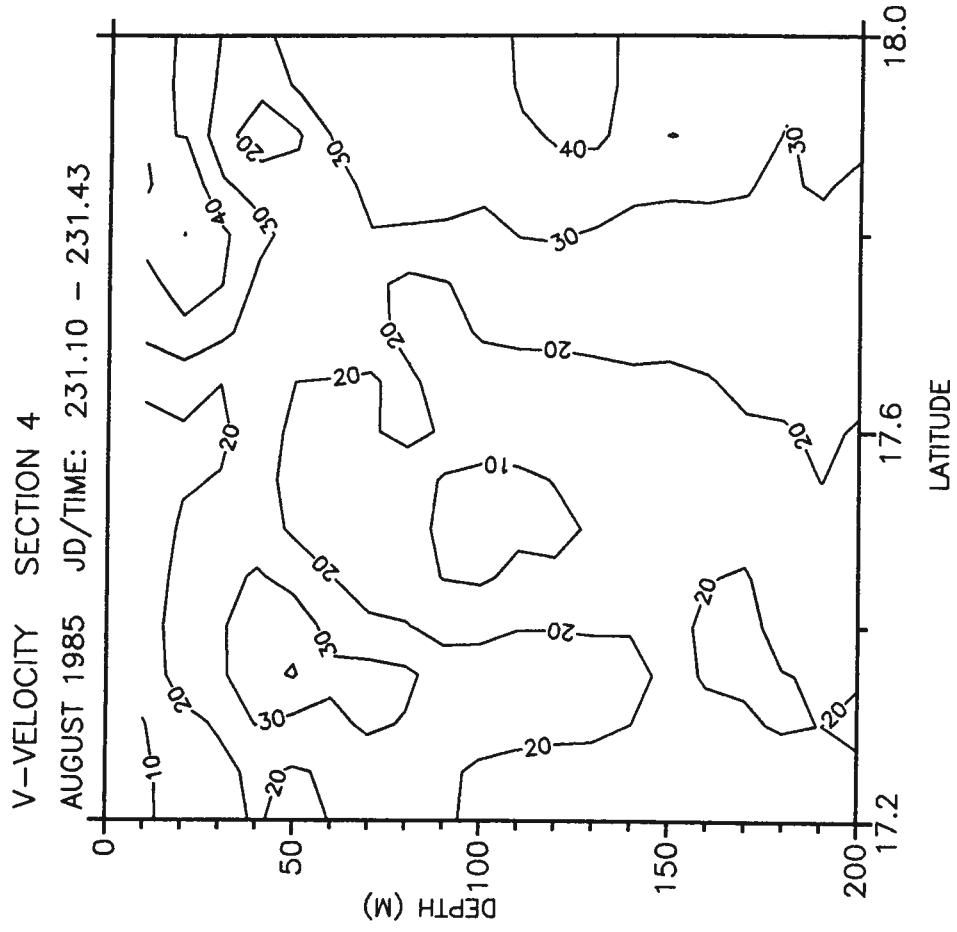
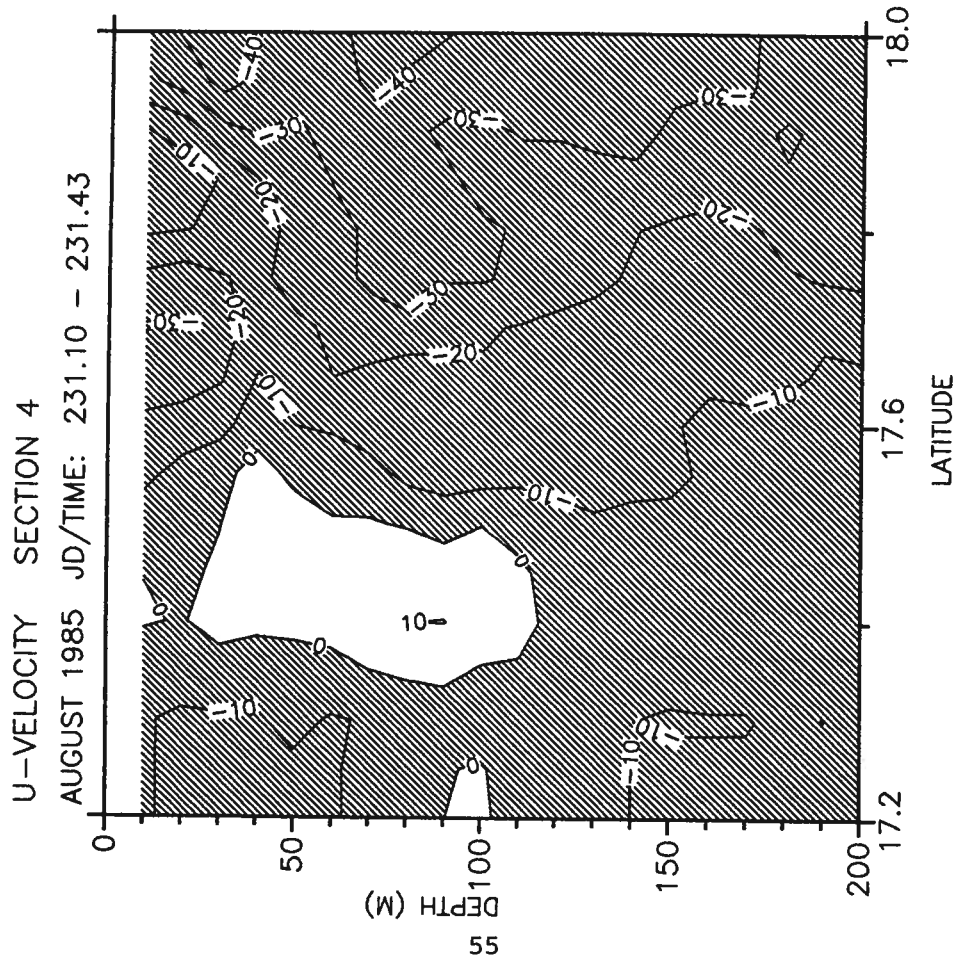

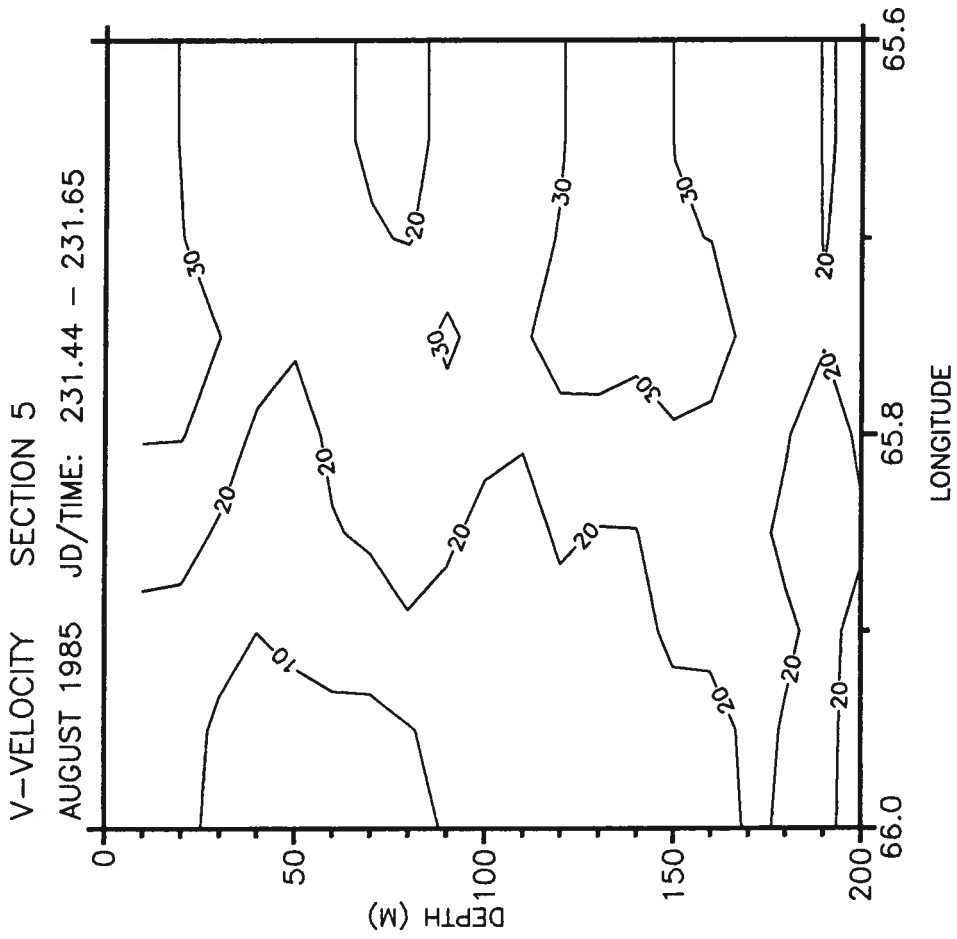
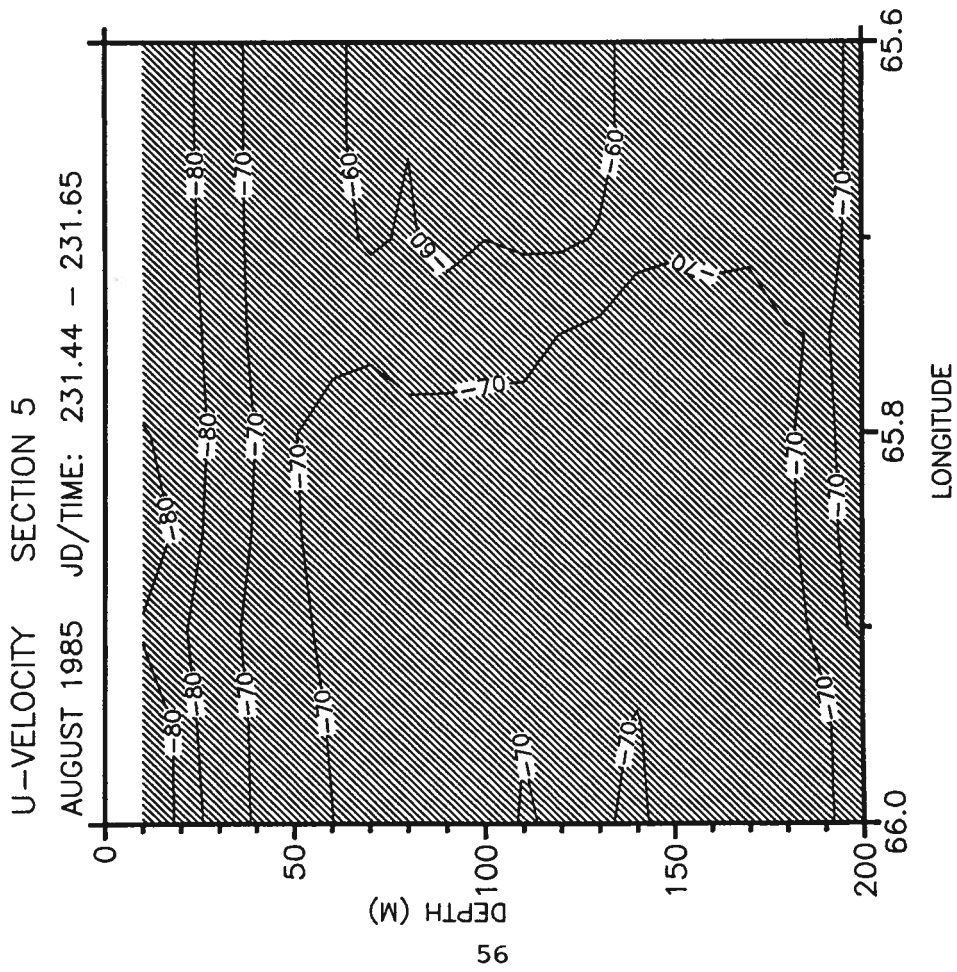

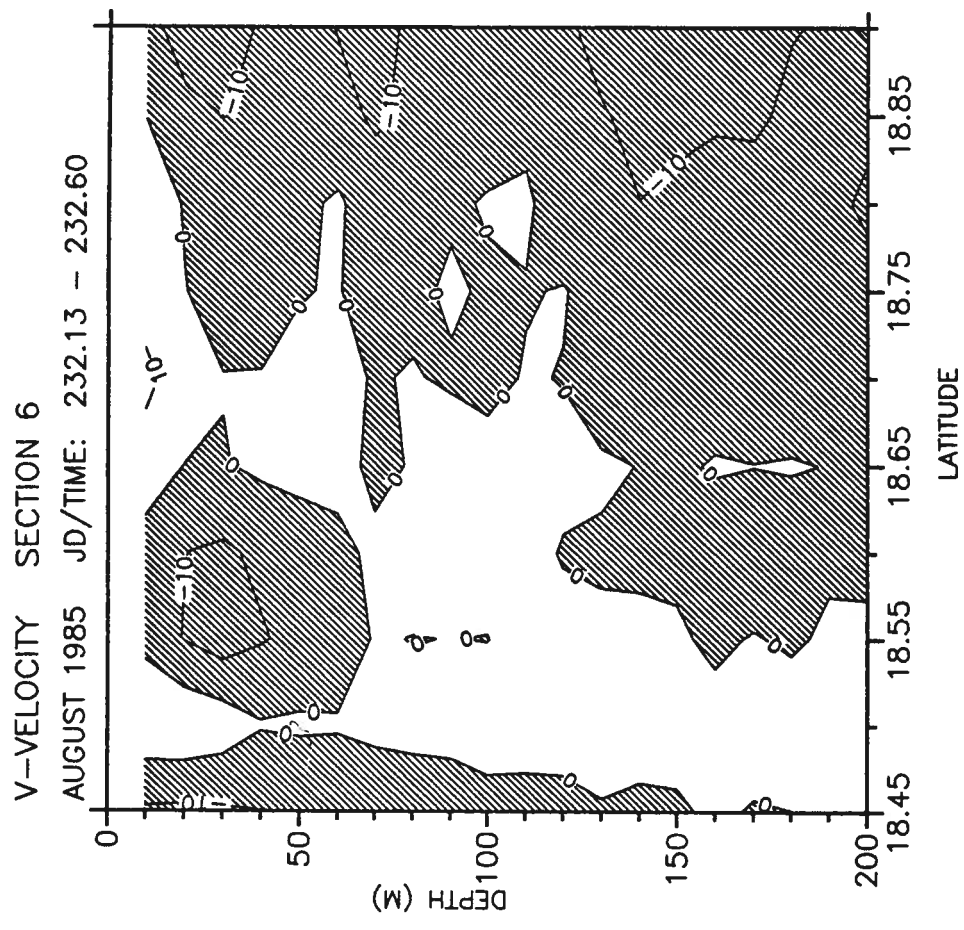
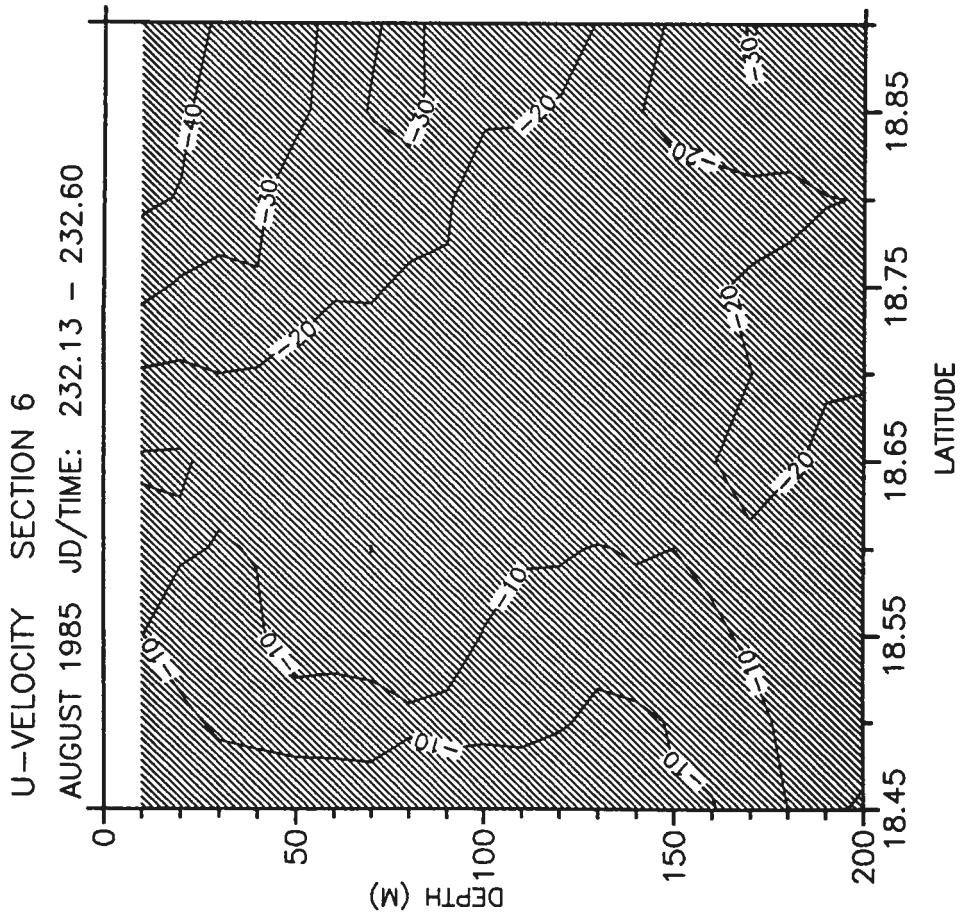

U-VELOCITY SECTION 6

AUGUST 1985 JD/TIME: 232.13 - 232.60

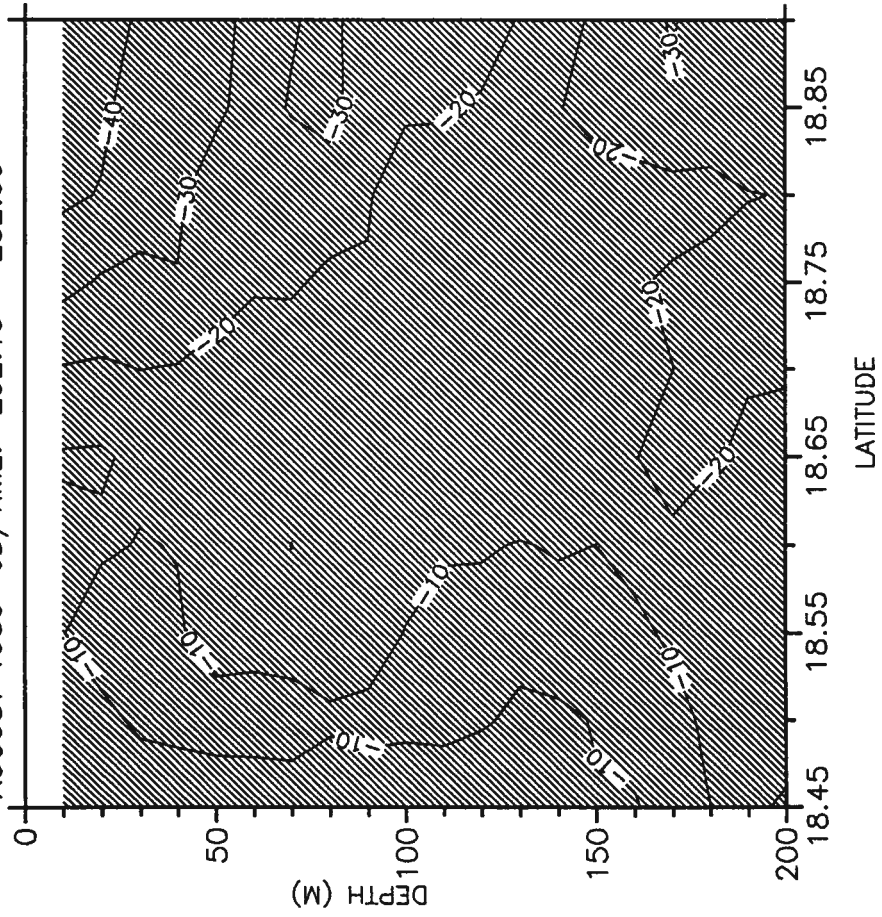

V-VELOCITY SECTION 6

AUGUST 1985 JD/TIME: 232.13 - 232.60

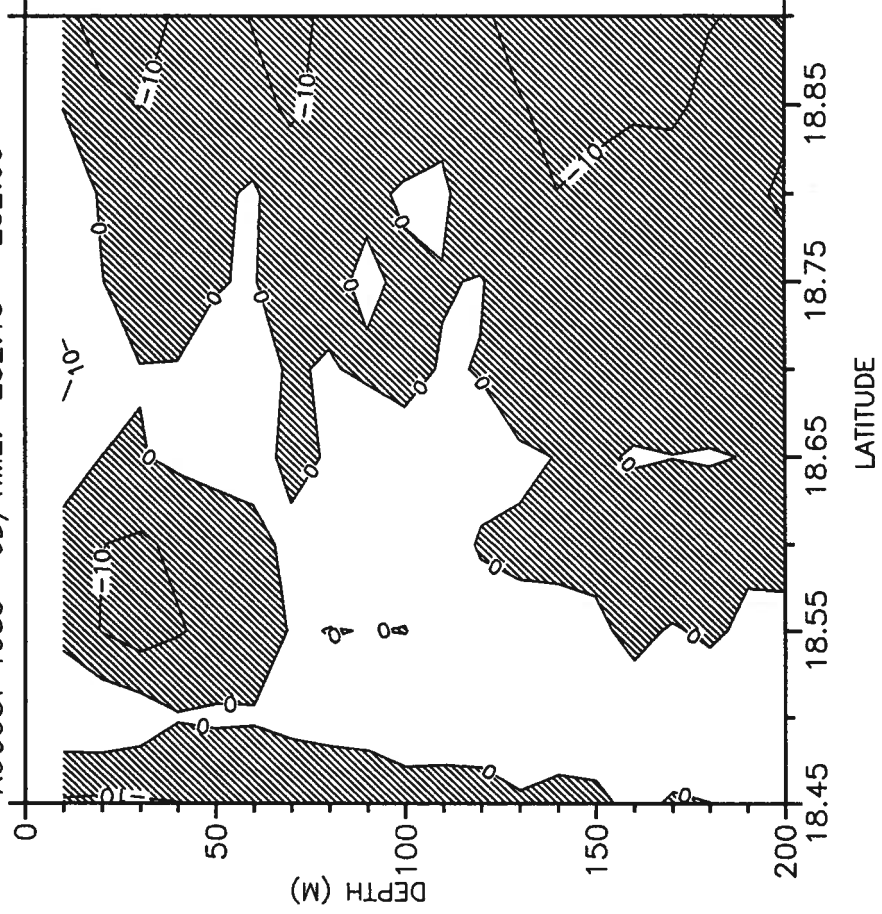

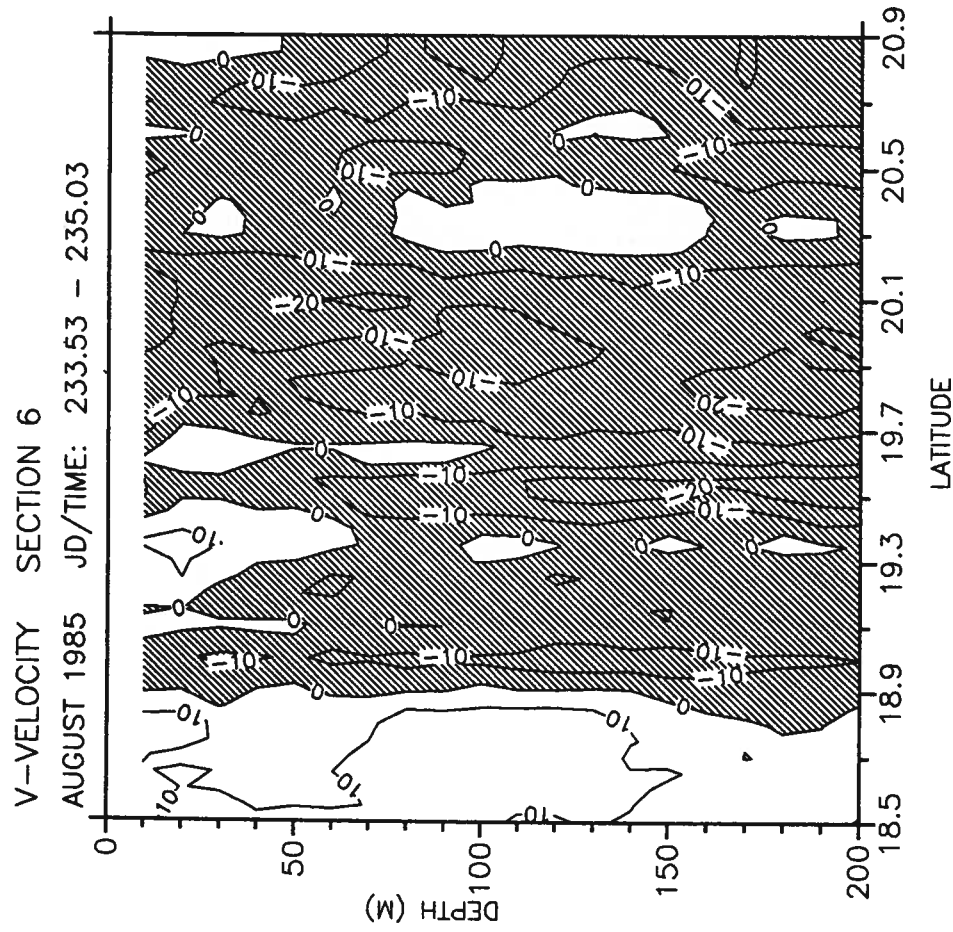
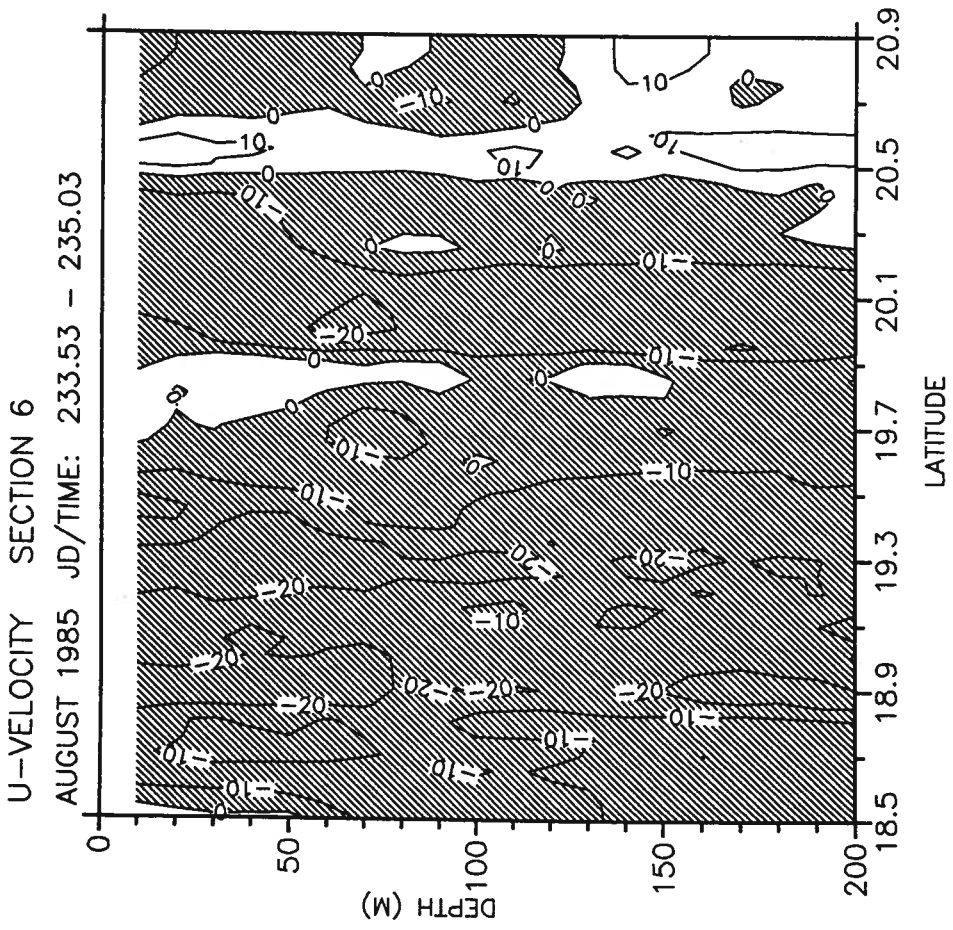

U-VELOCITY SECTION 6

AUGUST 1985 JD/TIME: 235.04 - 235.57

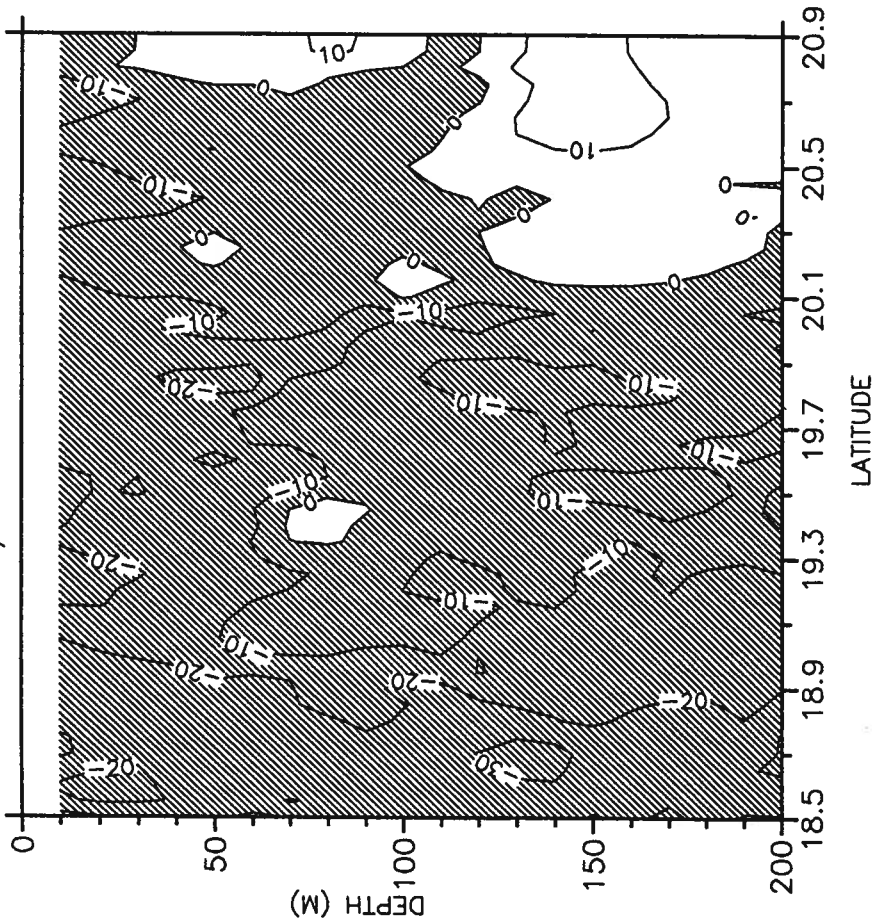

V-VELOCITY SECTION 6

AUGUST 1985 JD/TIME: 235.04 - 235.57

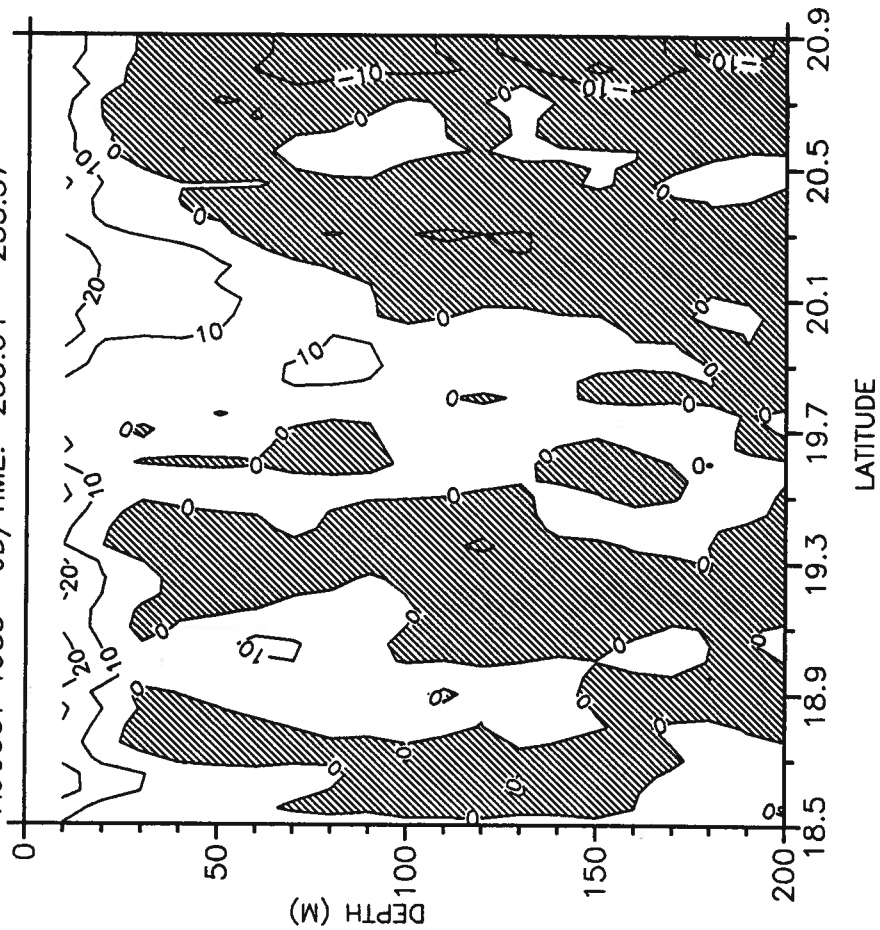



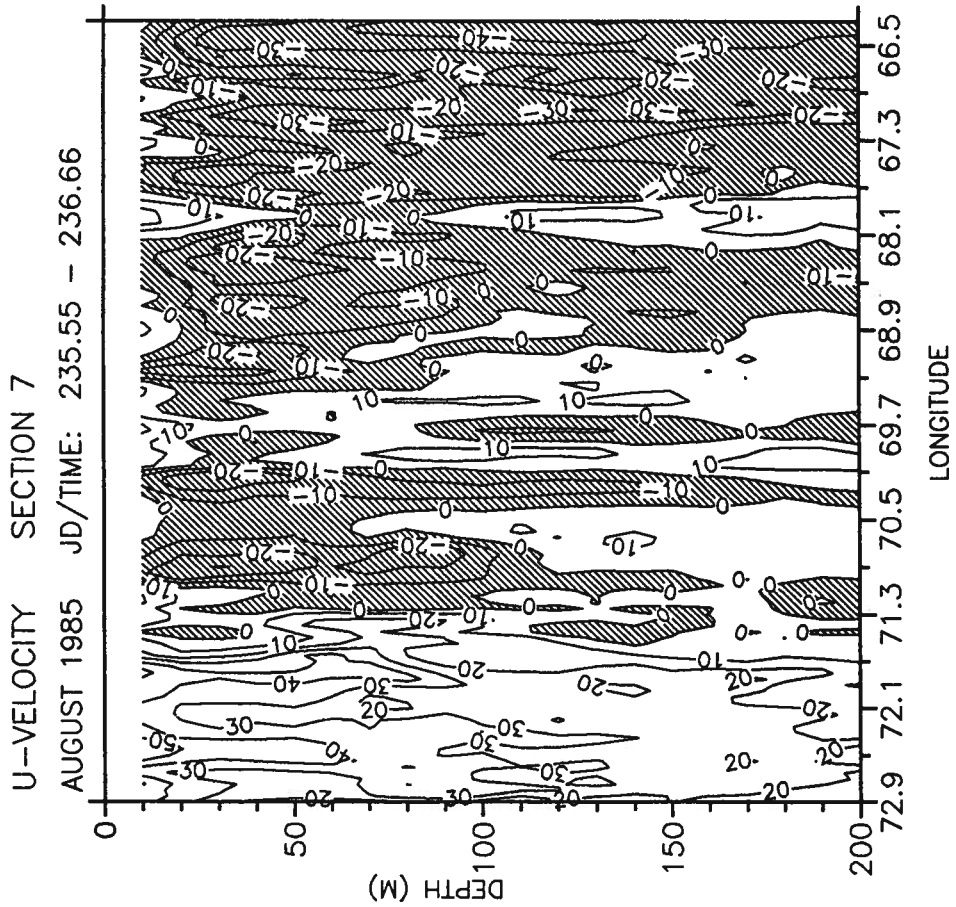
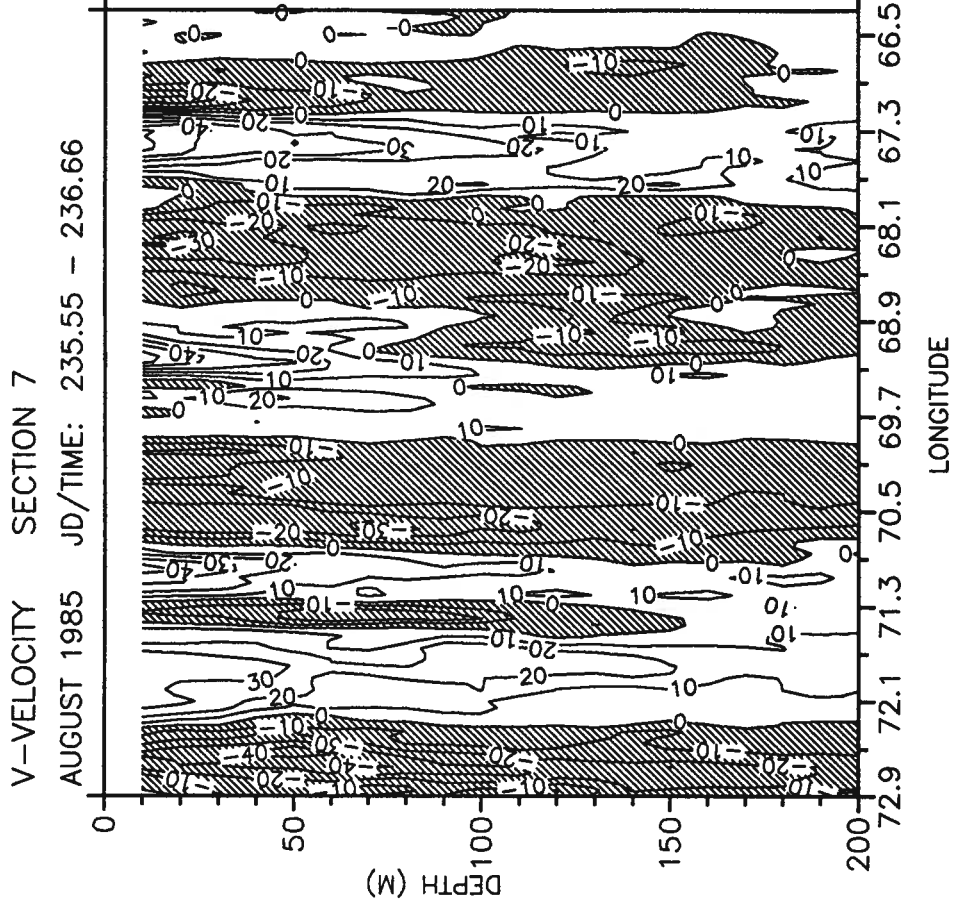



U-VELOCITY SECTION 8

AUGUST 1985 JD/TIME: 236.67 - 239.47

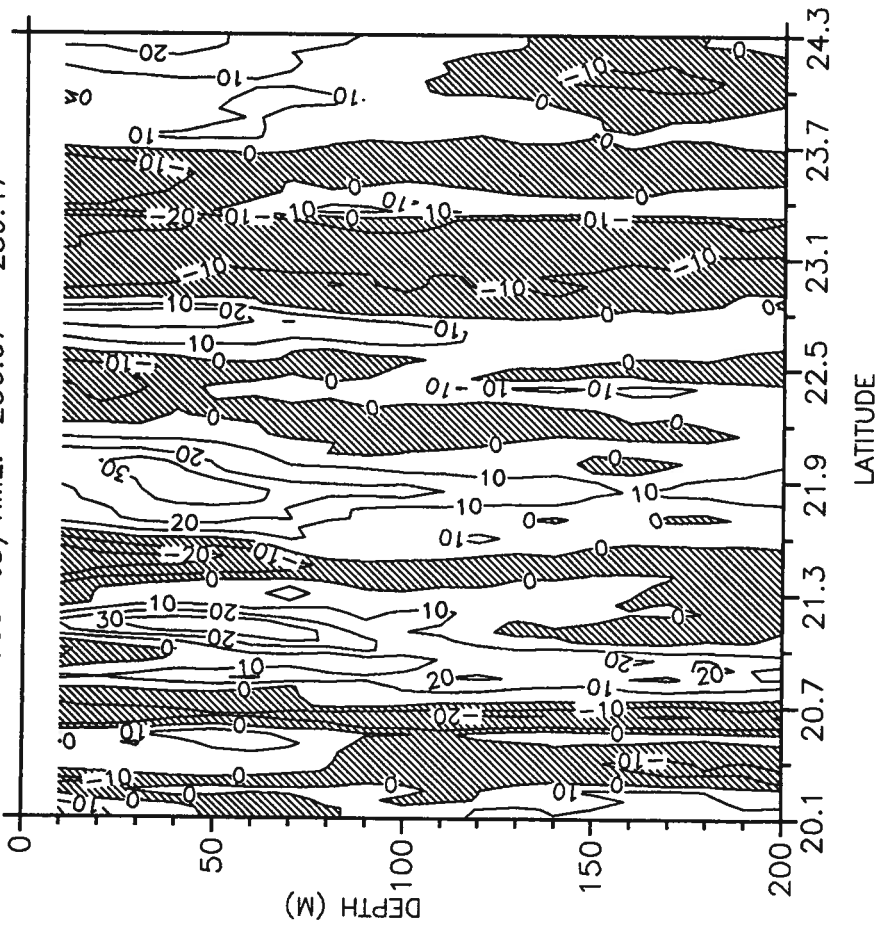

V-VELOCITY SECTION 8

AUGUST 1985 JD/TIME: 236.67 - 239.47

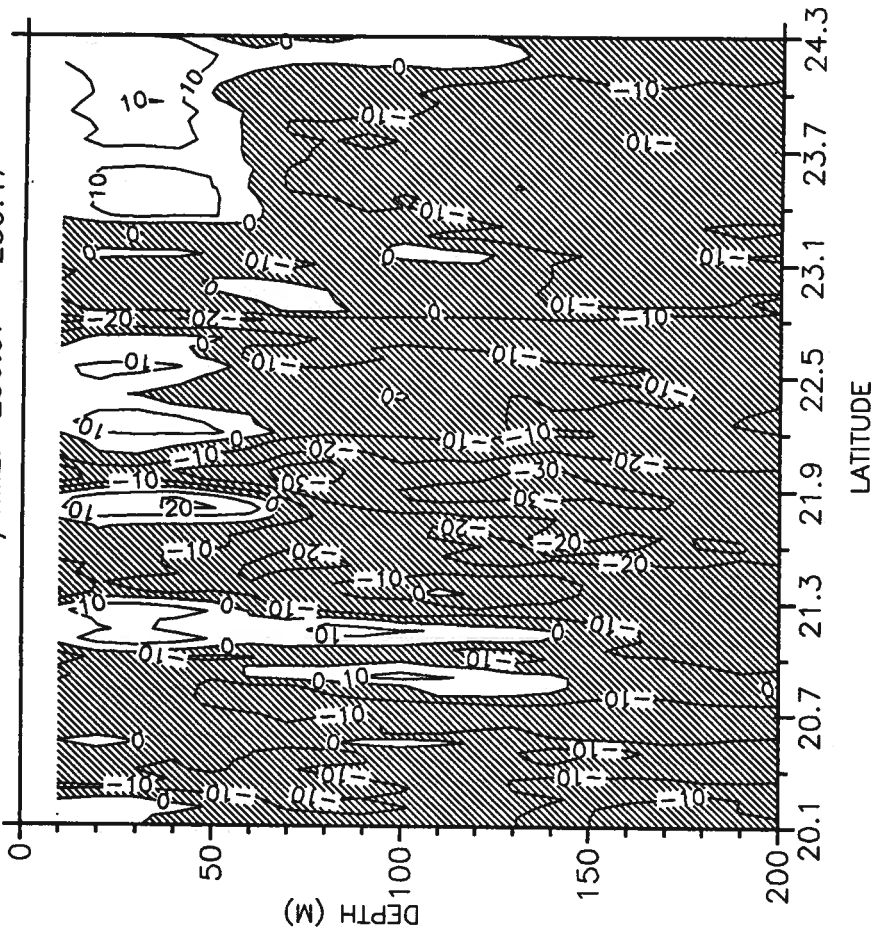

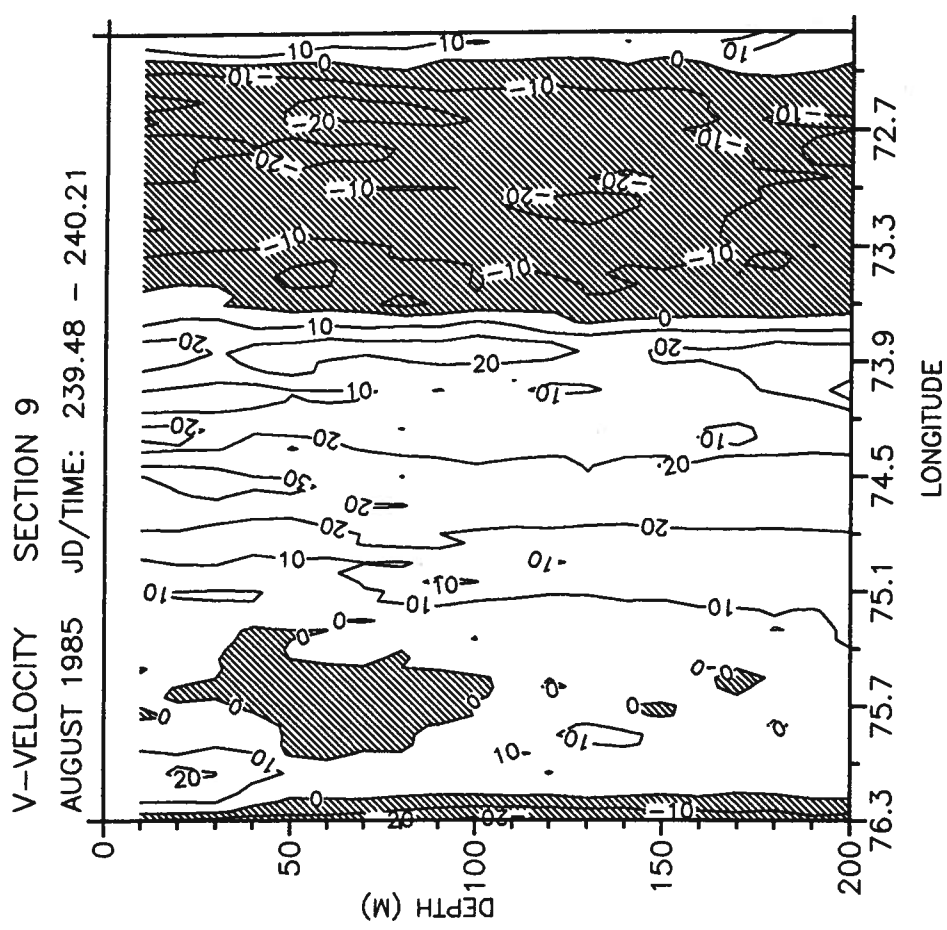
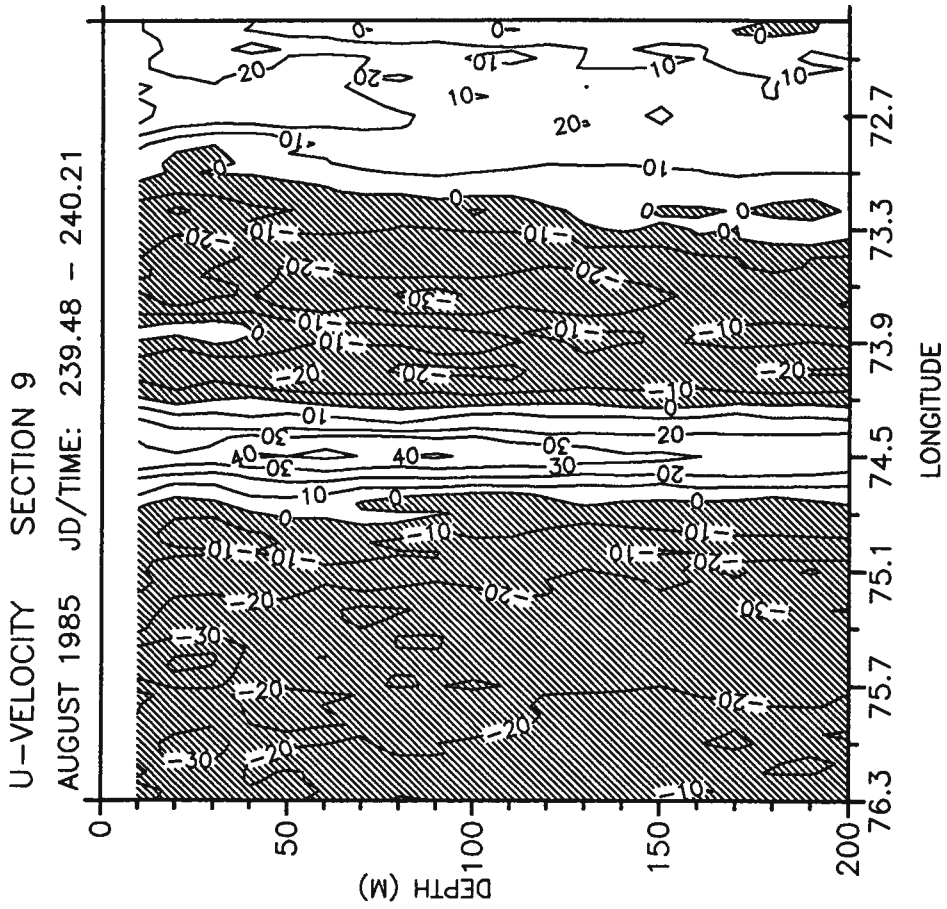

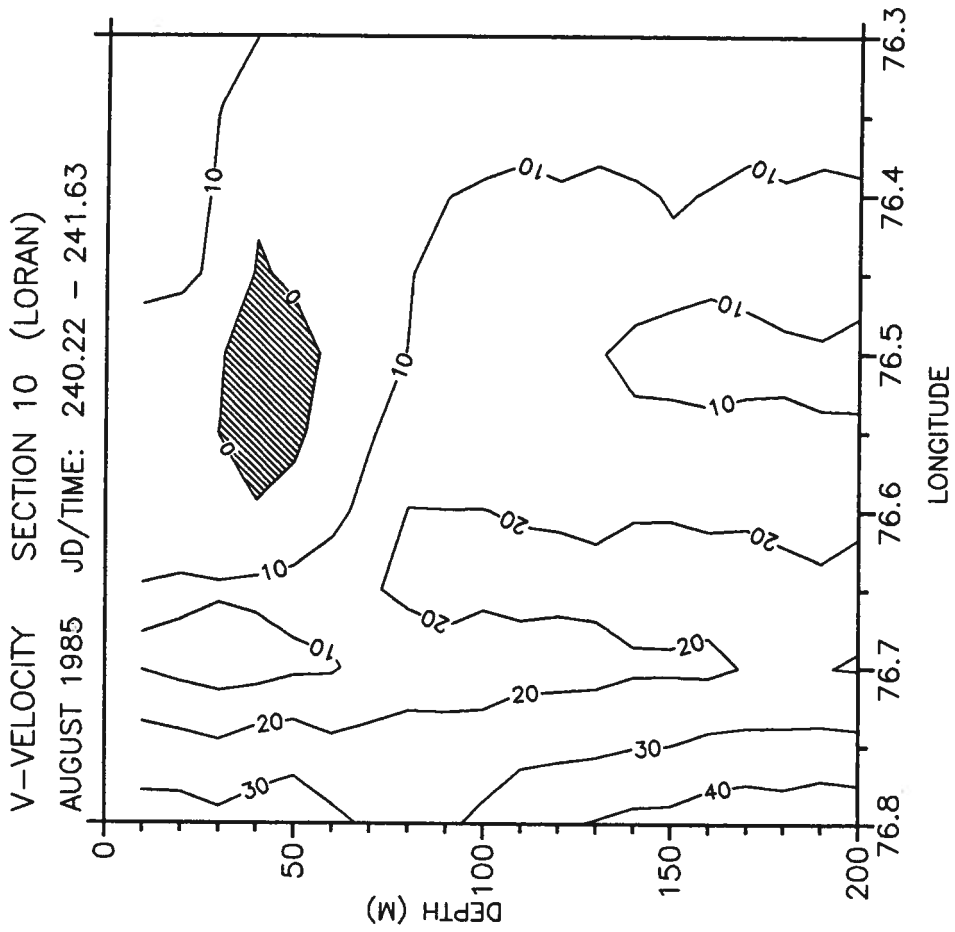
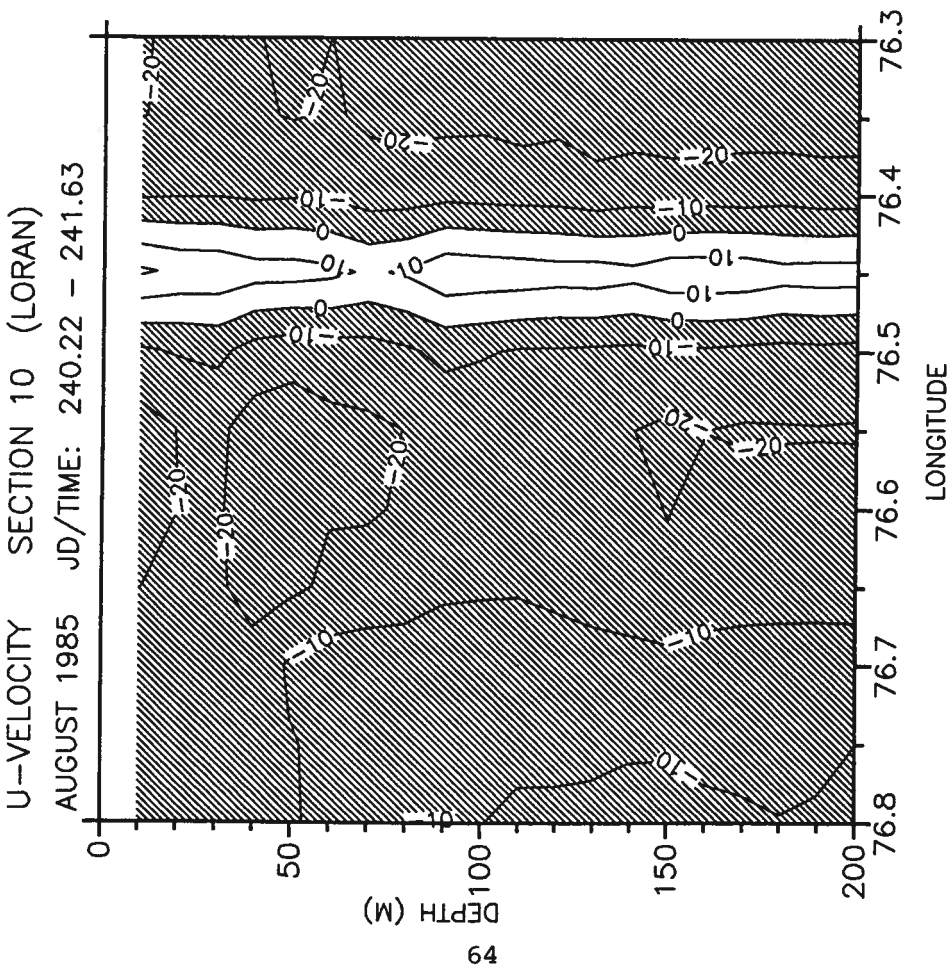

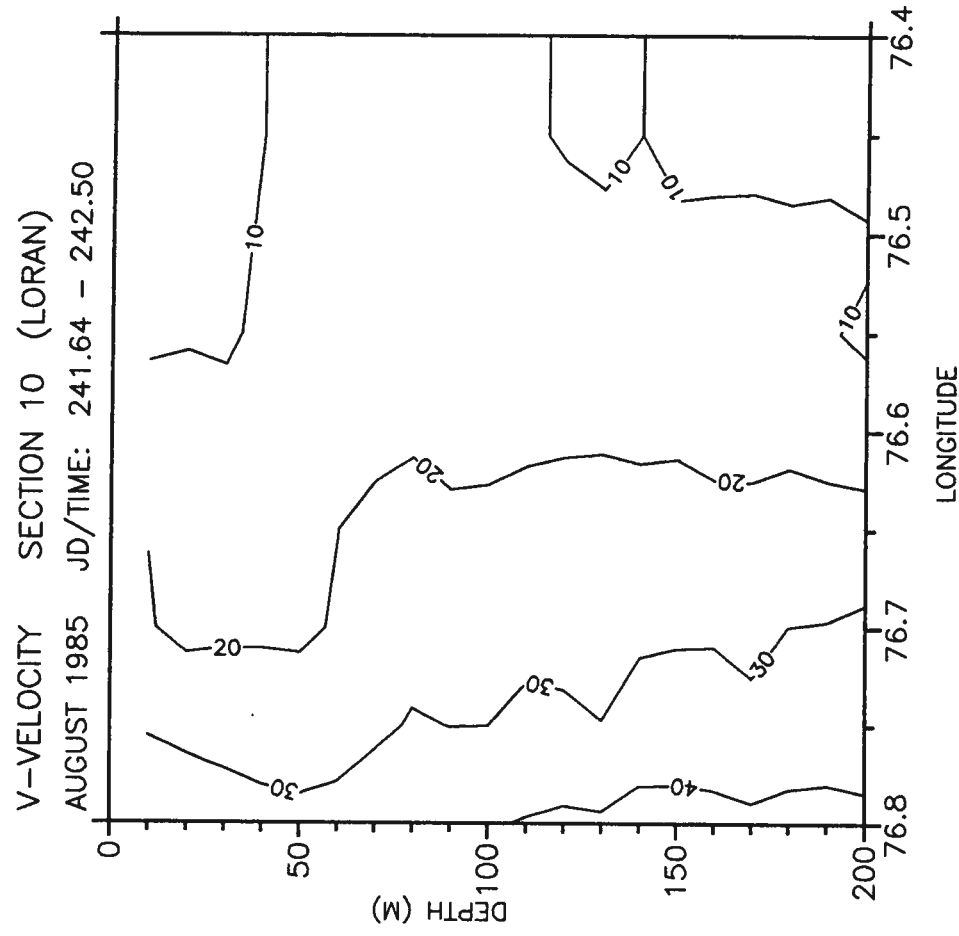
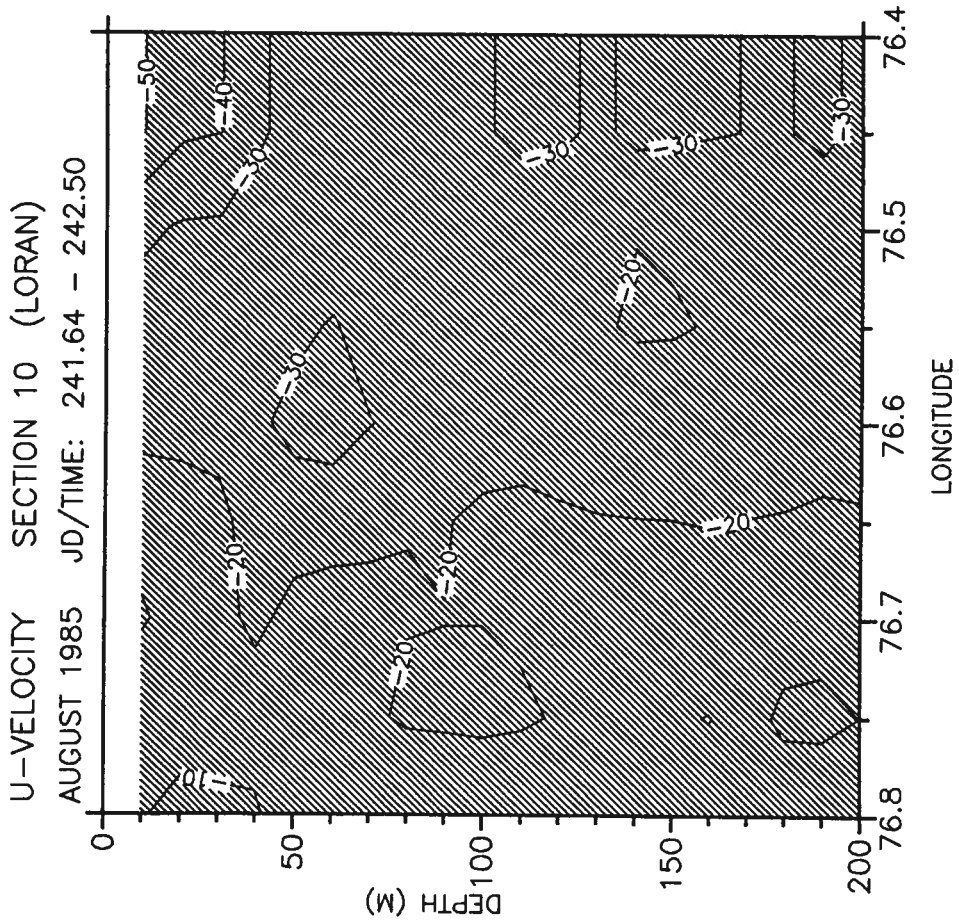

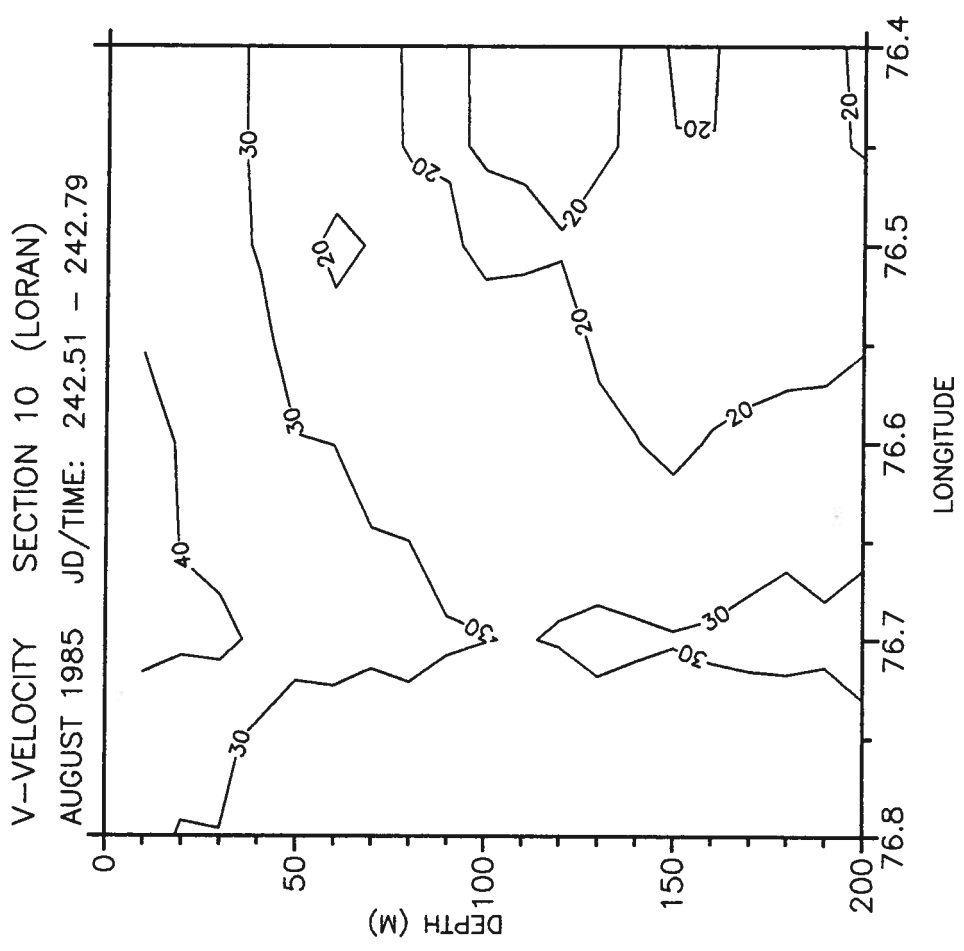
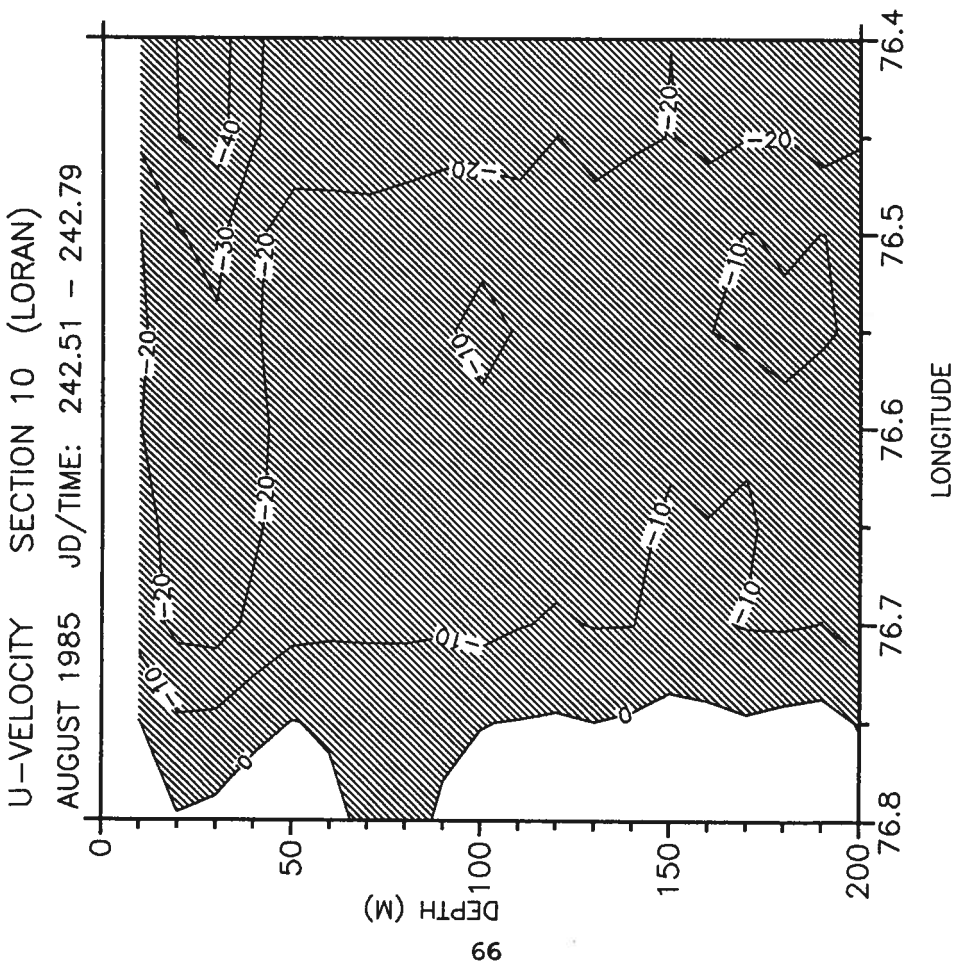

U-VELOCITY SECTION 11 (LORAN)

AUGUST 1985 JD/TIME: 243.38 - 244.94

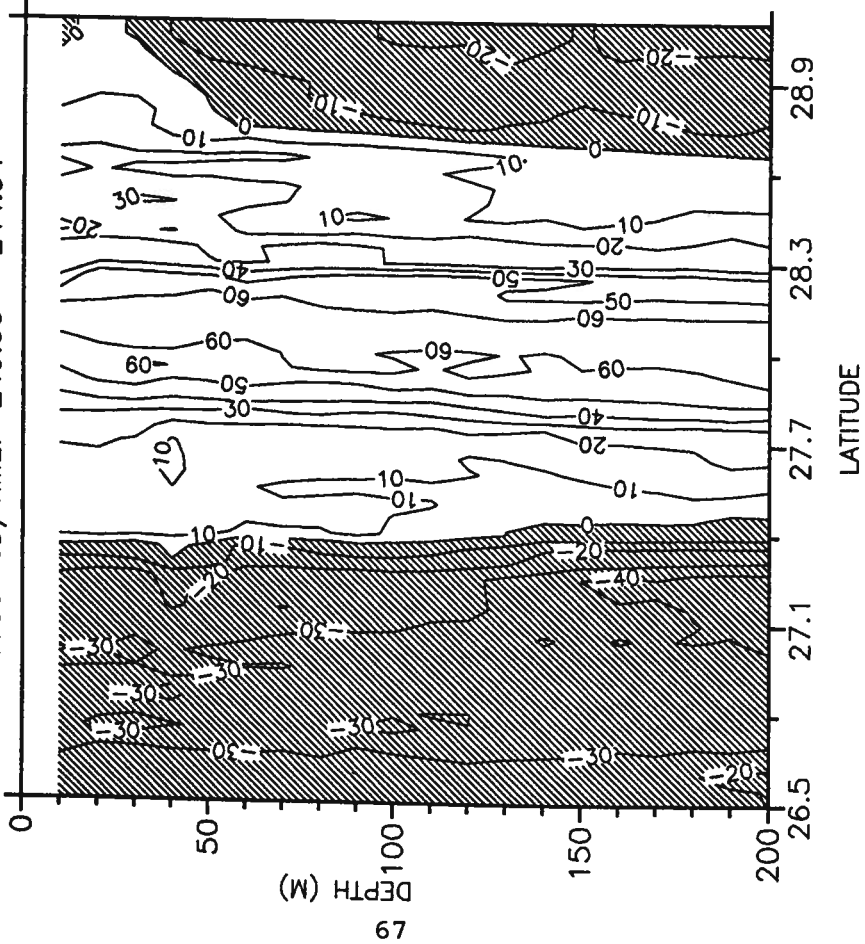

V-VELOCITY SECTION 11 (LORAN)

AUGUST 1985 JD/TIME: 243.38 - 244.94

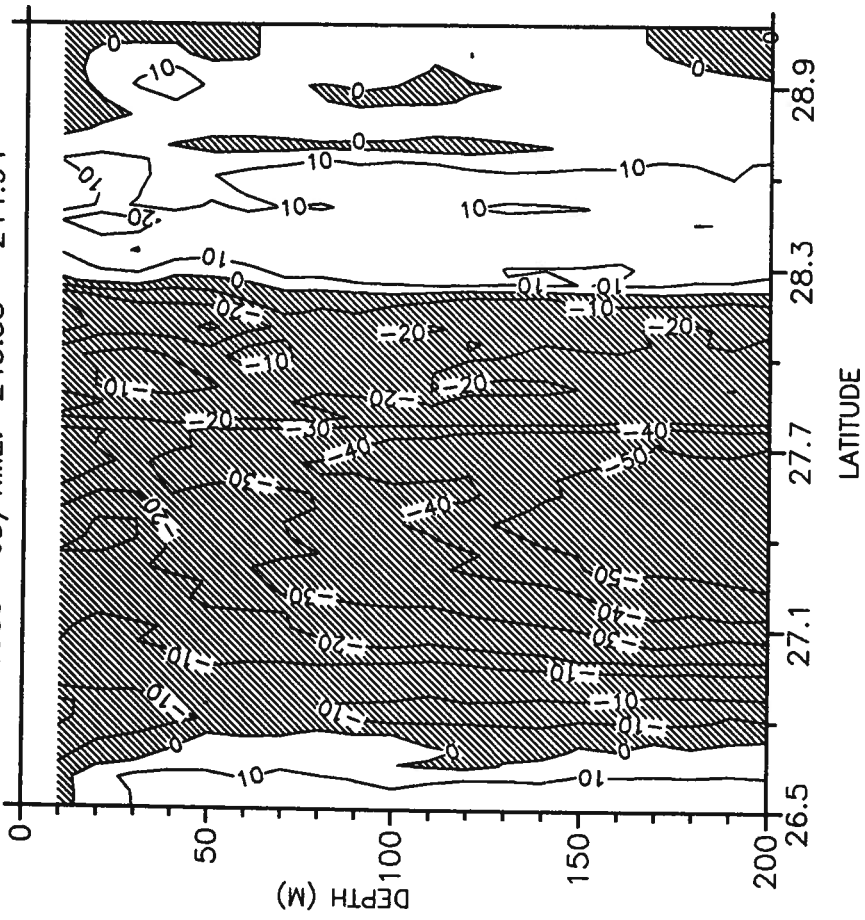

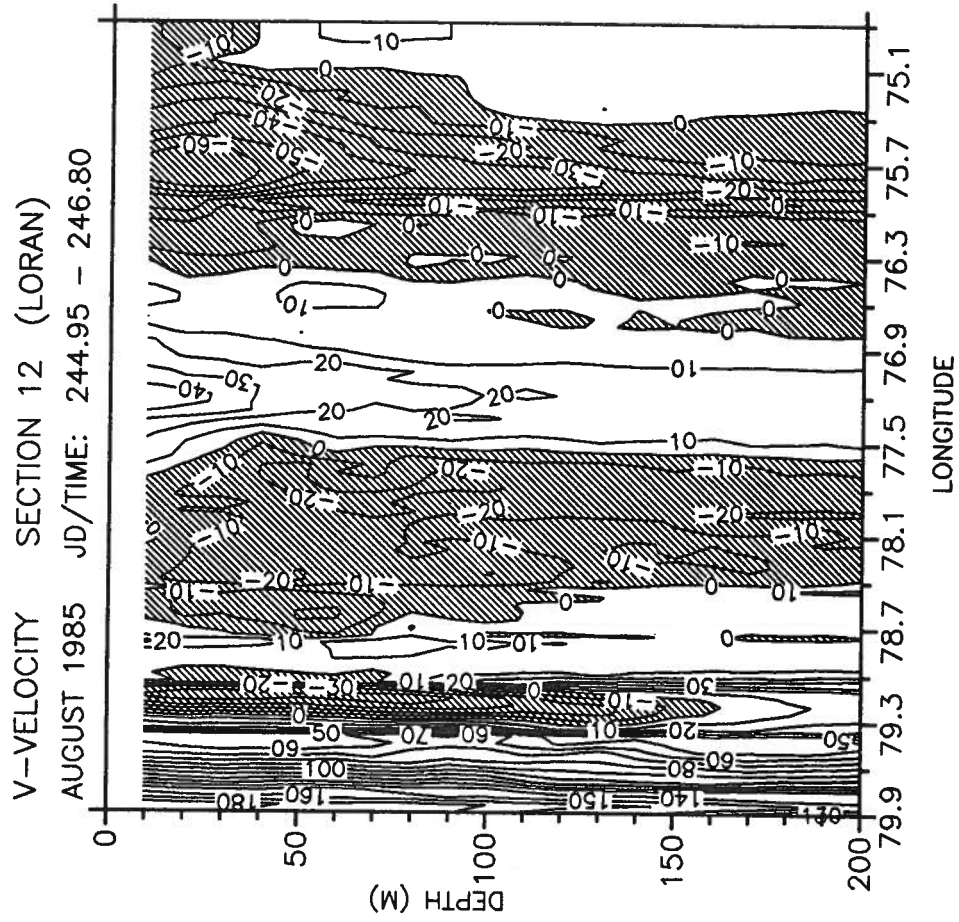
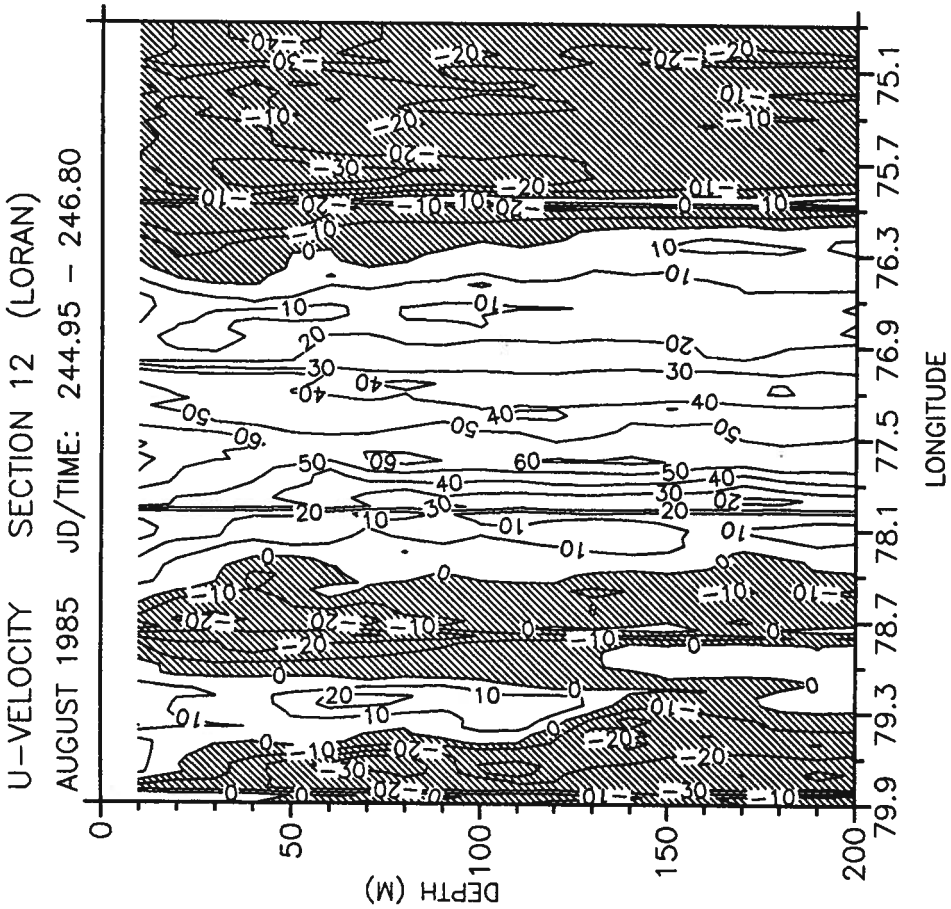

U-VELOCITY SECTION 12 (LORAN)  
 AUGUST 1985 JD/TIME: 246.81 - 247.54

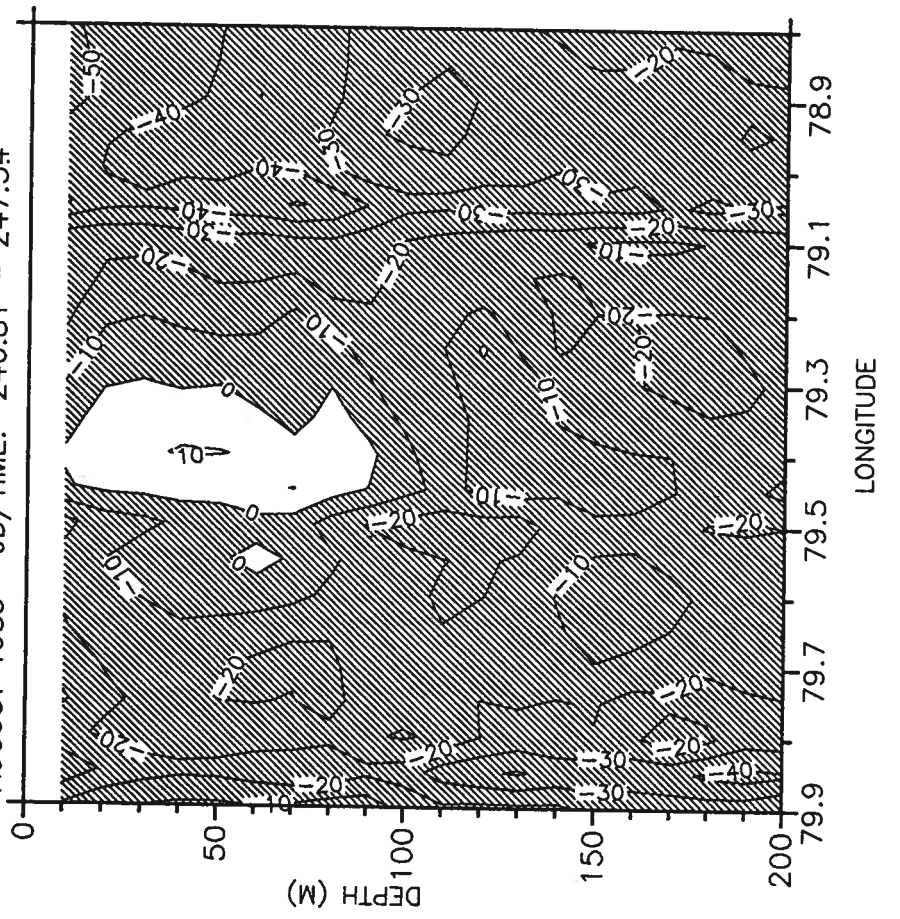

V-VELOCITY SECTION 12 (LORAN)  
 AUGUST 1985 JD/TIME: 246.81 - 247.54

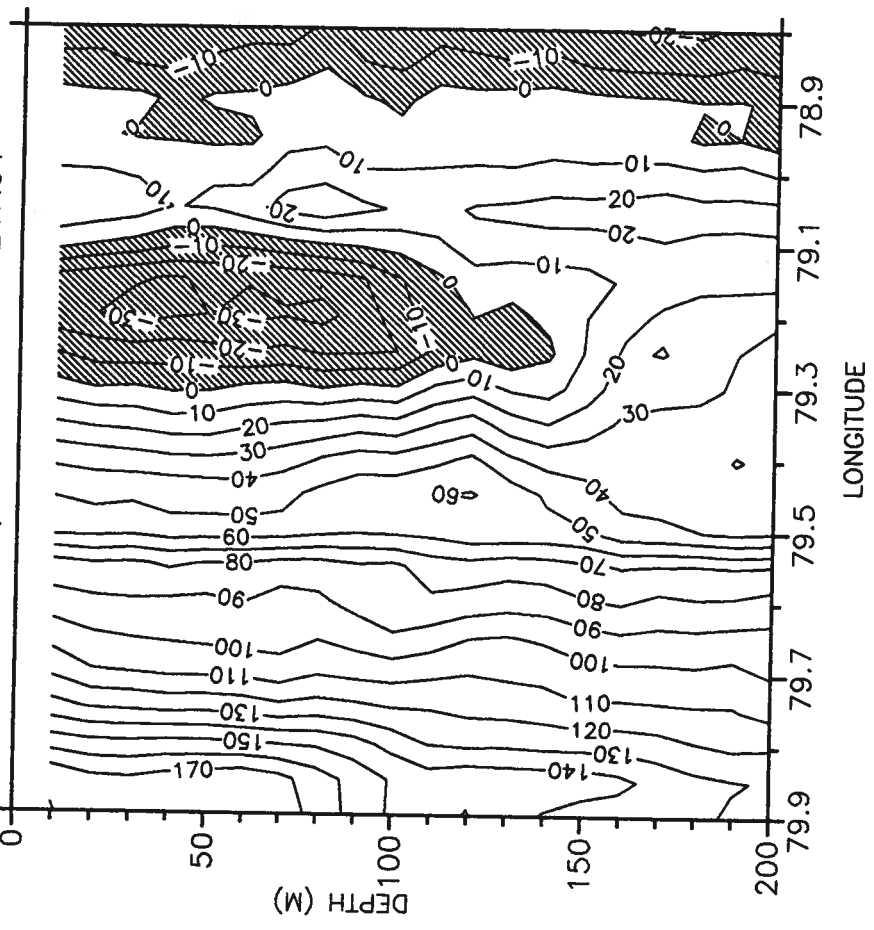



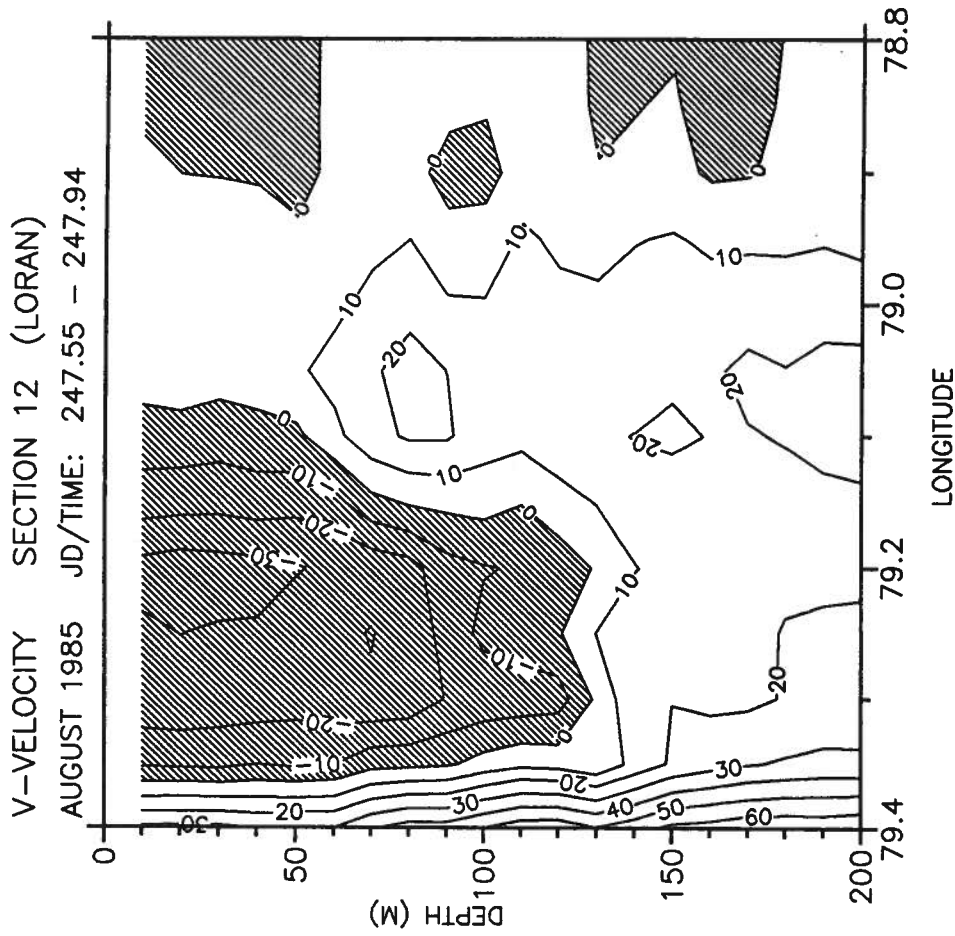
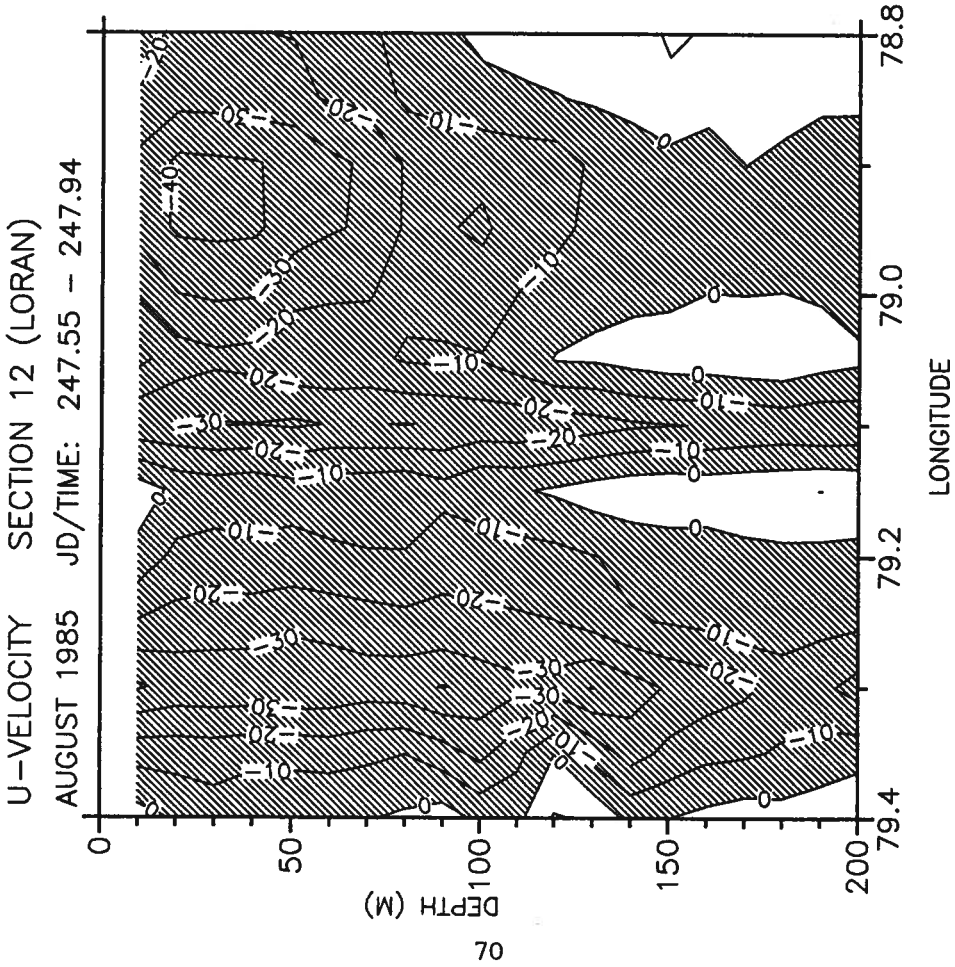

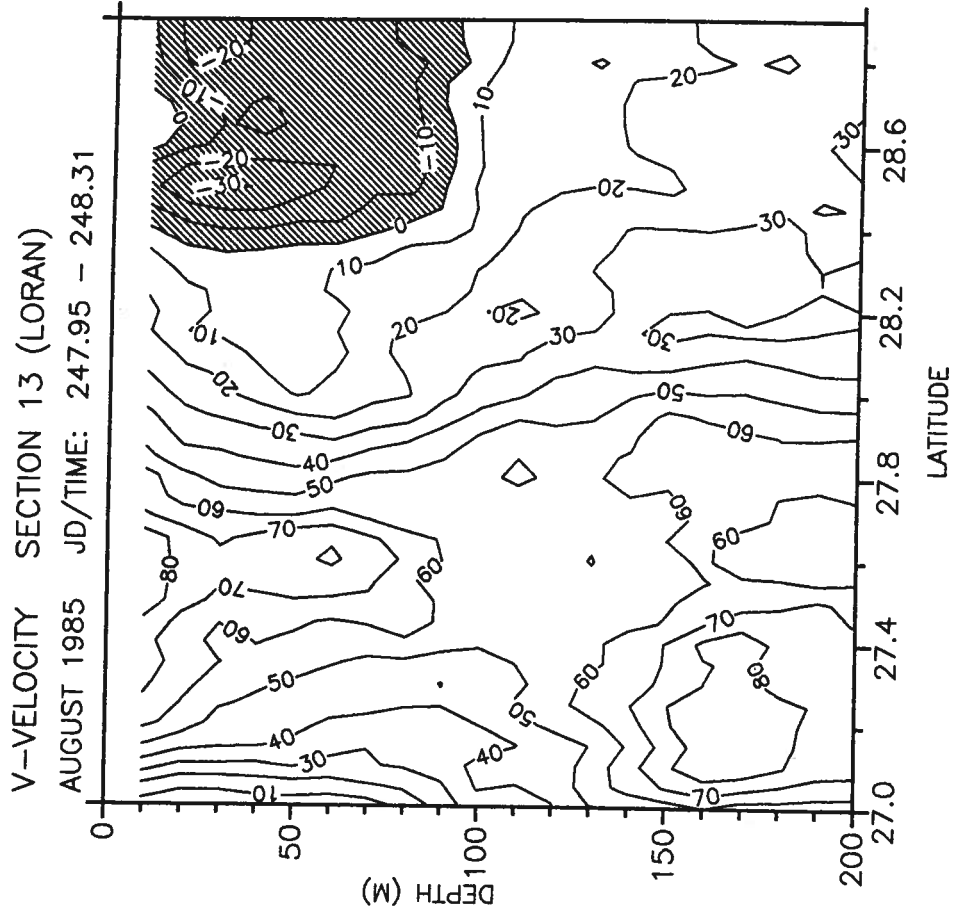
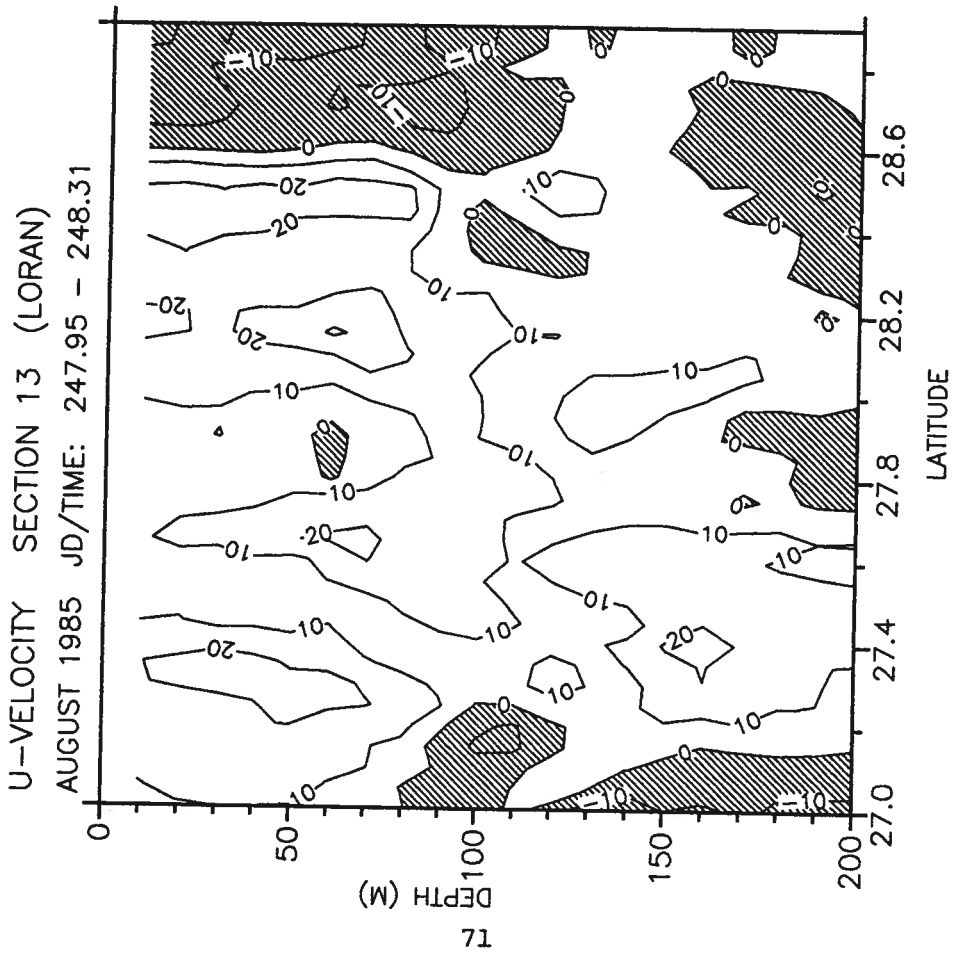

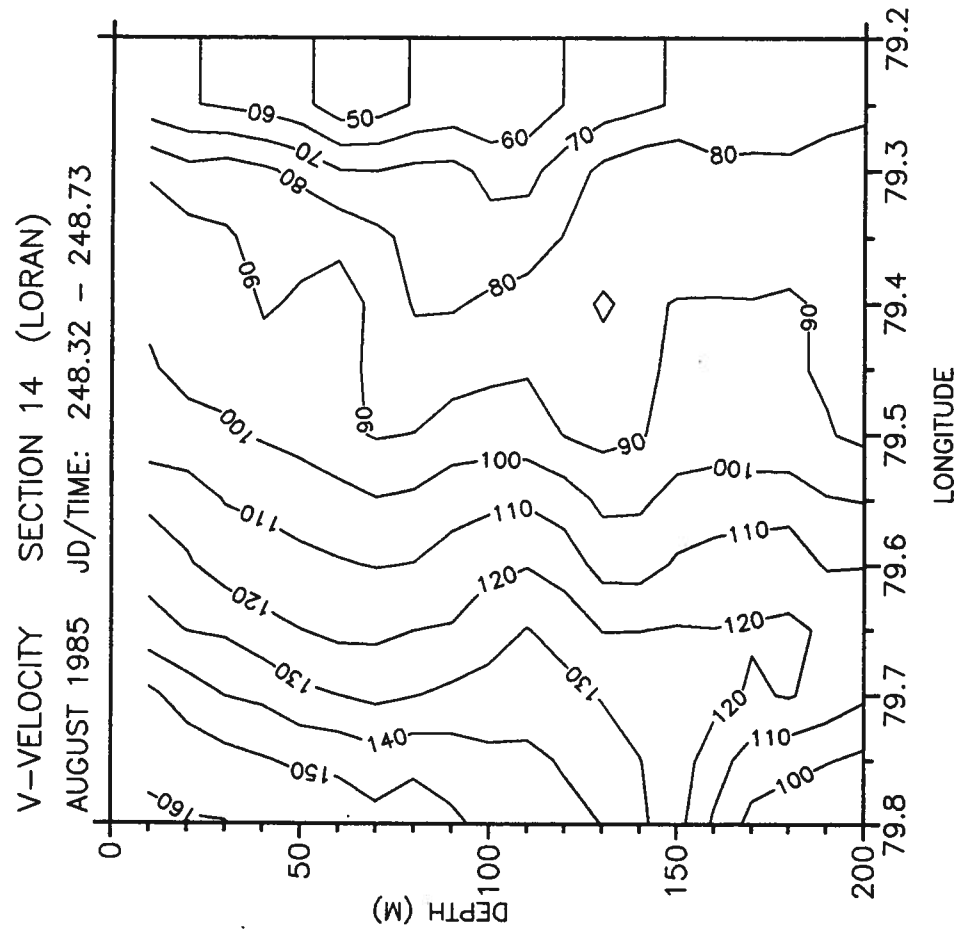
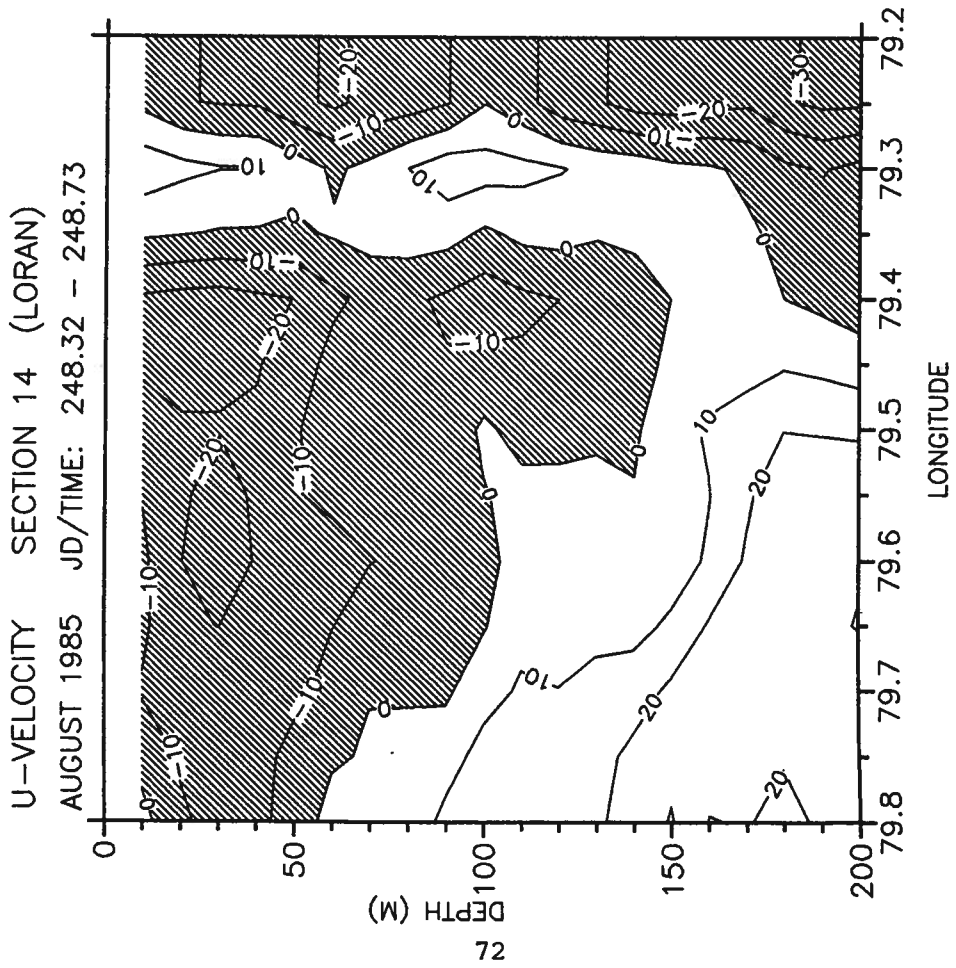

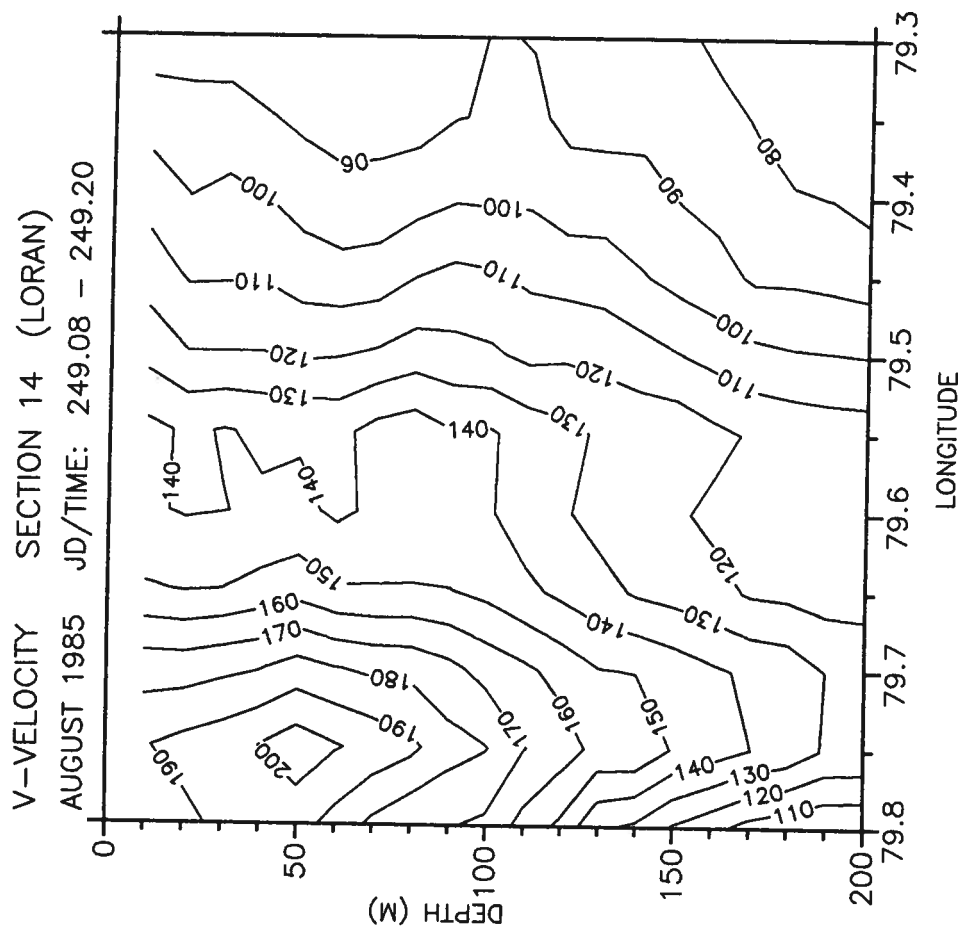
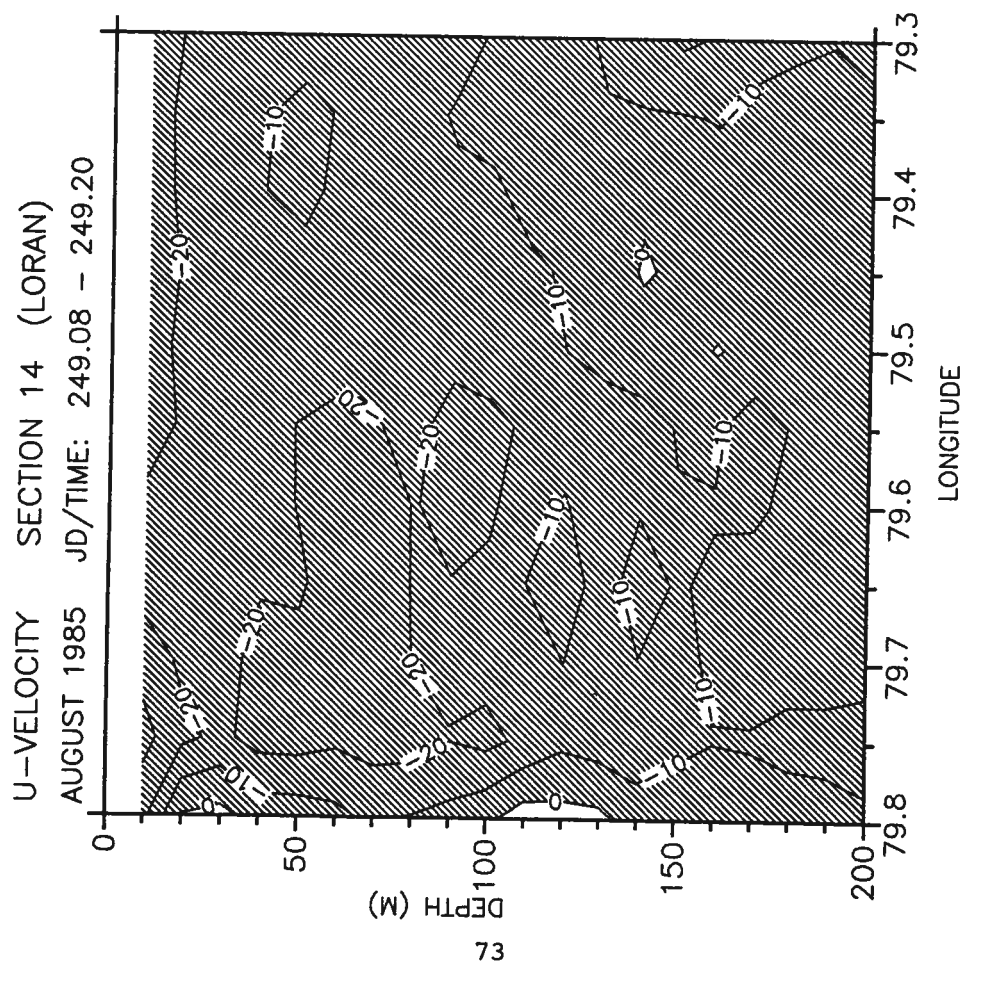

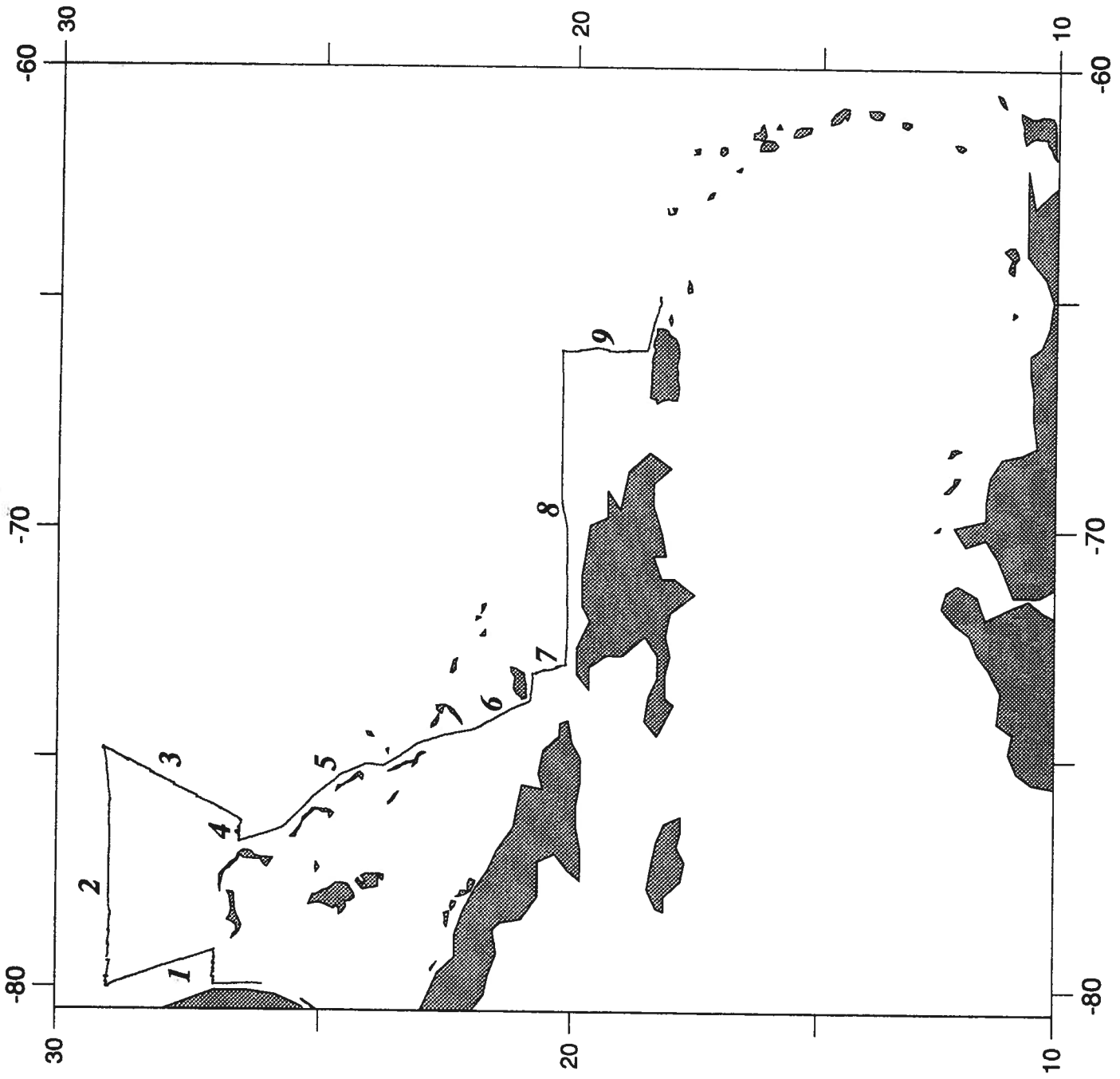

*Map of the Ametek-Straza (ADCP) trackline - January 1986 (Leg I)*

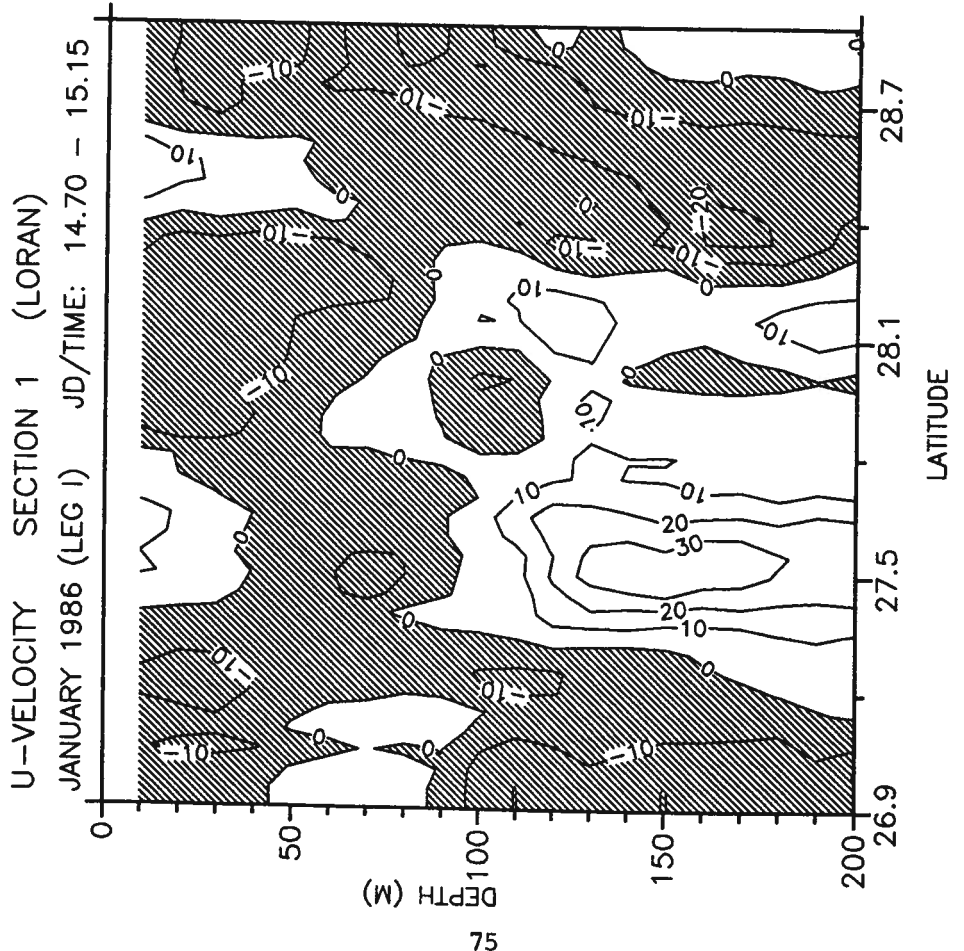
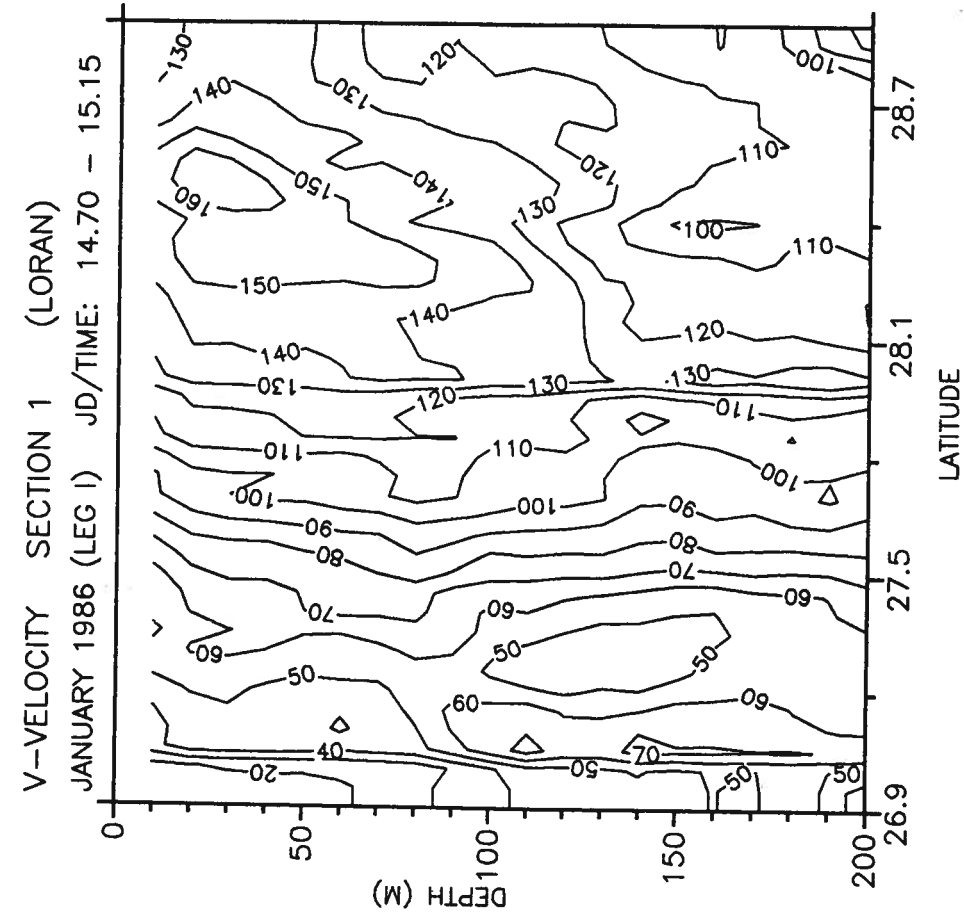

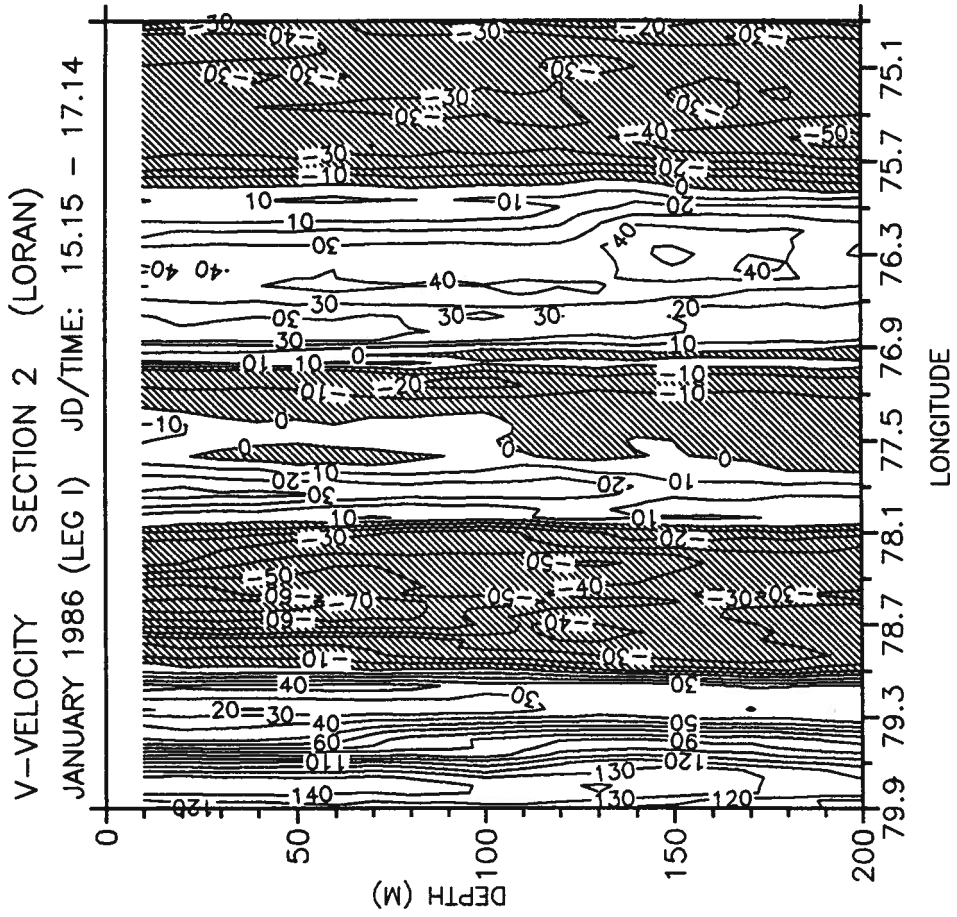
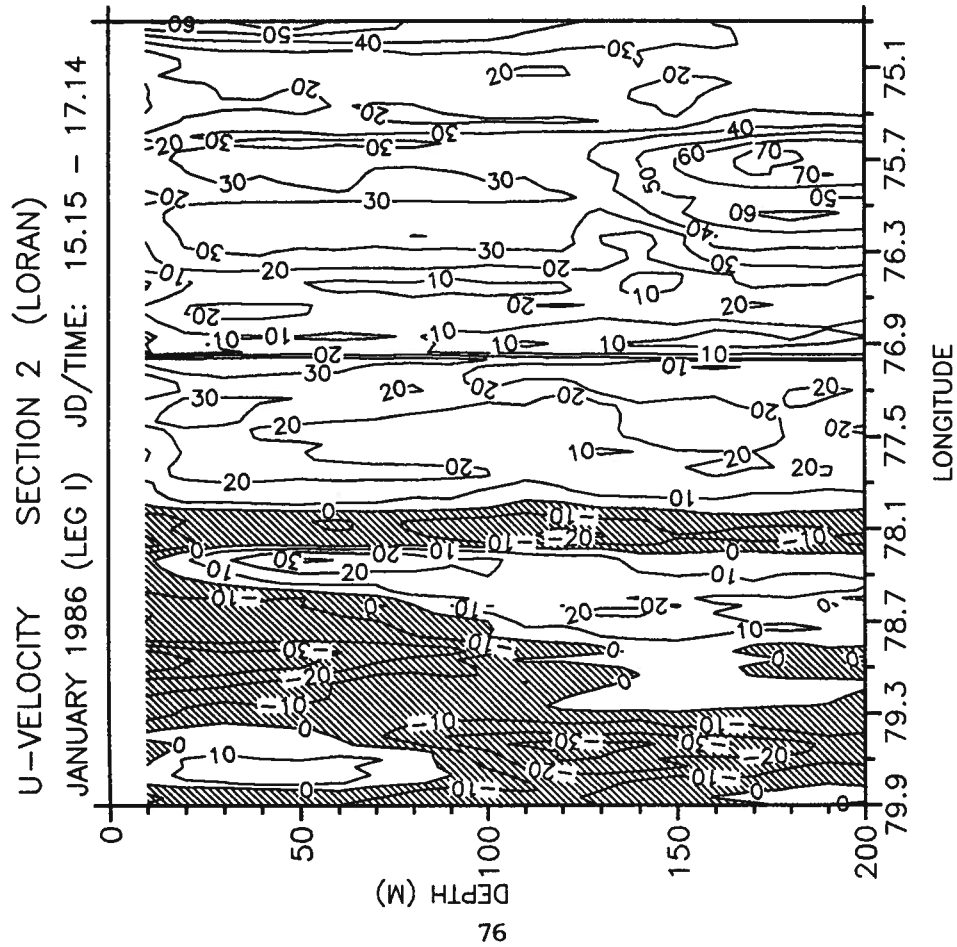

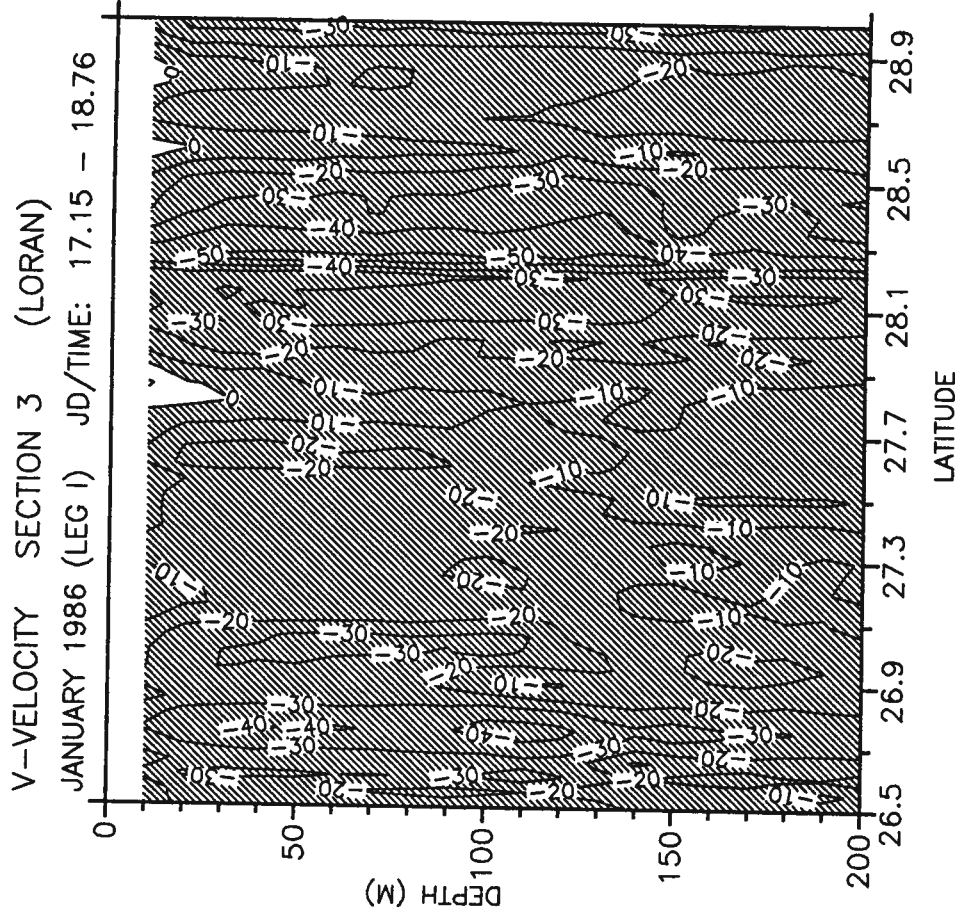
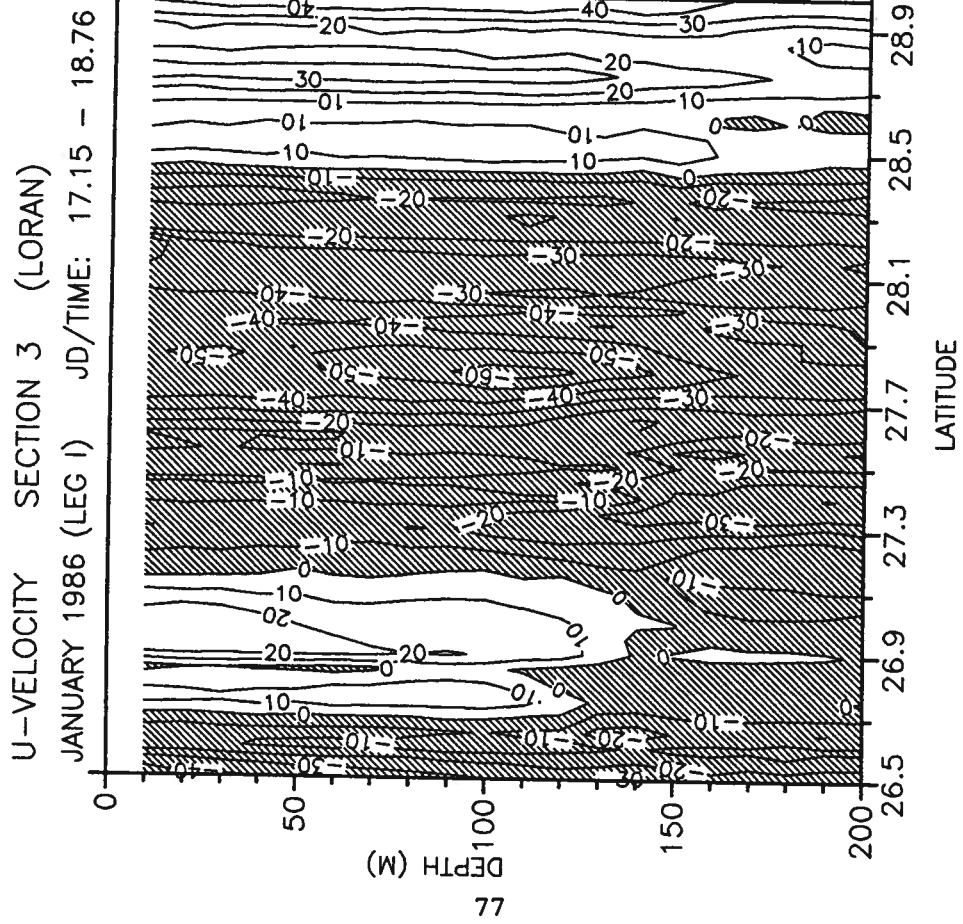



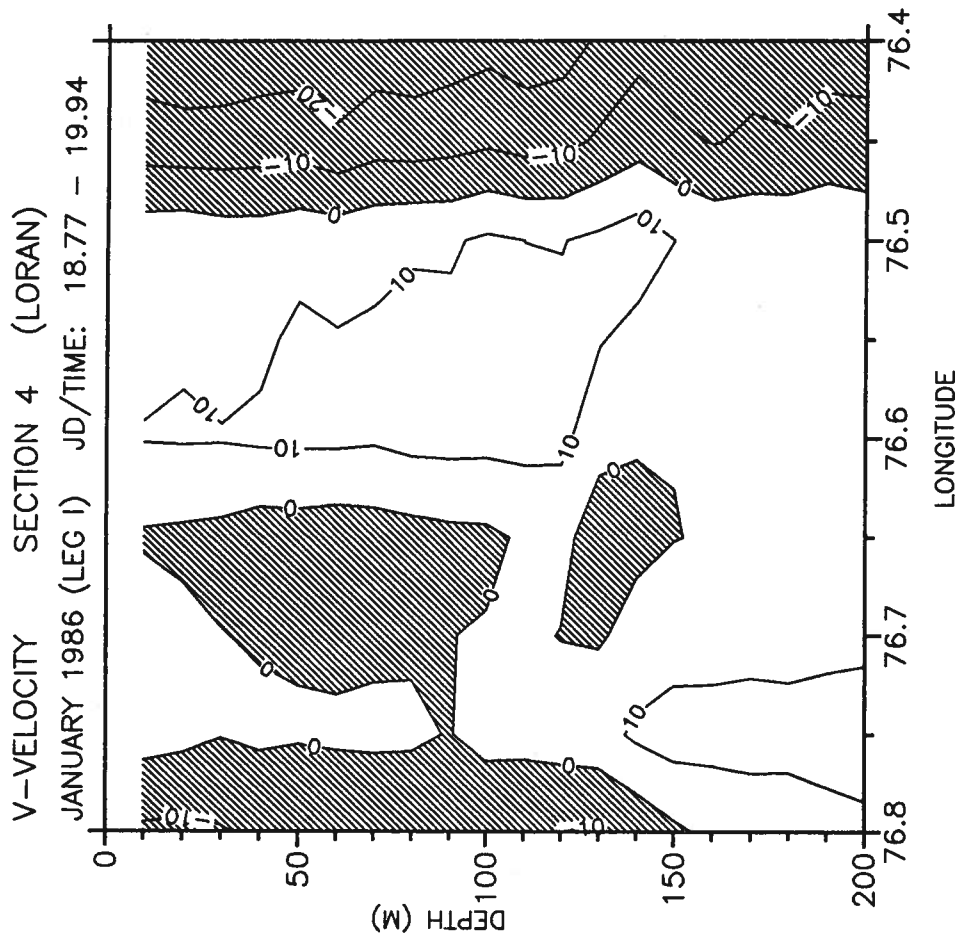
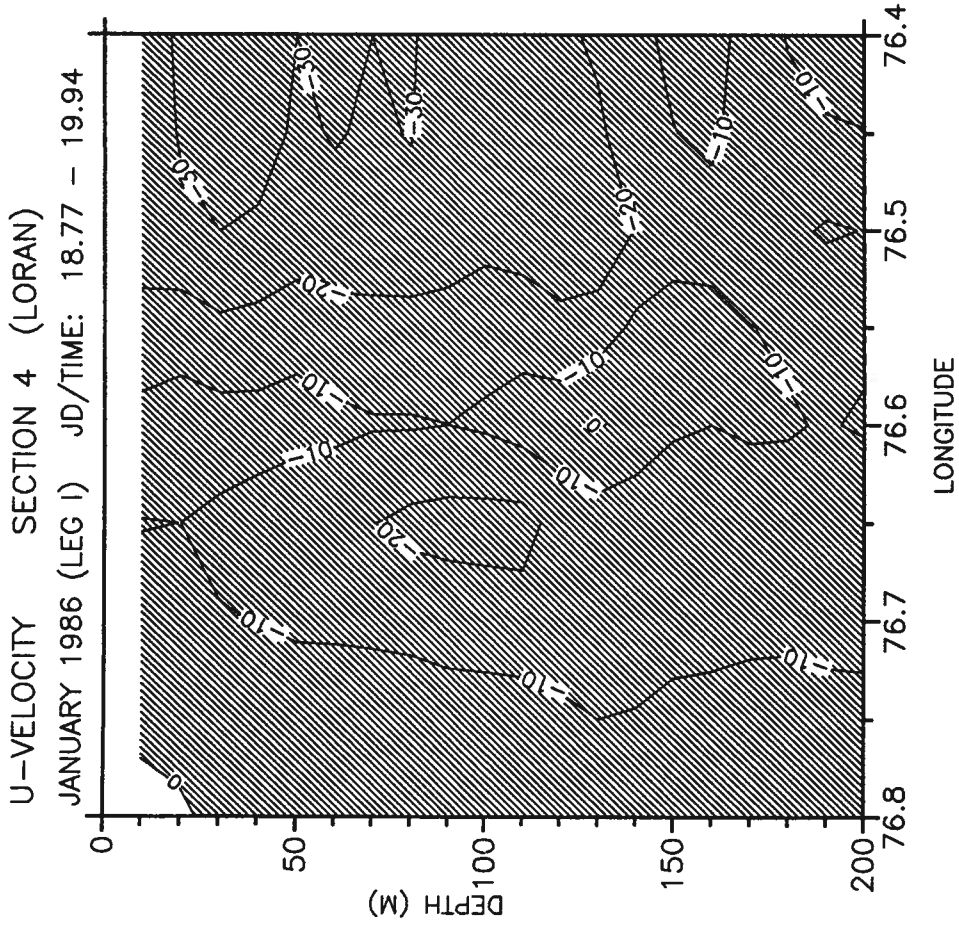

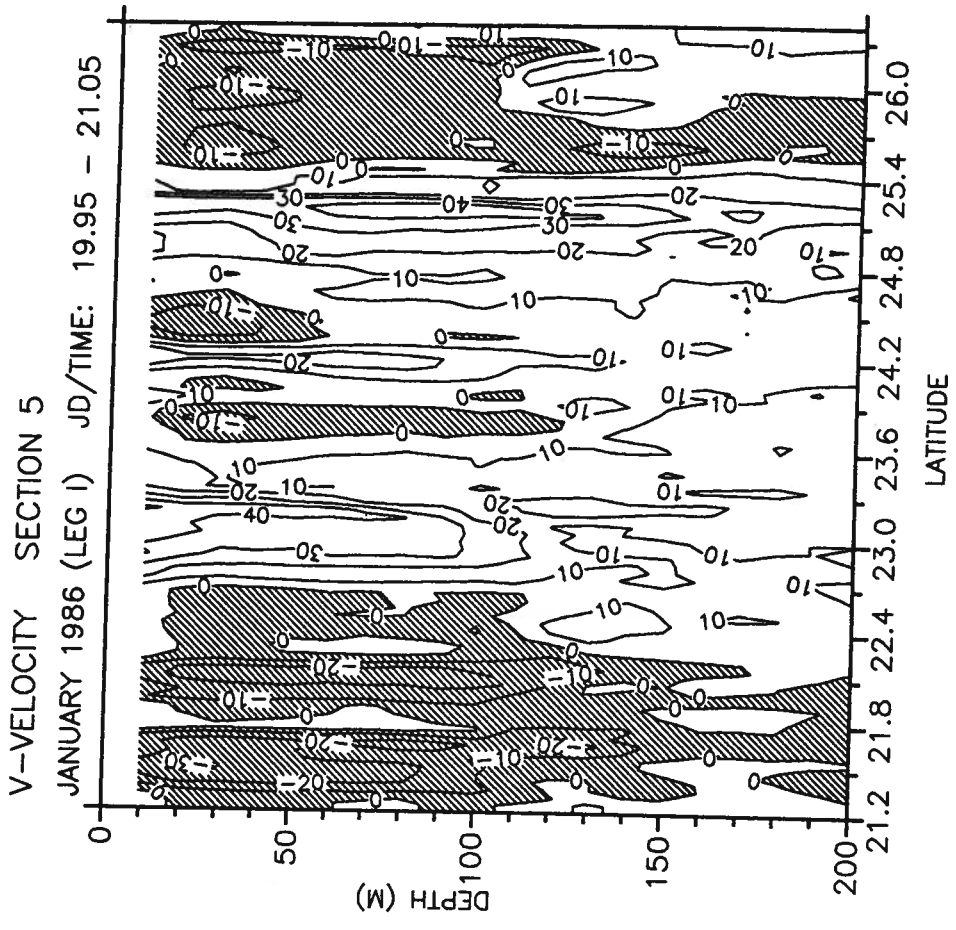
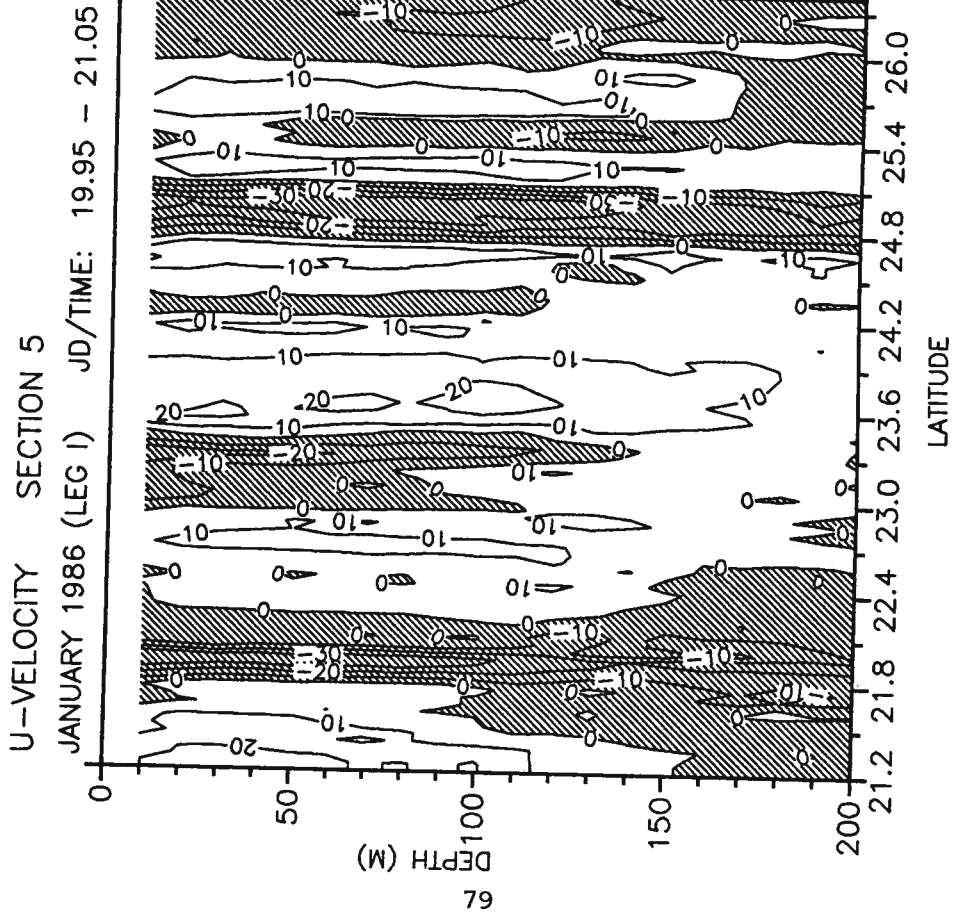

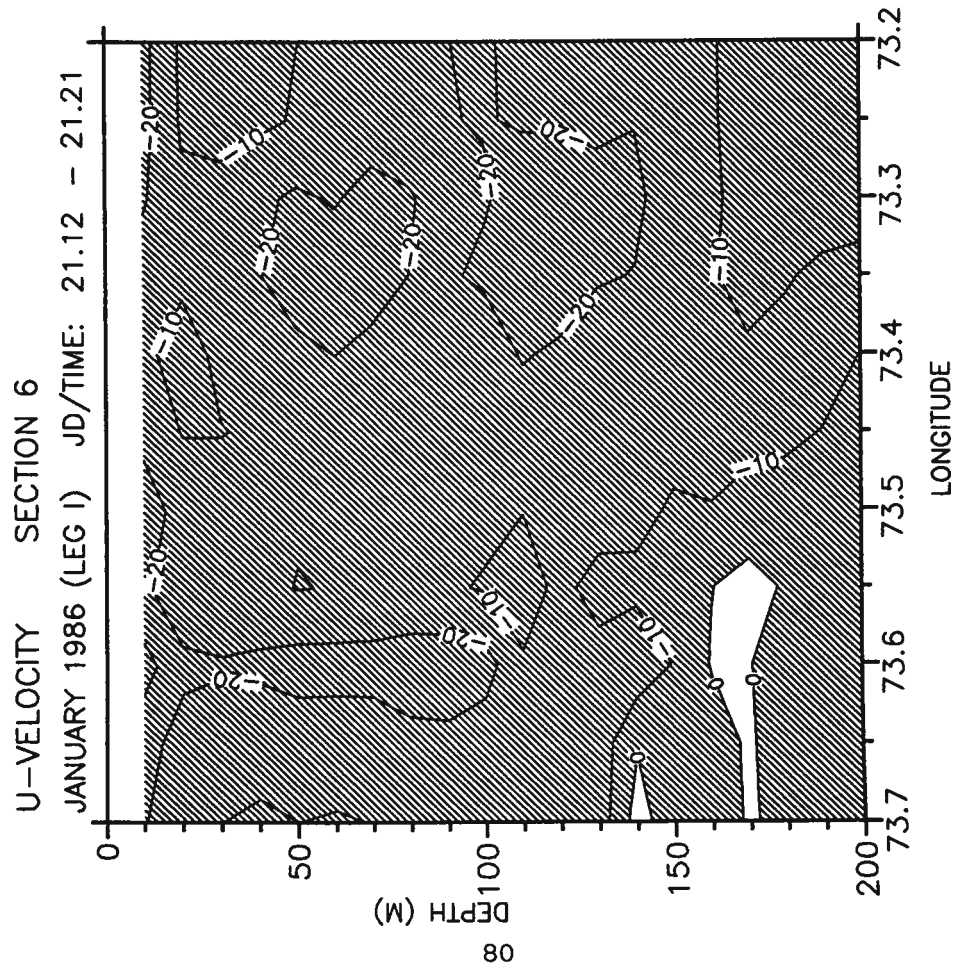
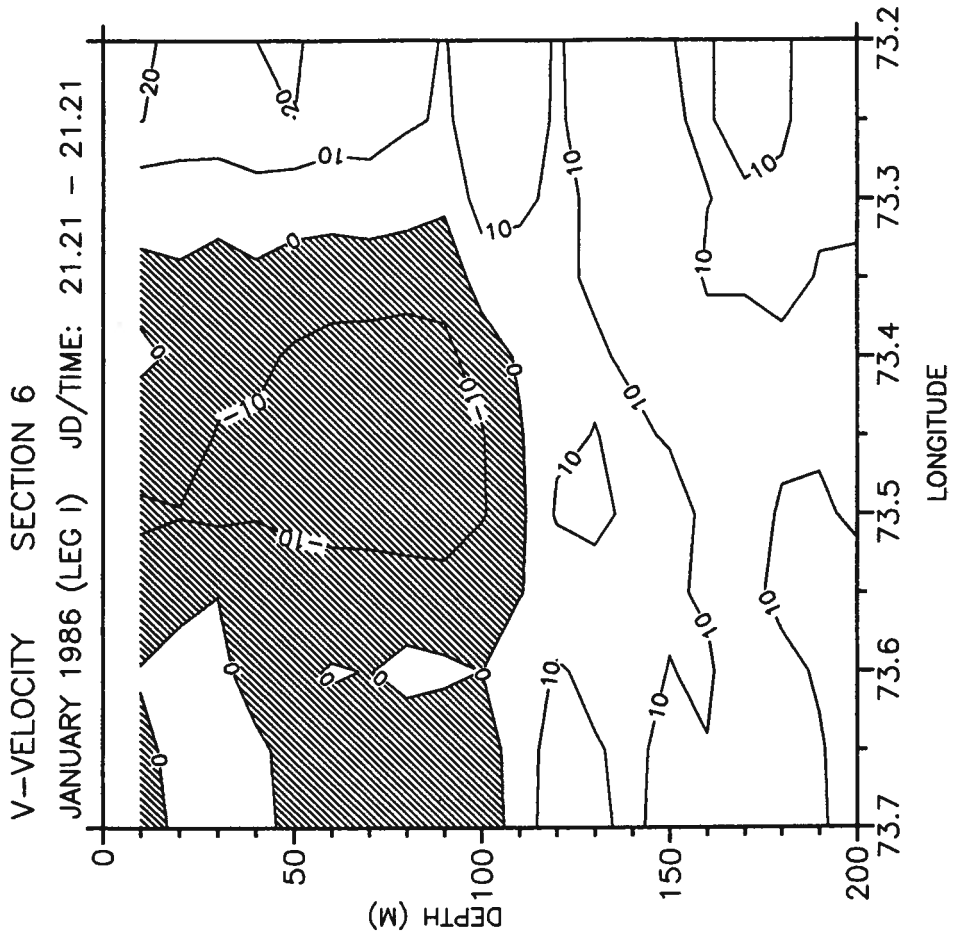

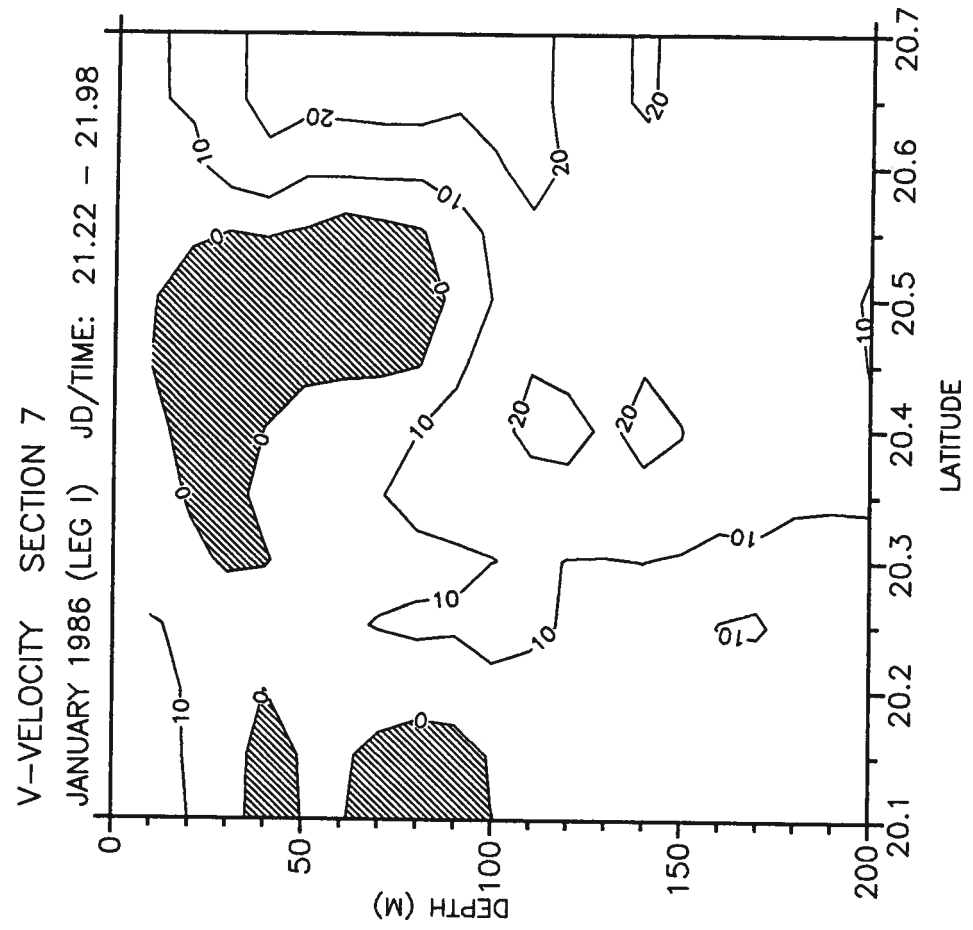
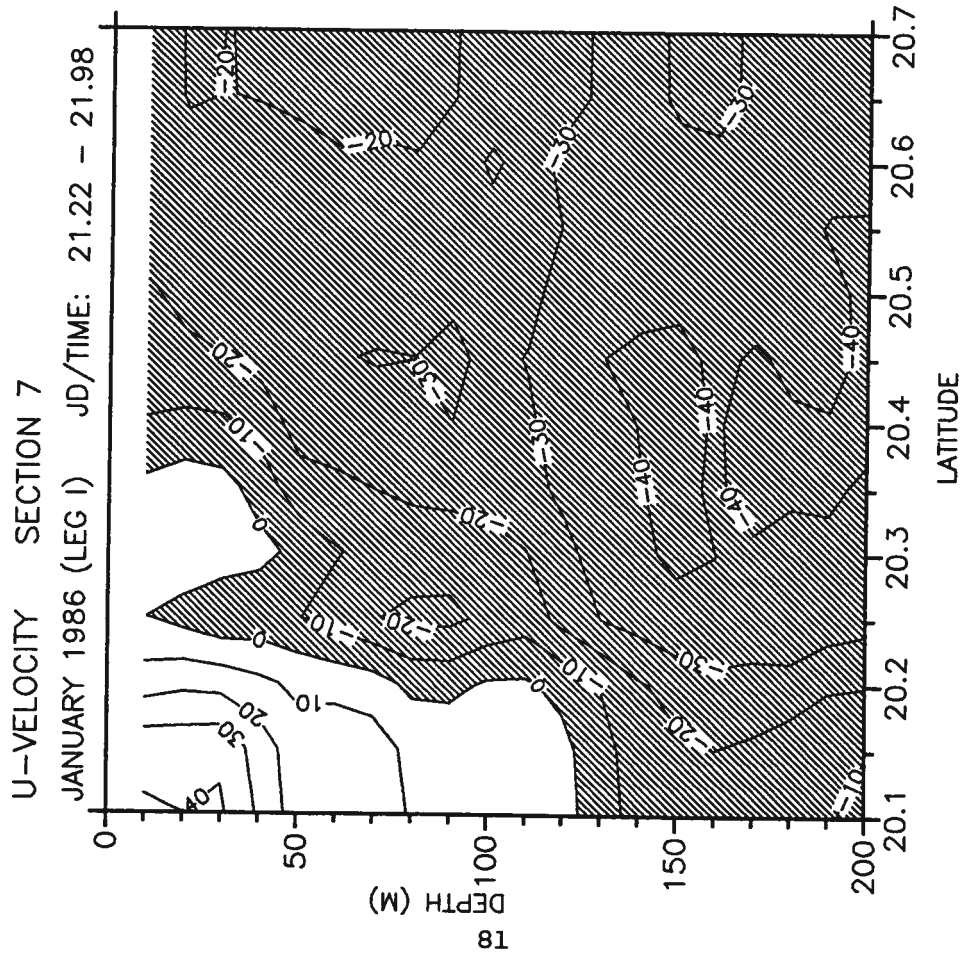

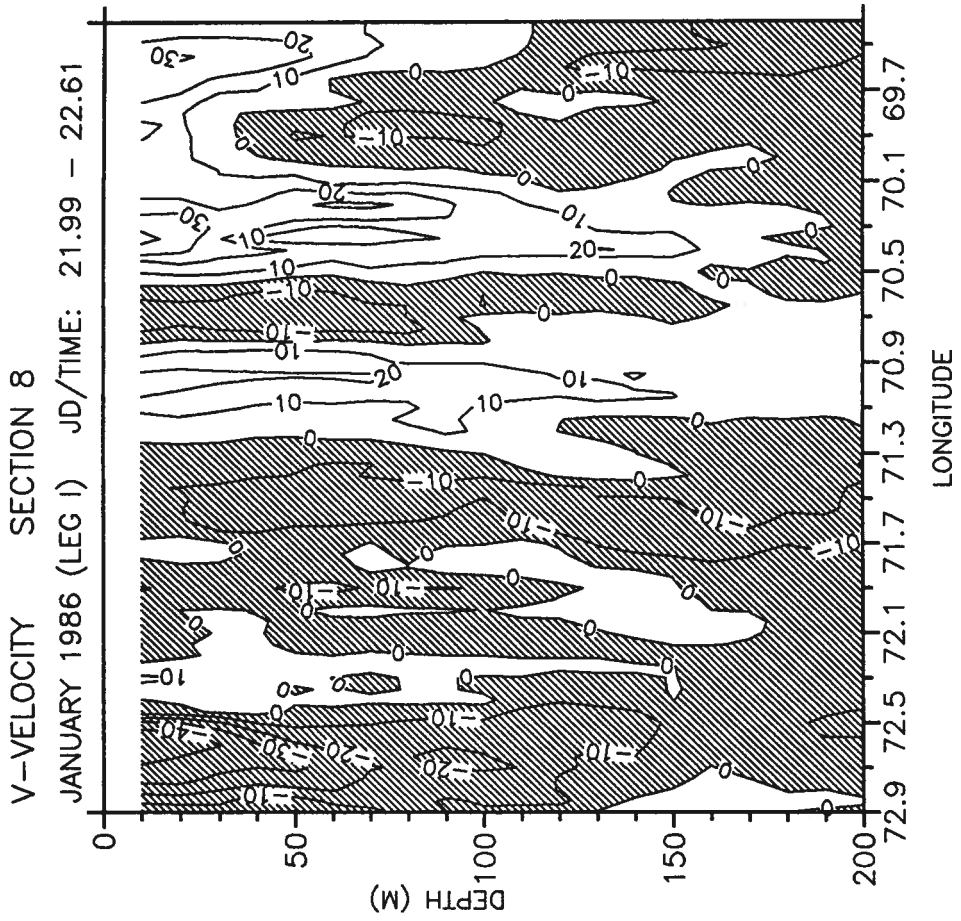
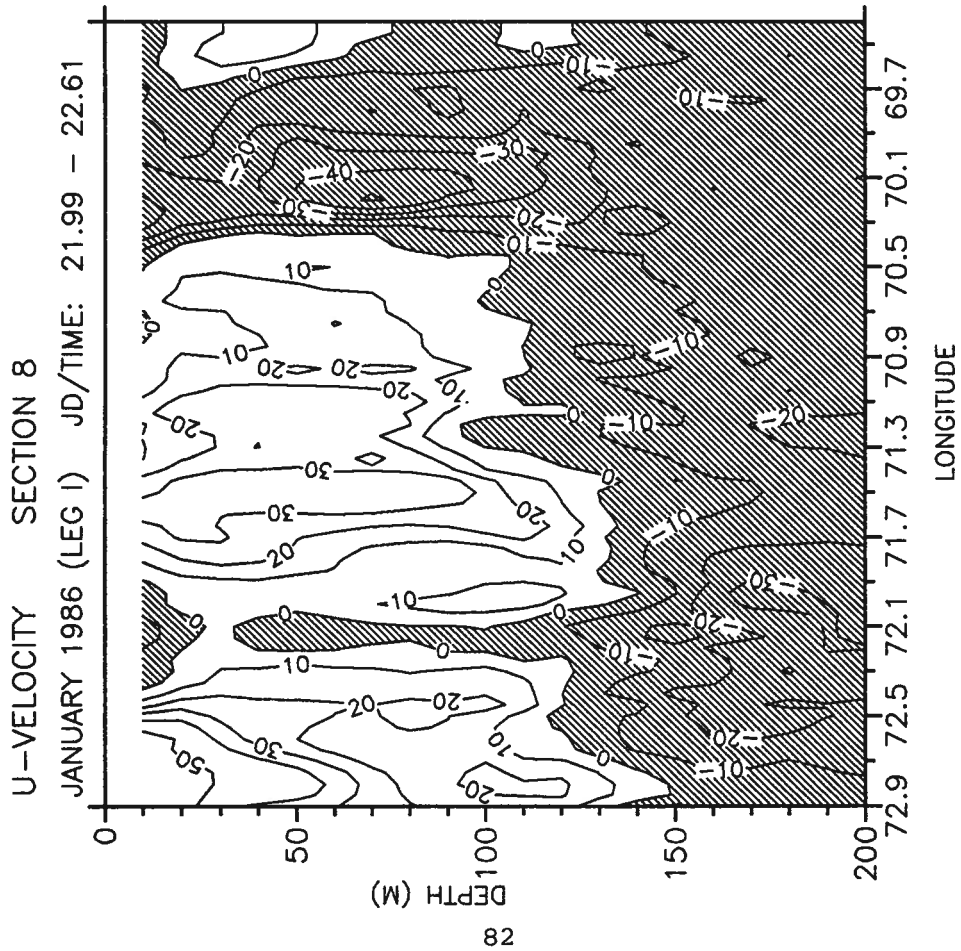

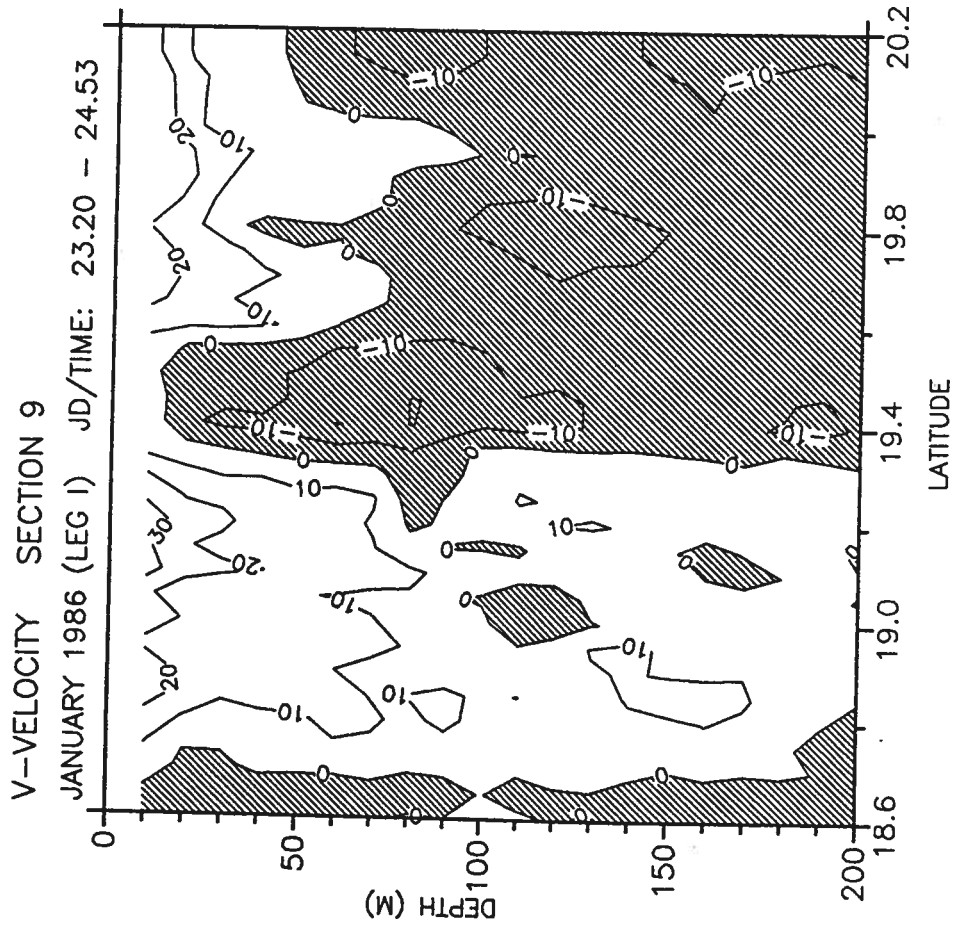
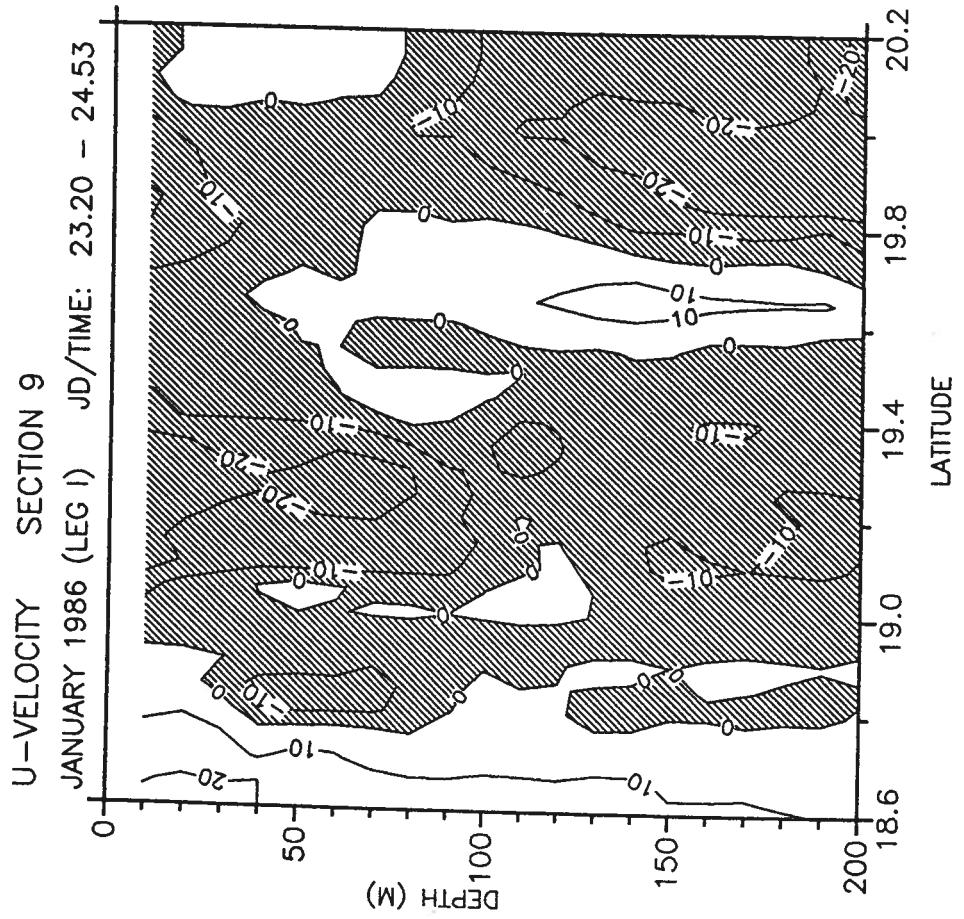

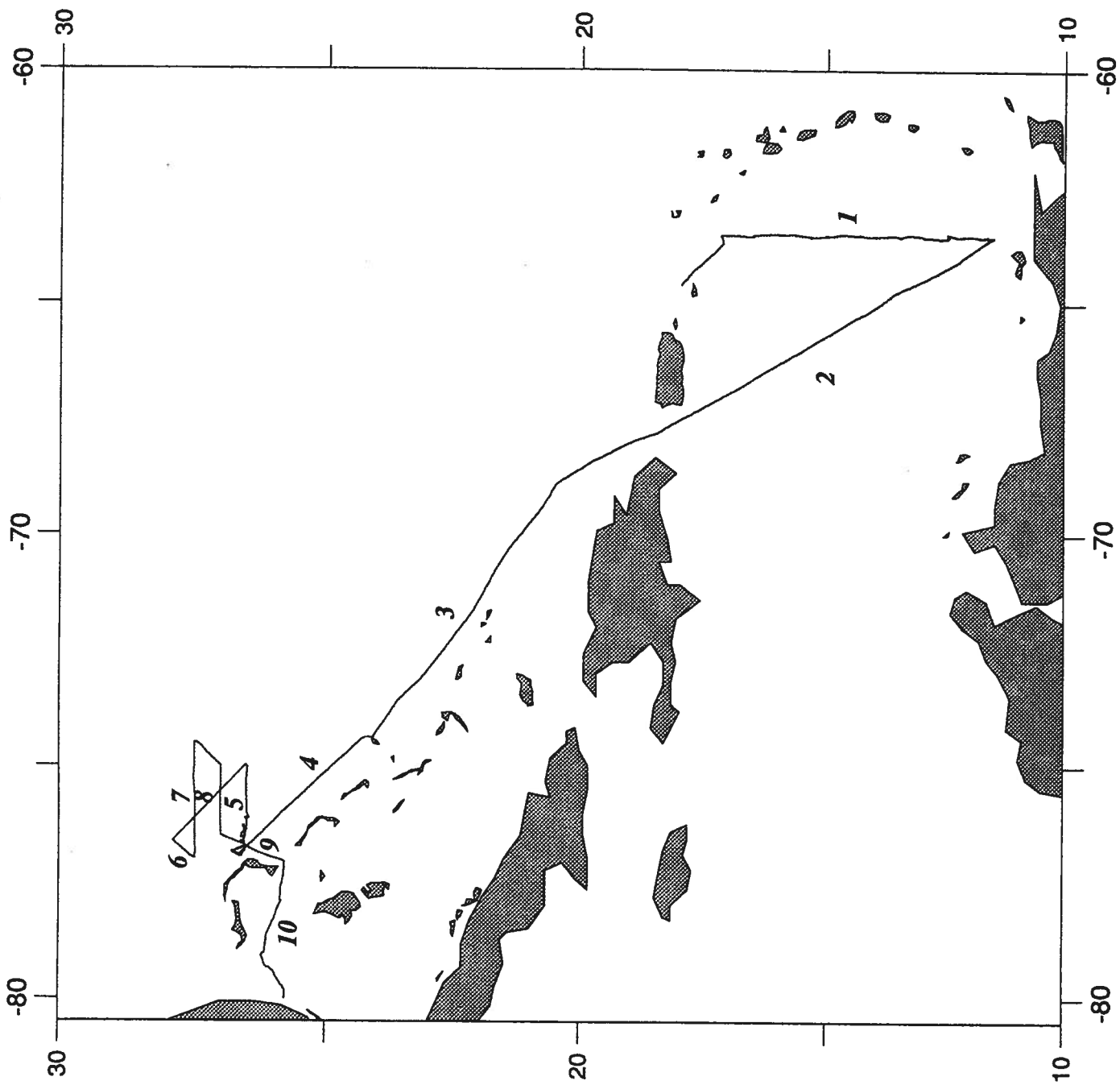

*Map of the Ametek-Straza (ADCP) trackline - January 1986 (Leg II)*

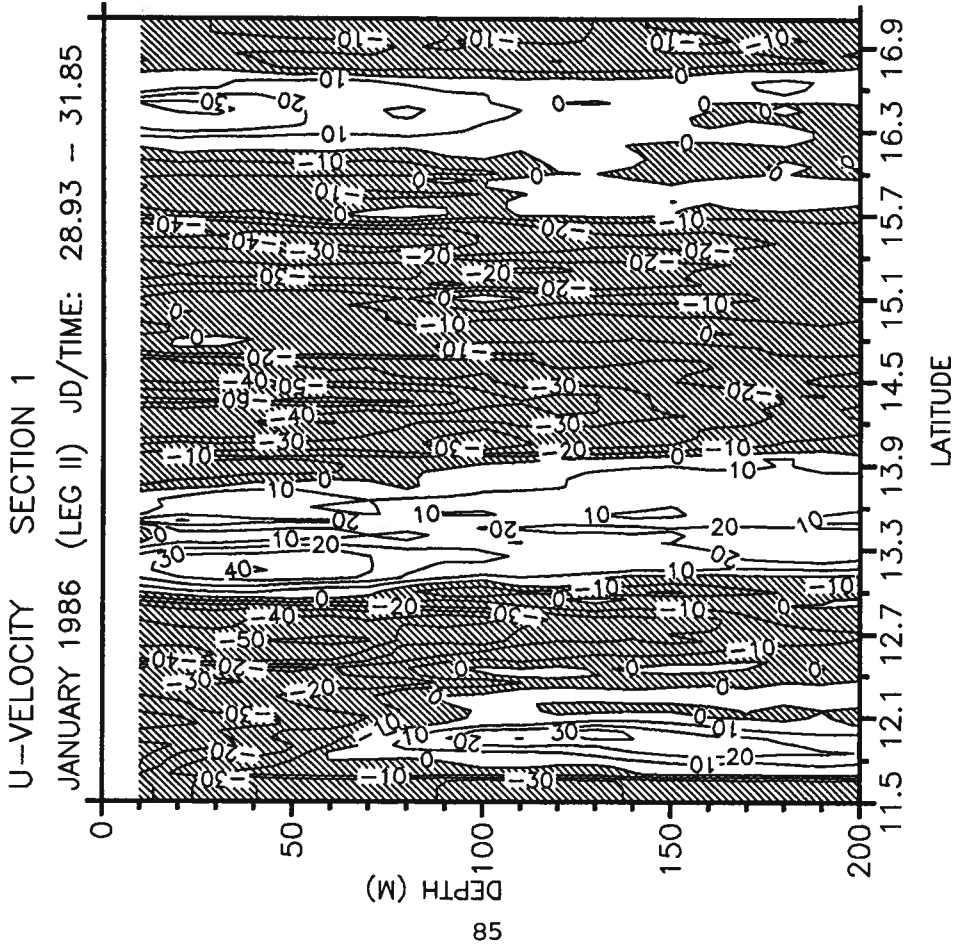
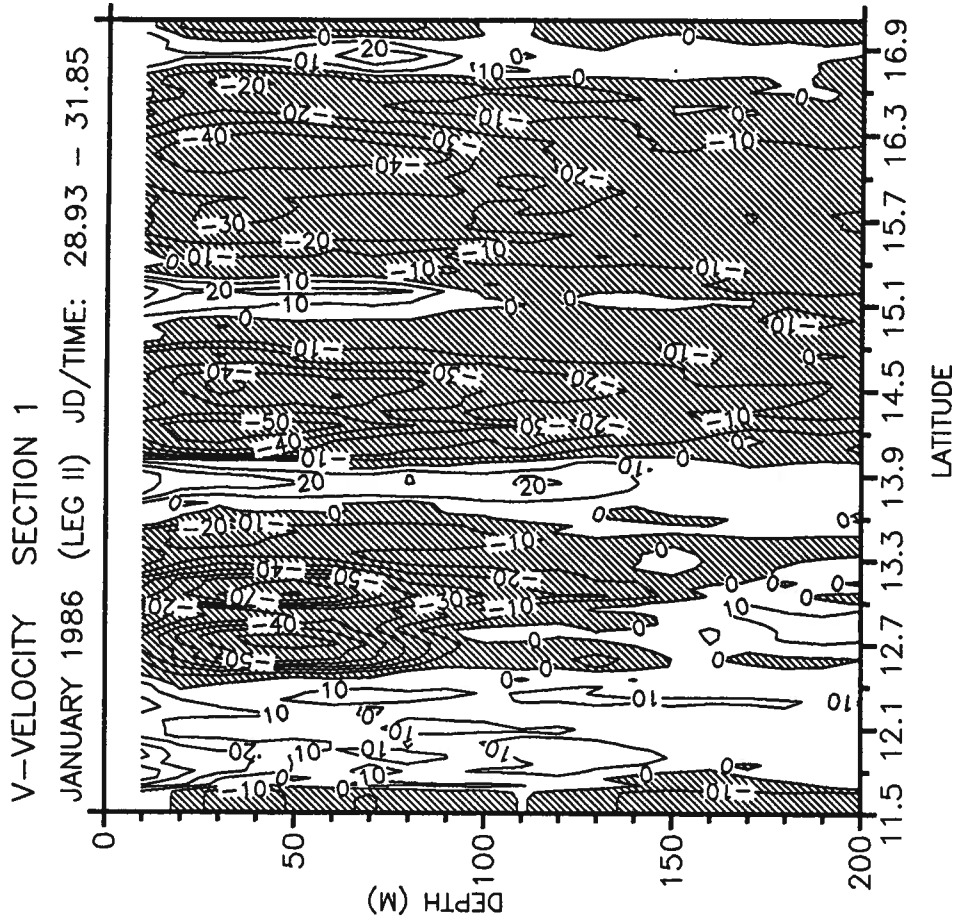



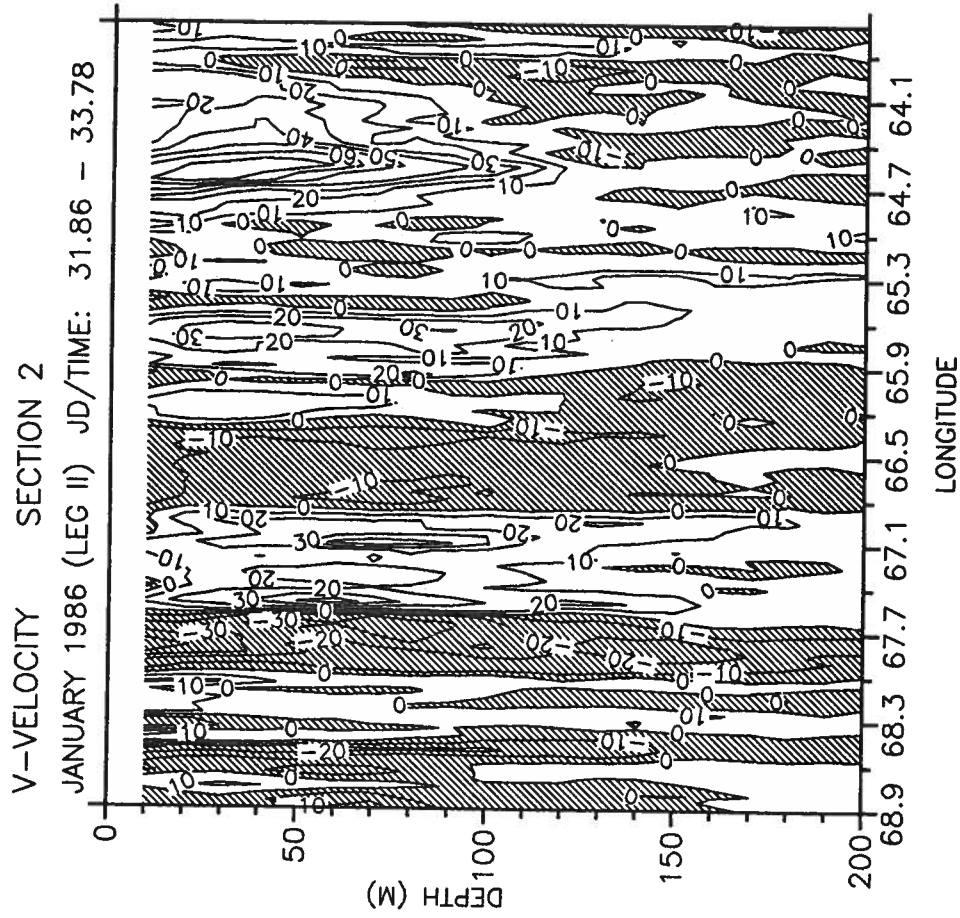
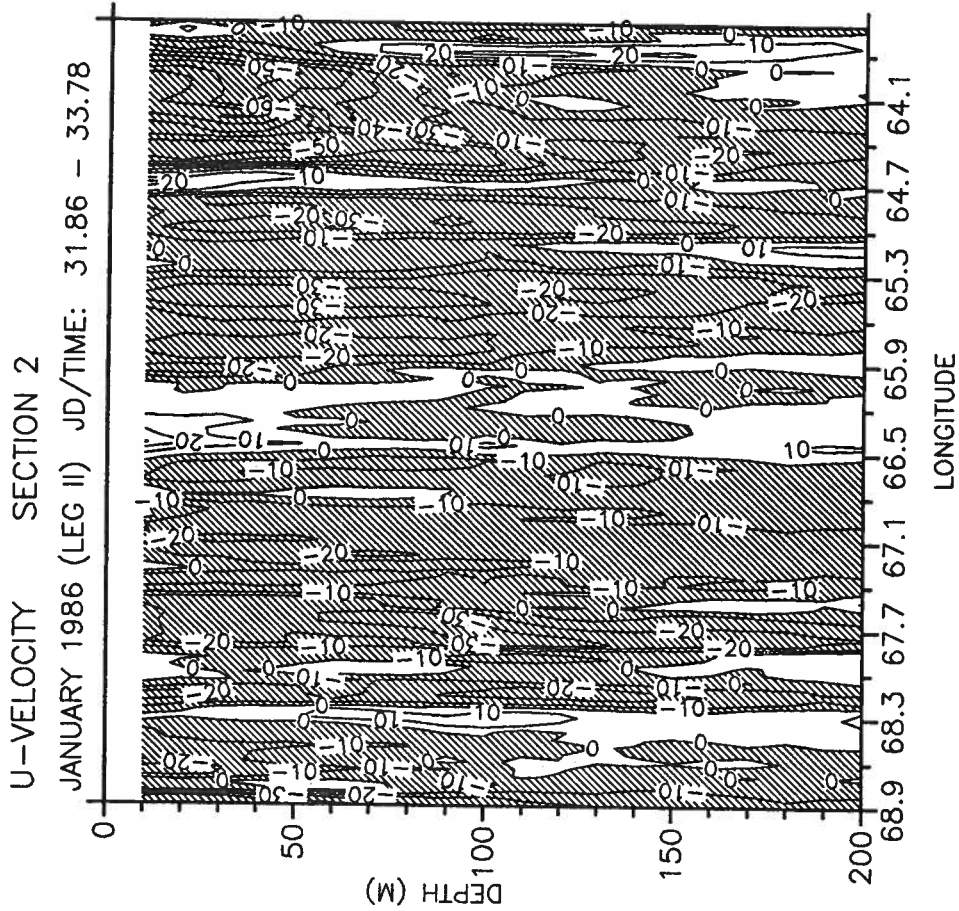

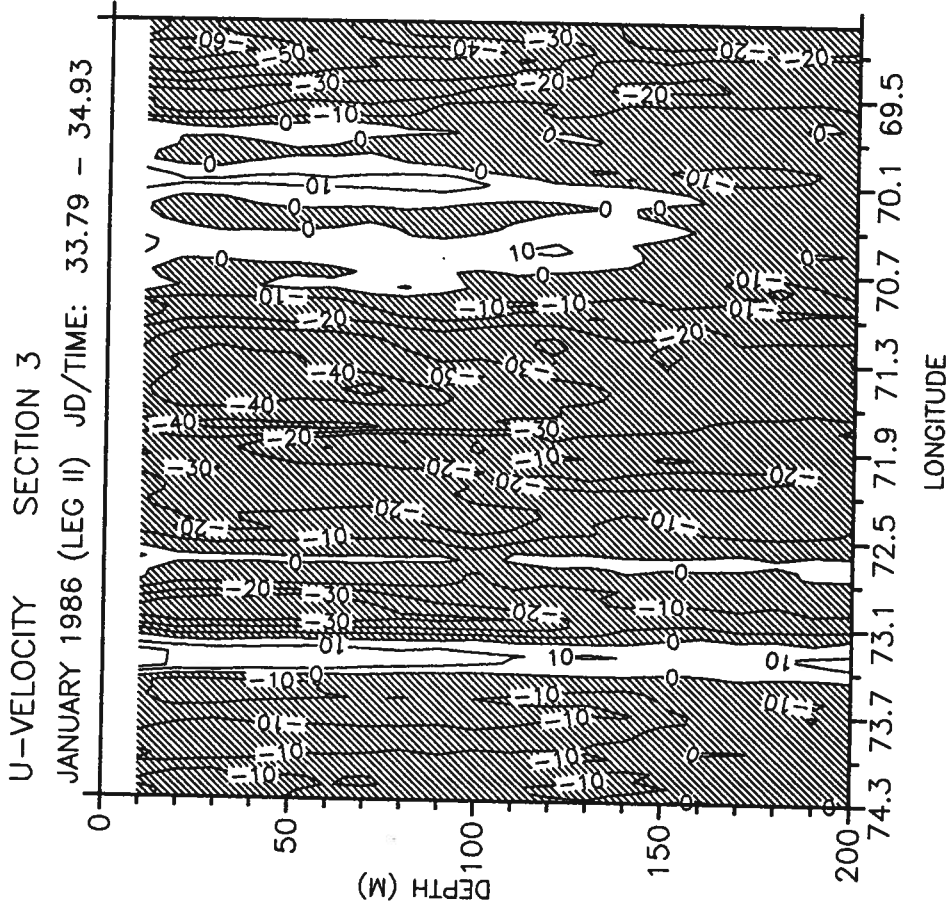
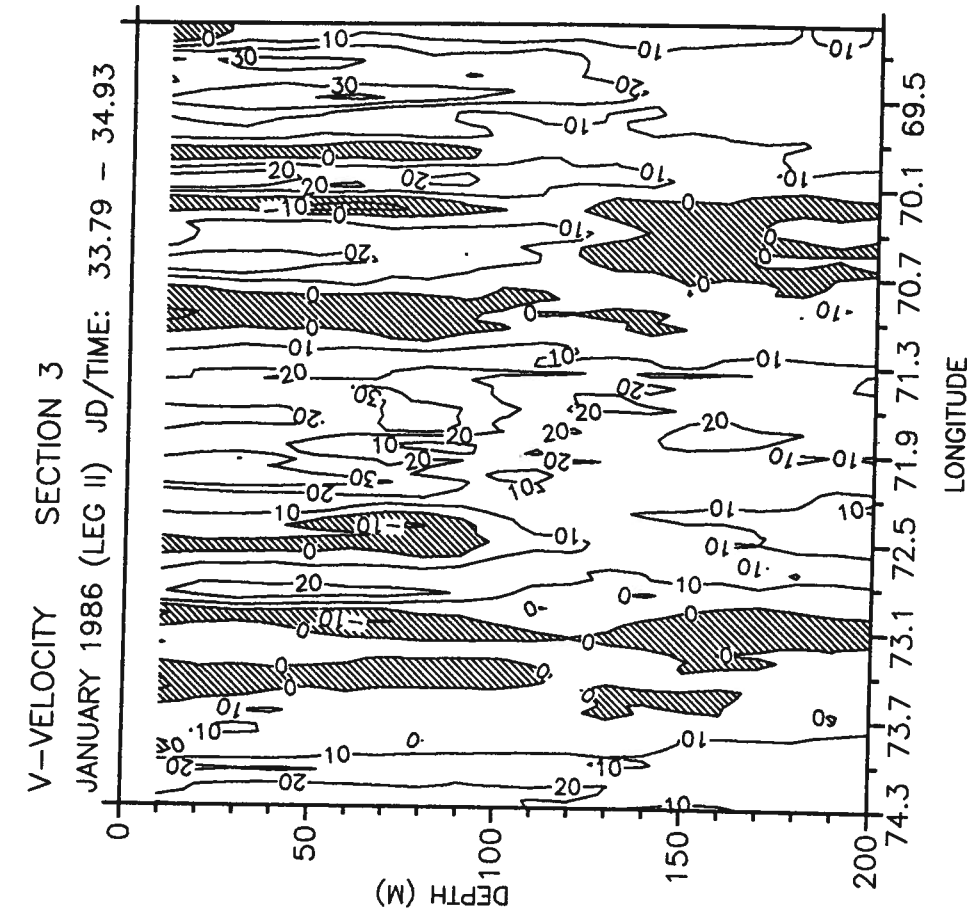

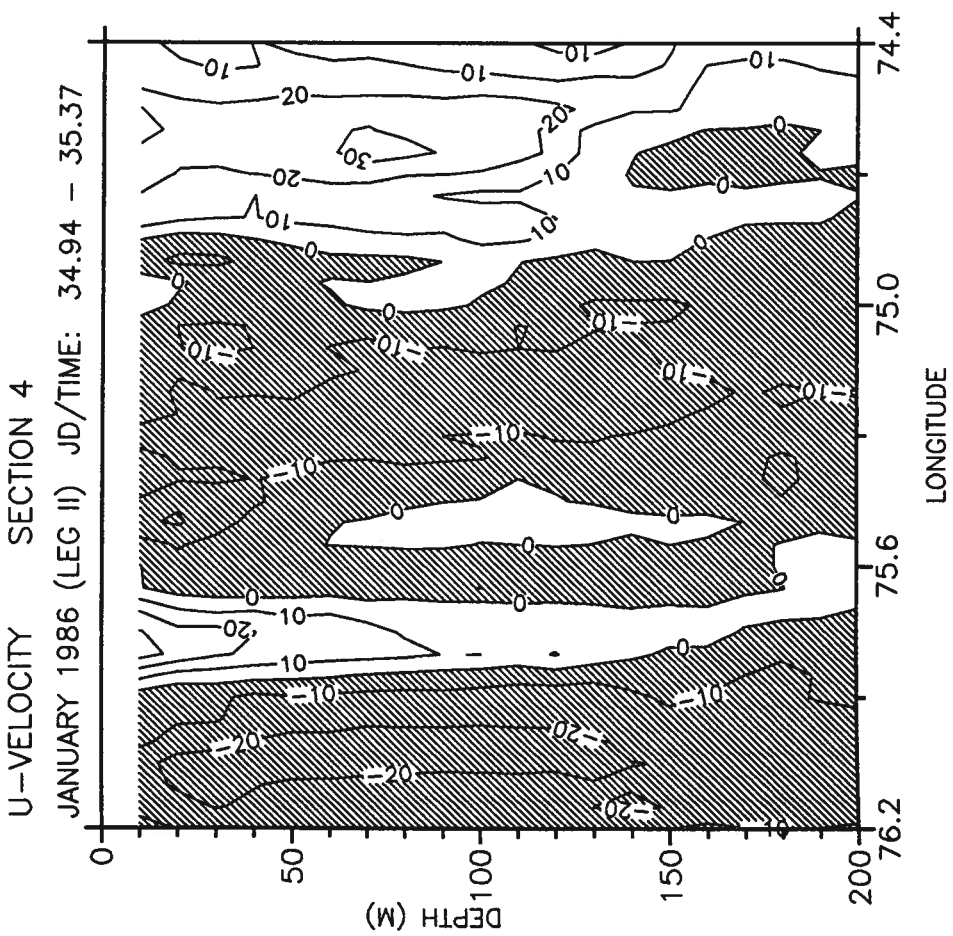
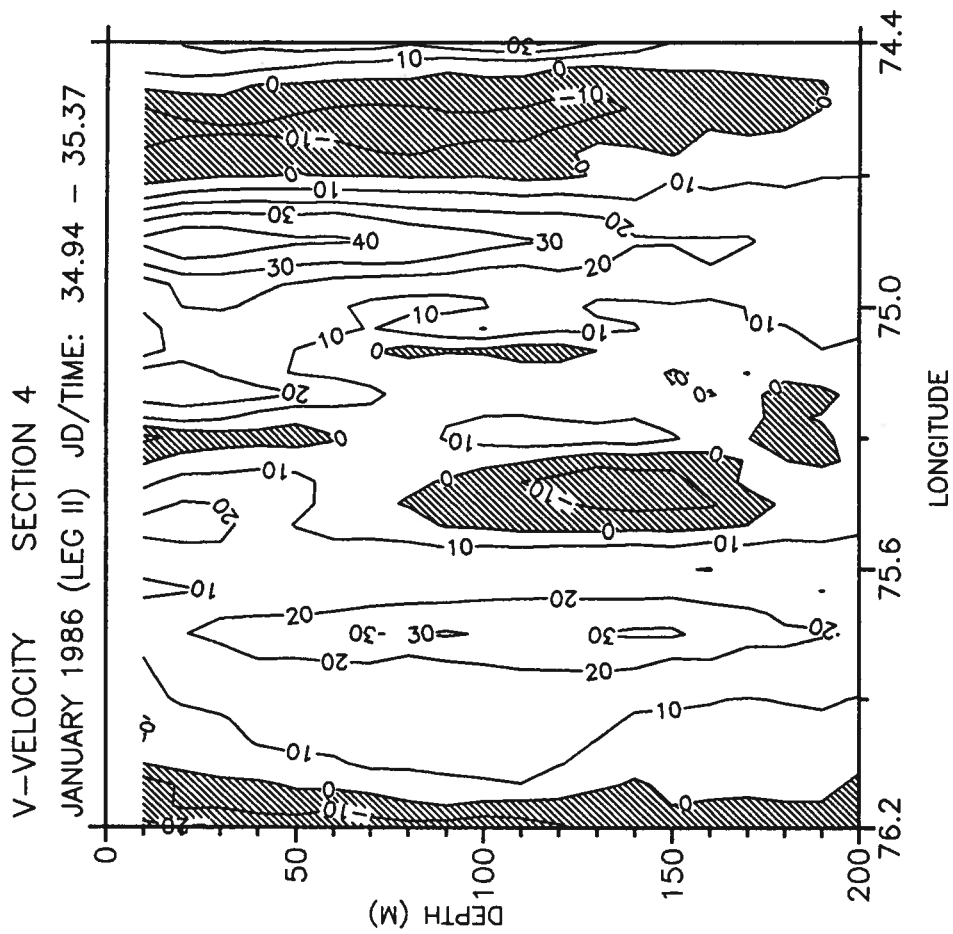

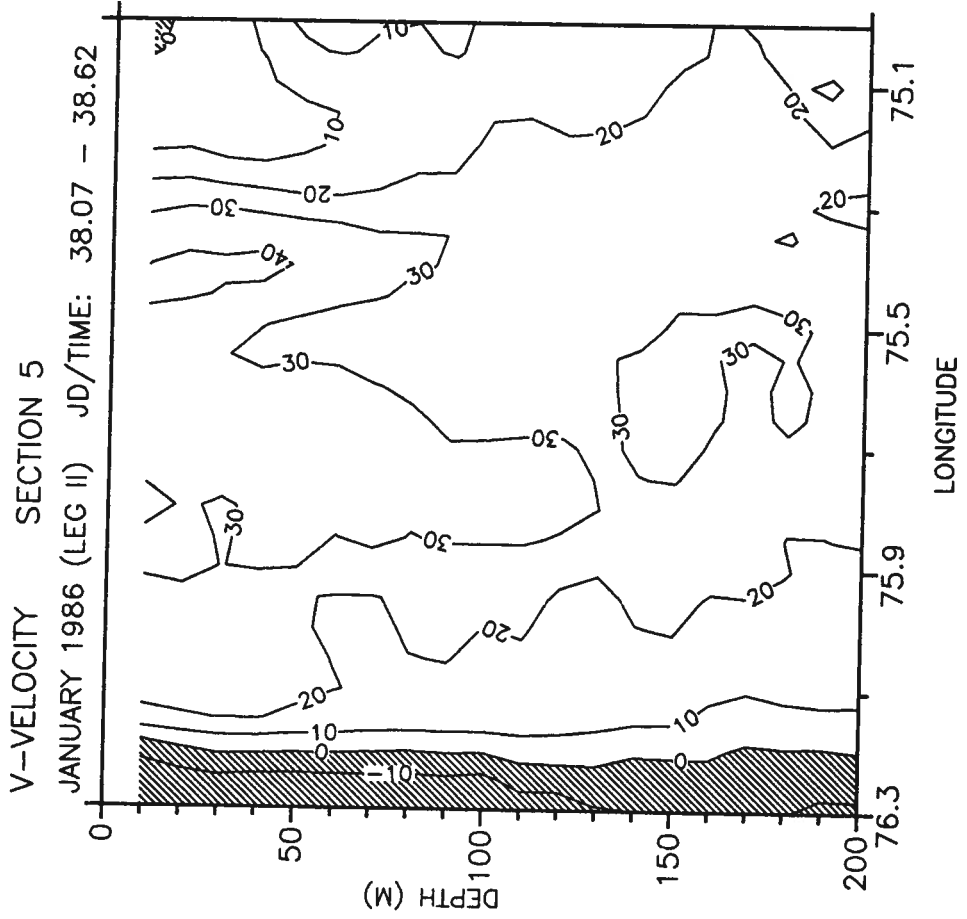
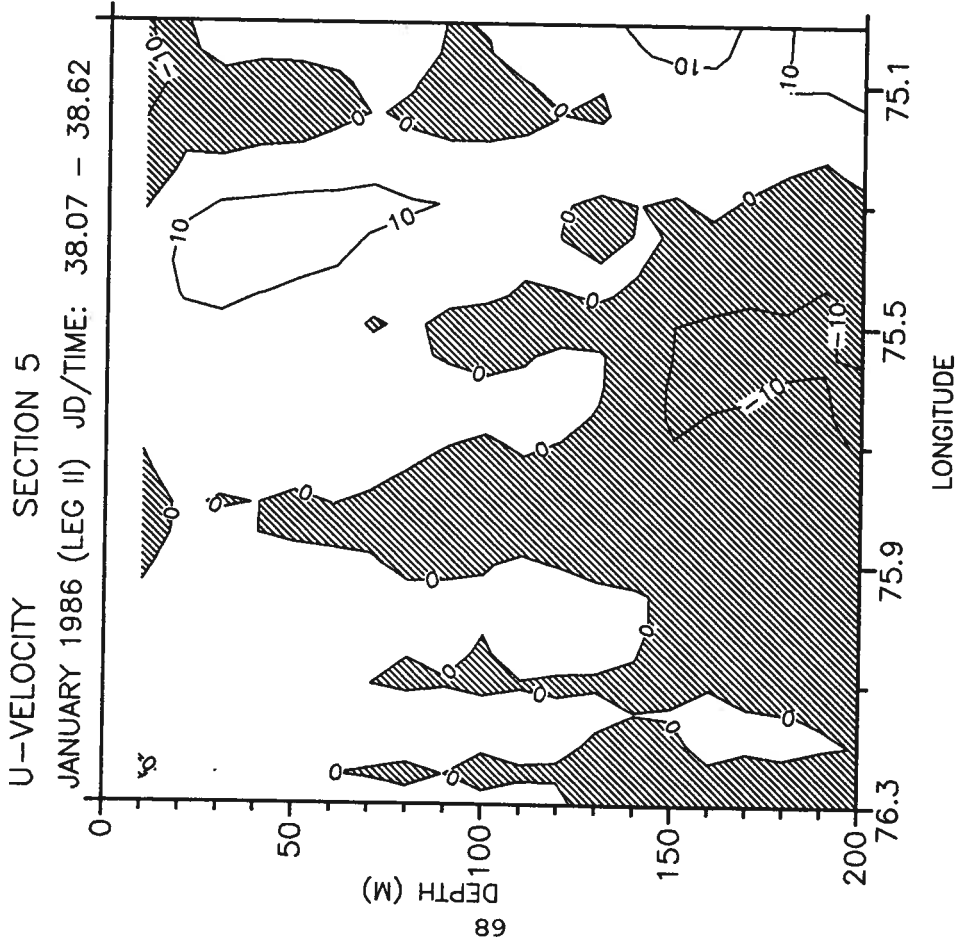

U-VELOCITY SECTION 6 (LORAN)

JANUARY 1986 (LEG II) JD/TIME: 40.35 - 40.45

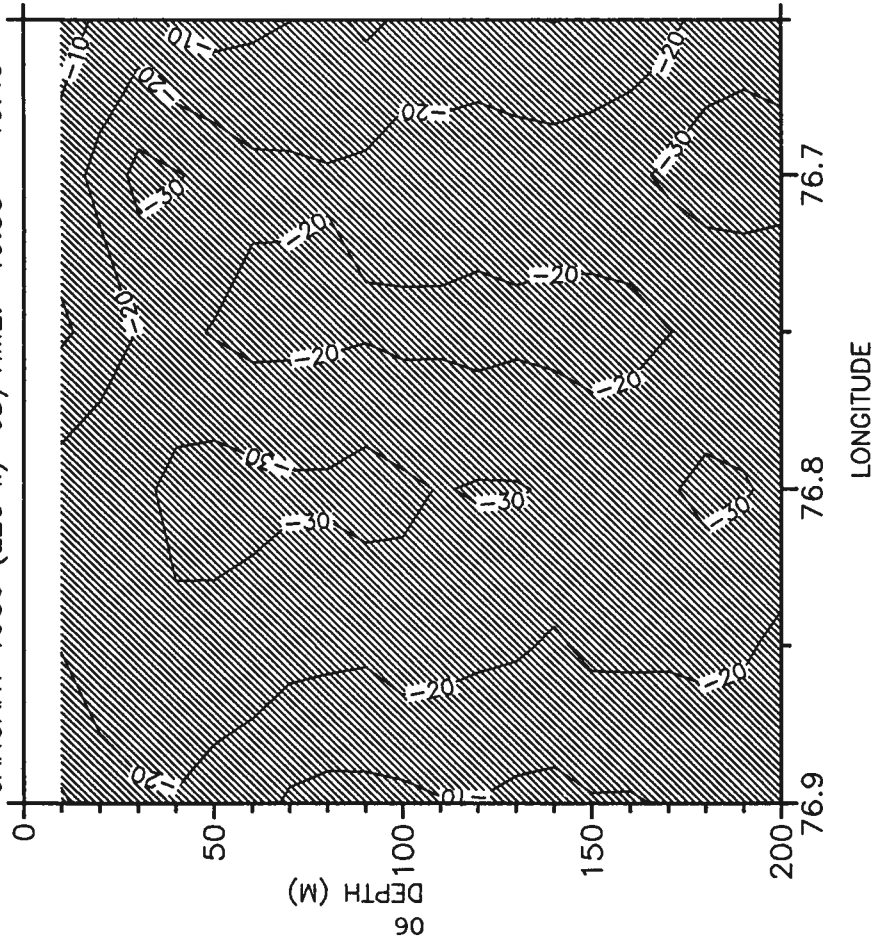

V-VELOCITY SECTION 6 (LORAN)

JANUARY 1986 (LEG II) JD/TIME: 40.35 - 40.45

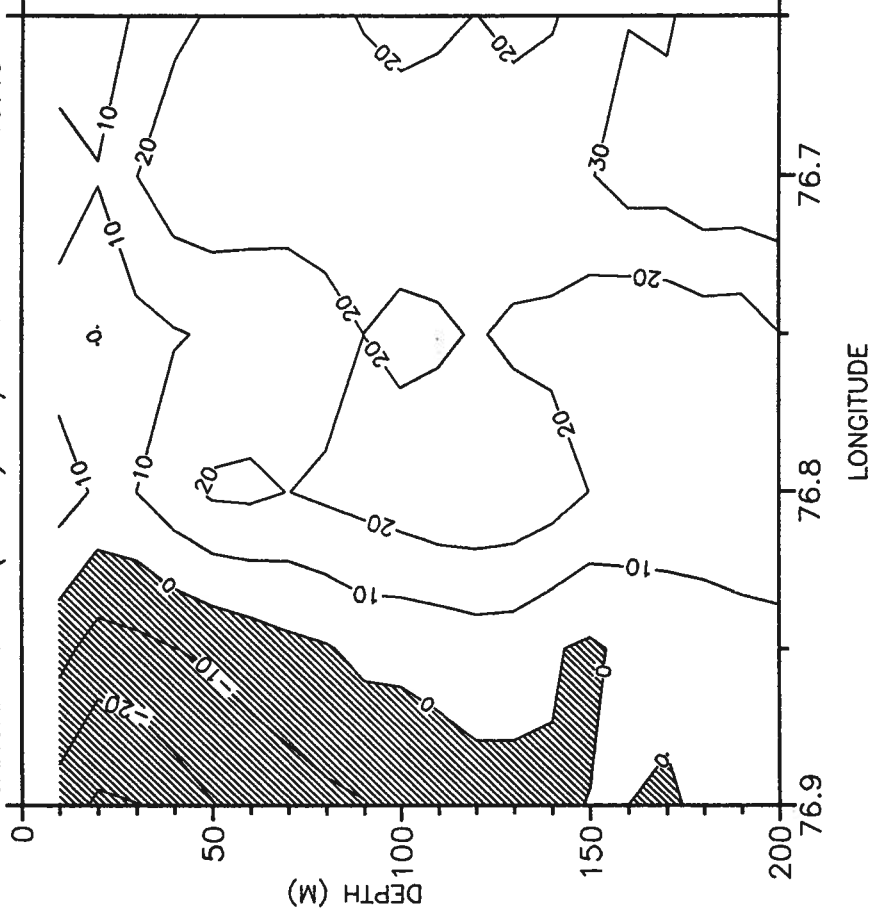

U-VELOCITY SECTION 7 (LORAN)

JANUARY 1986 (LEG II) JD/TIME: 40.48 - 40.96

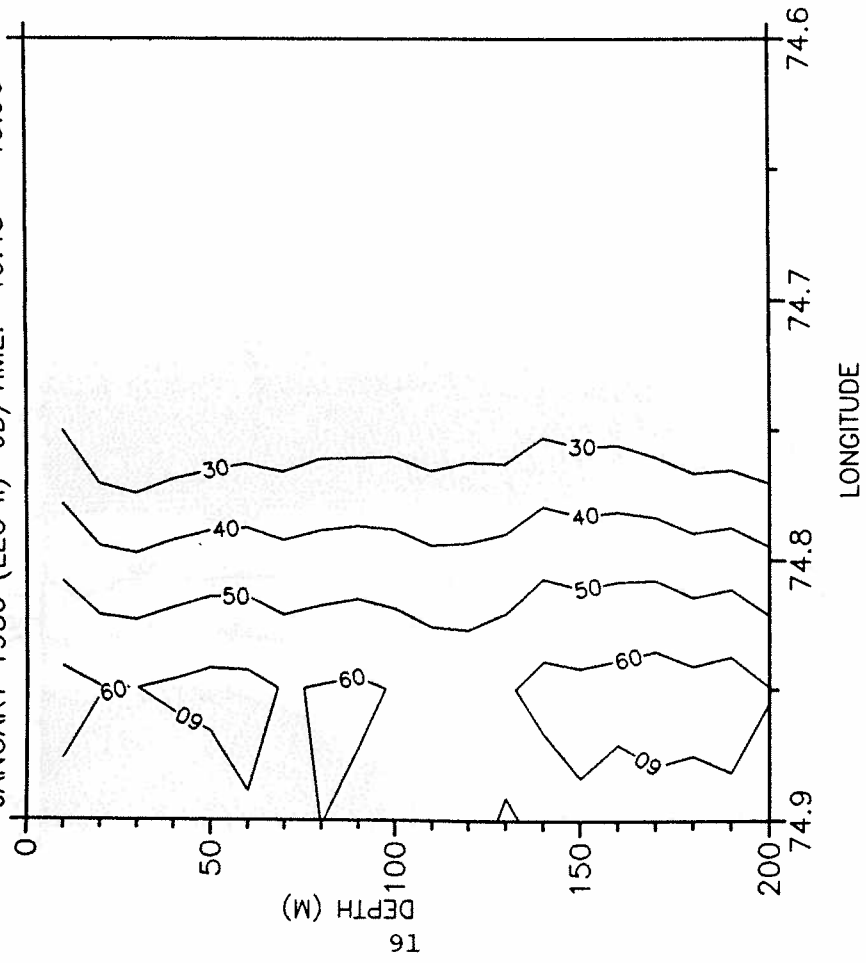

V-VELOCITY SECTION 7 (LORAN)

JANUARY 1986 (LEG II) JD/TIME: 40.48 - 40.96

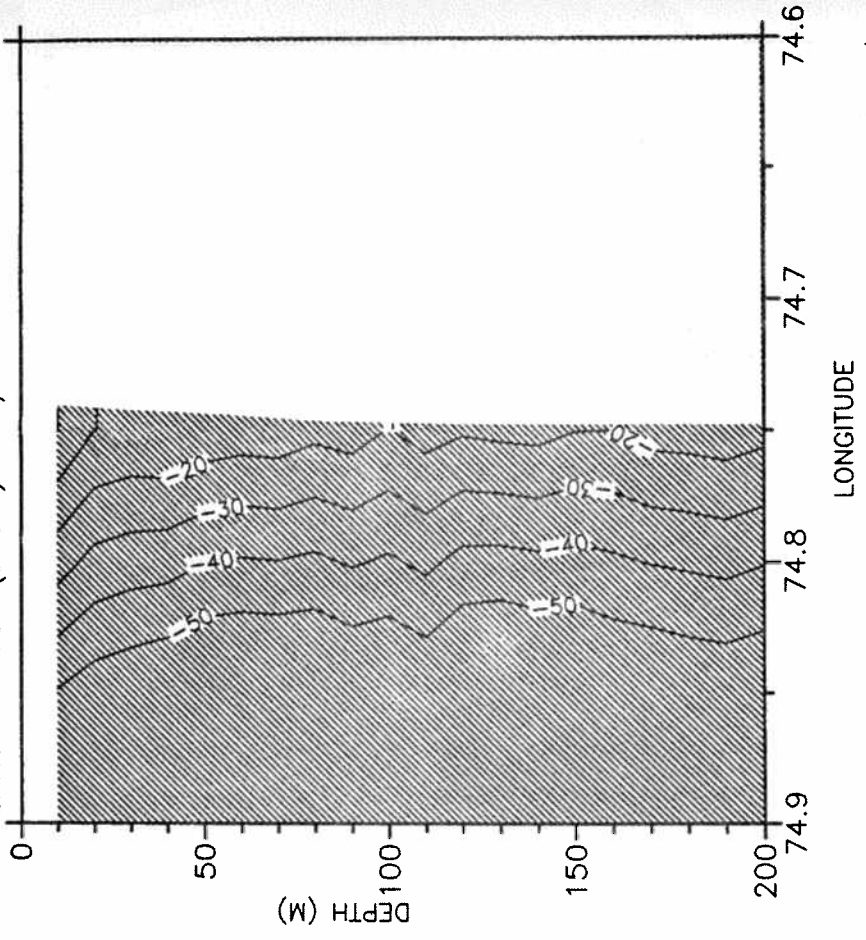

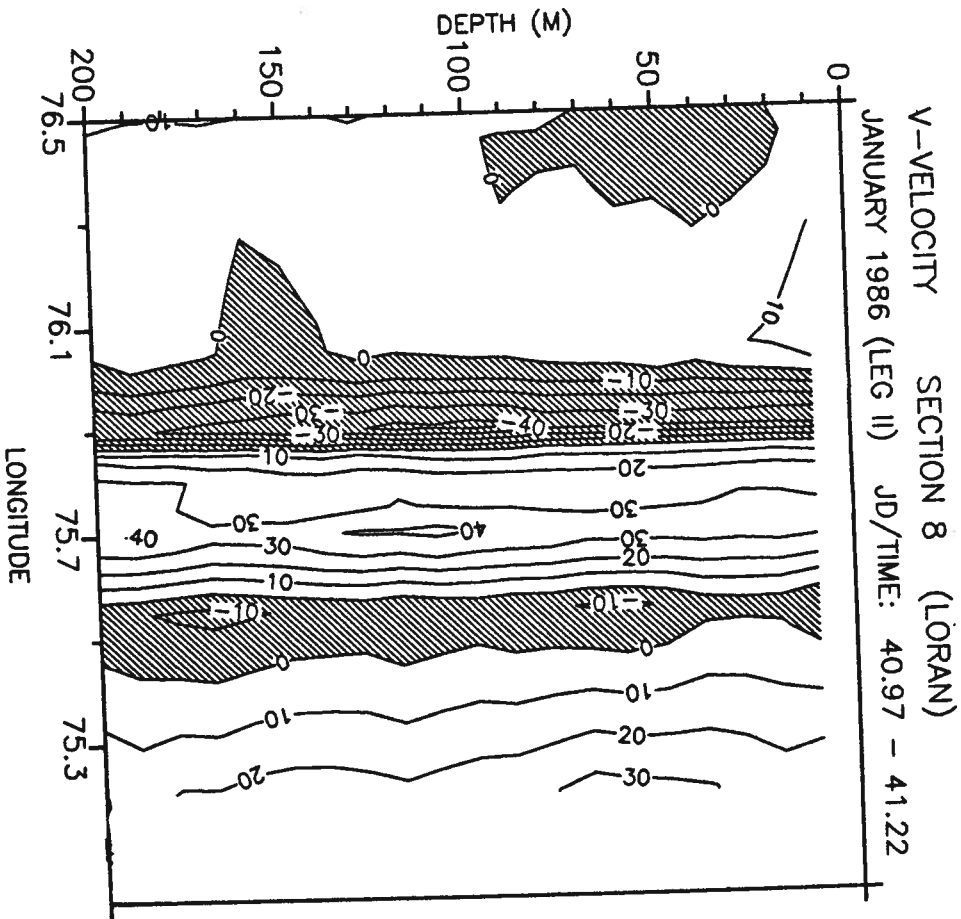
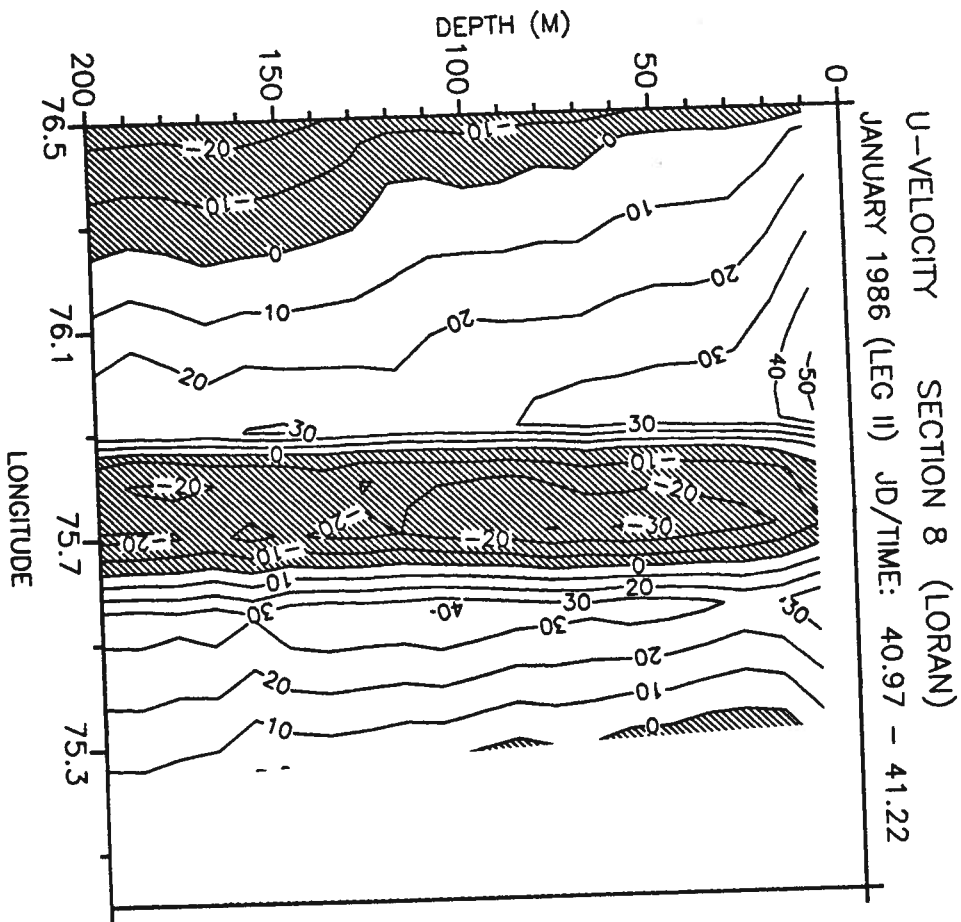

U-VELOCITY SECTION 9 (LORAN C)

JANUARY 1986 (LEG II) JD/TIME: 41.23 - 41.40

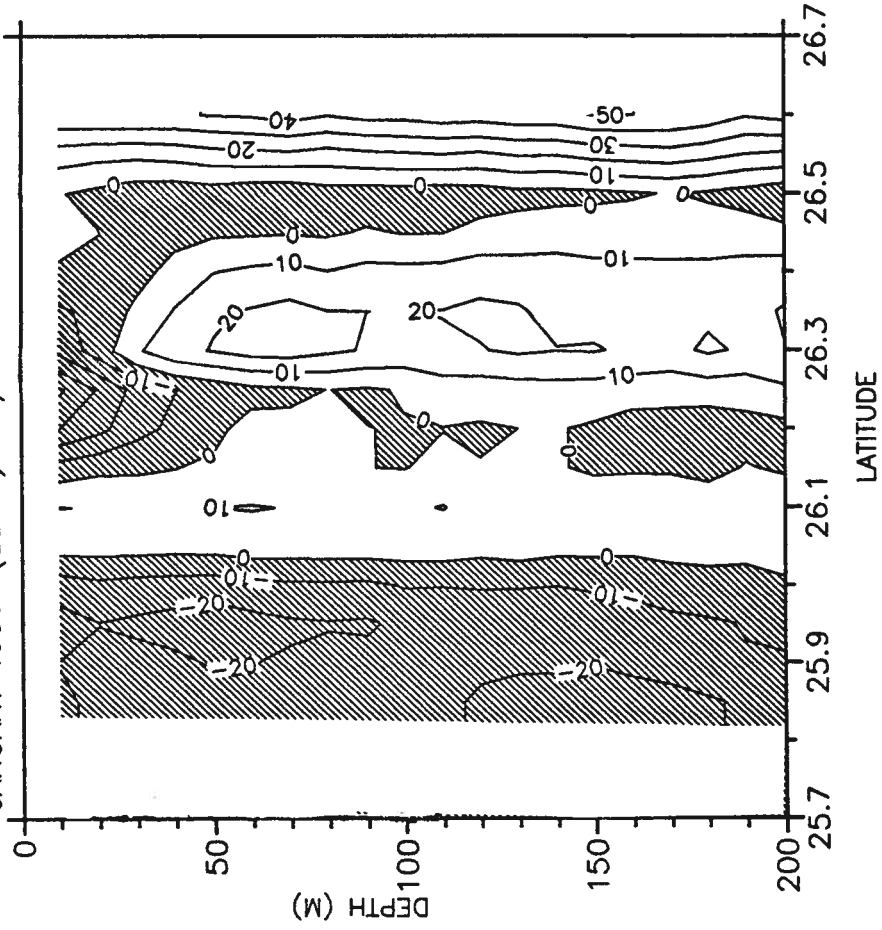

V-VELOCITY SECTION 9 (LORAN C)

JANUARY 1986 (LEG II) JD/TIME: 41.23 - 41.40

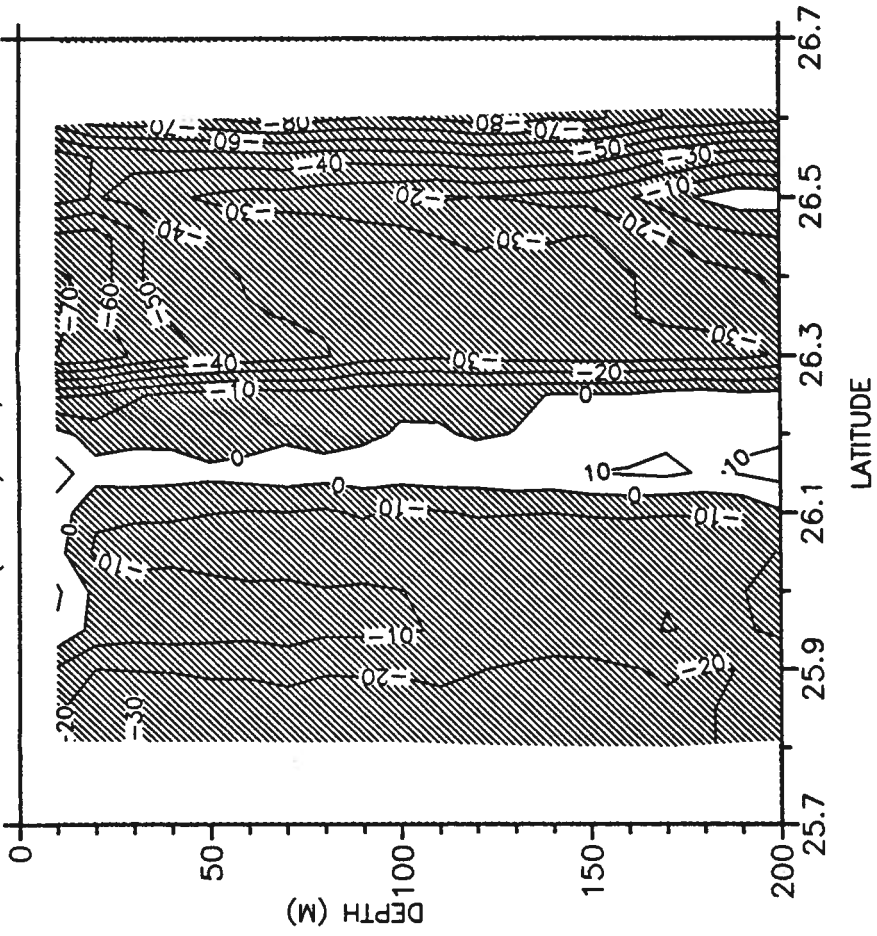



U-VELOCITY SECTION 9 (LORAN C)

JANUARY 1986 (LEG II) JD/TIME: 41.23 - 41.40

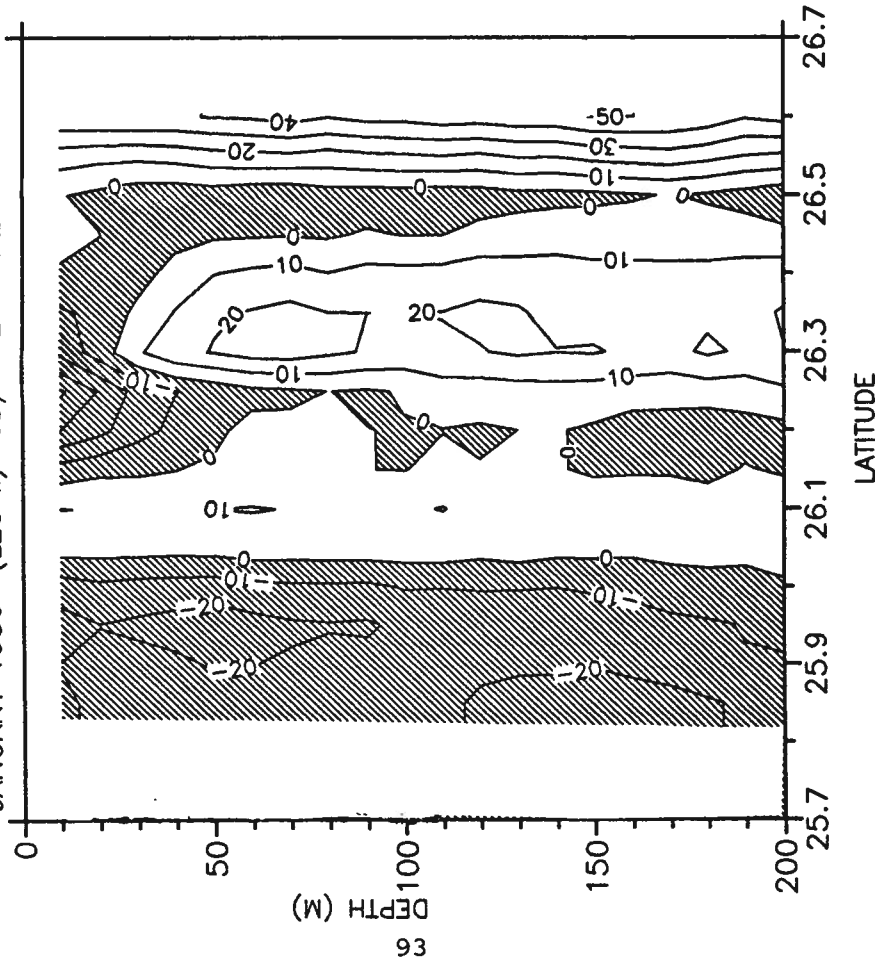

V-VELOCITY SECTION 9 (LORAN C)

JANUARY 1986 (LEG II) JD/TIME: 41.23 - 41.40

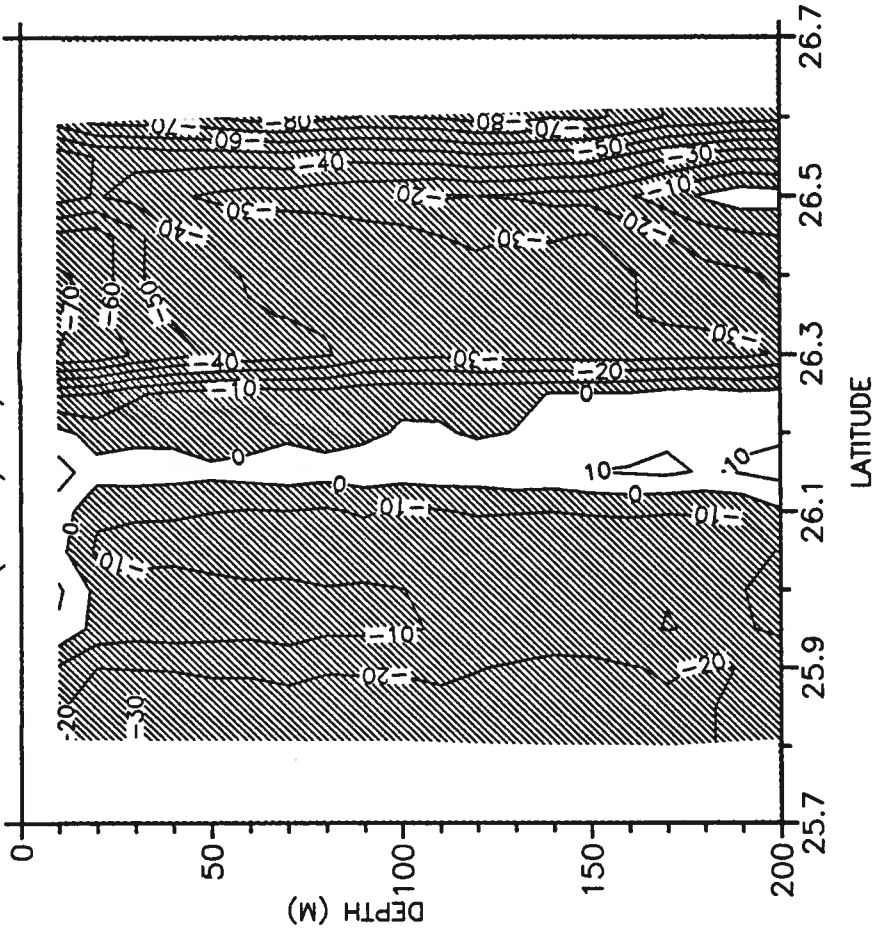

U-VELOCITY SECTION 10 (LORAN)

JANUARY 1986 (LEG II) JD/TIME: 41.41 - 42.49

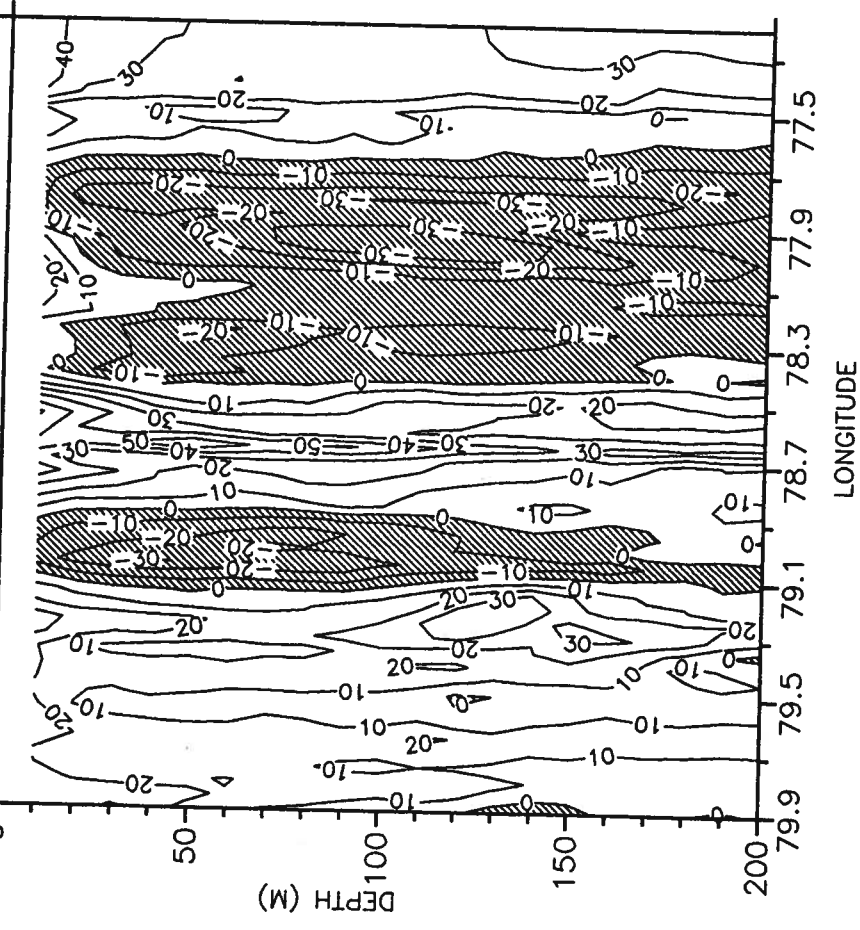

V-VELOCITY SECTION 10 (LORAN)

JANUARY 1986 (LEG II) JD/TIME: 41.41 - 42.49

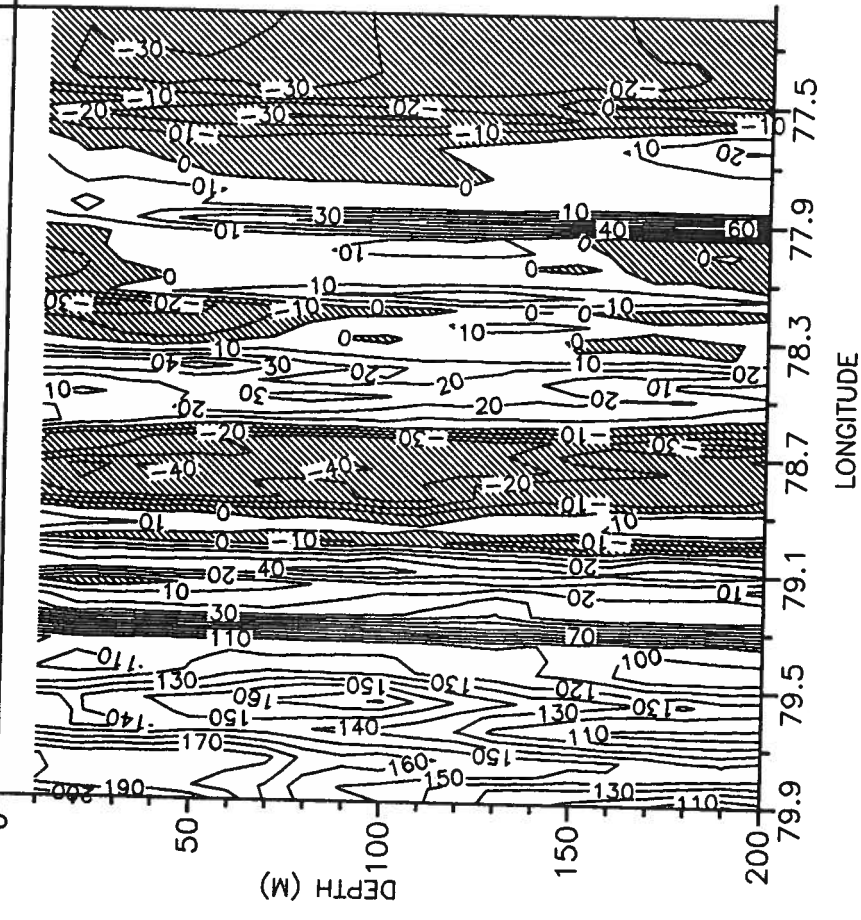

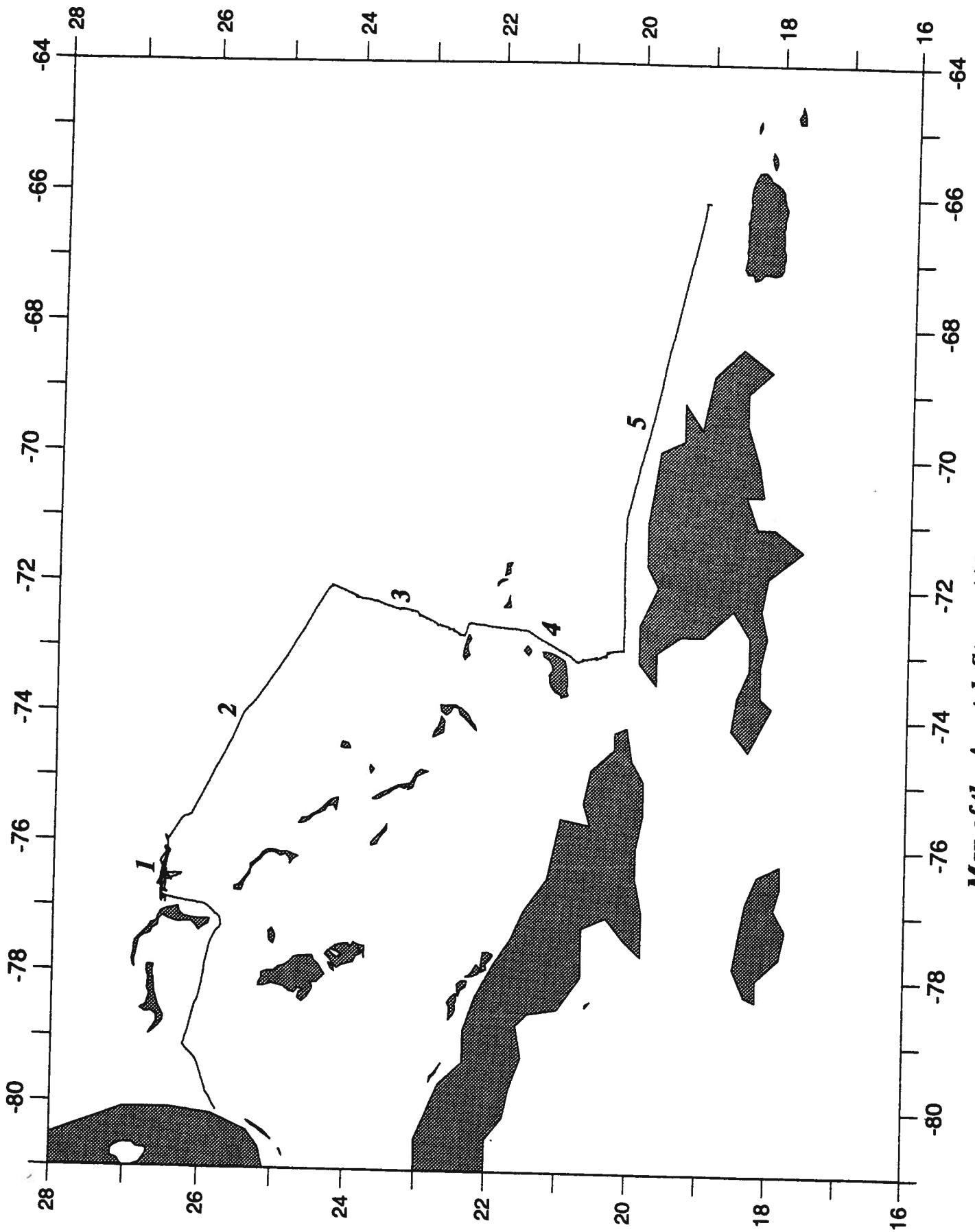

*Map of the Ametek-Straza (ADCP) trackline - March 1986*

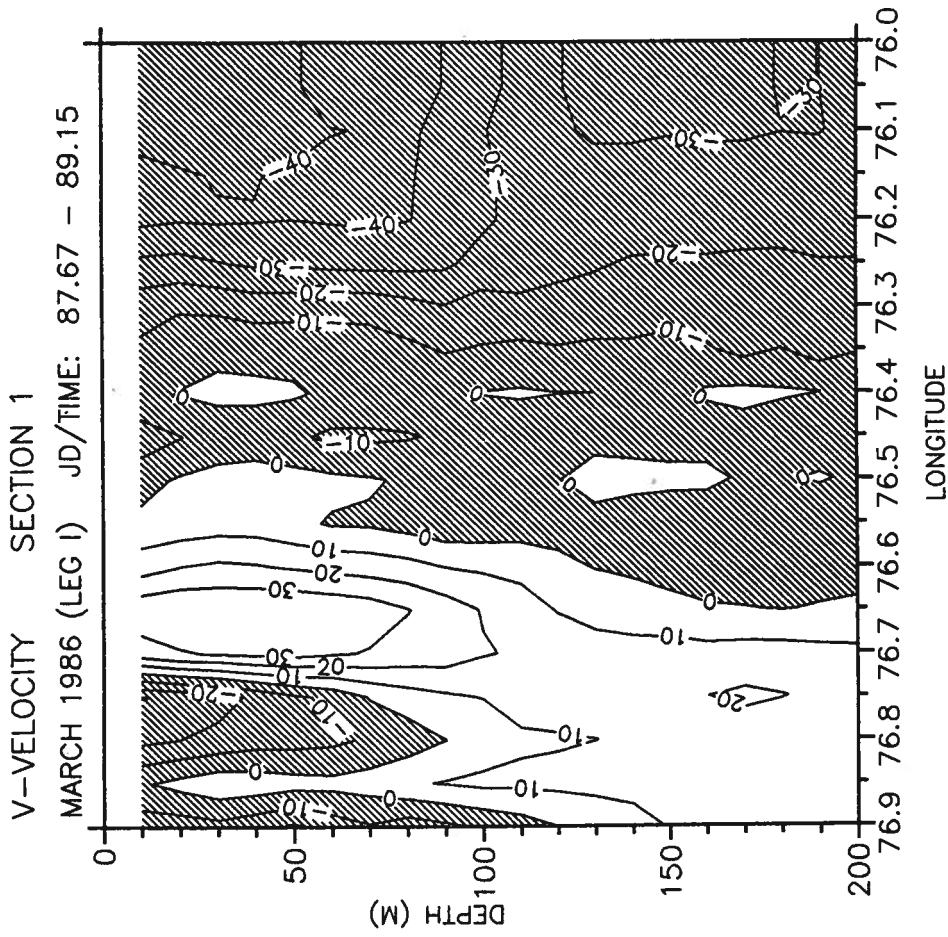
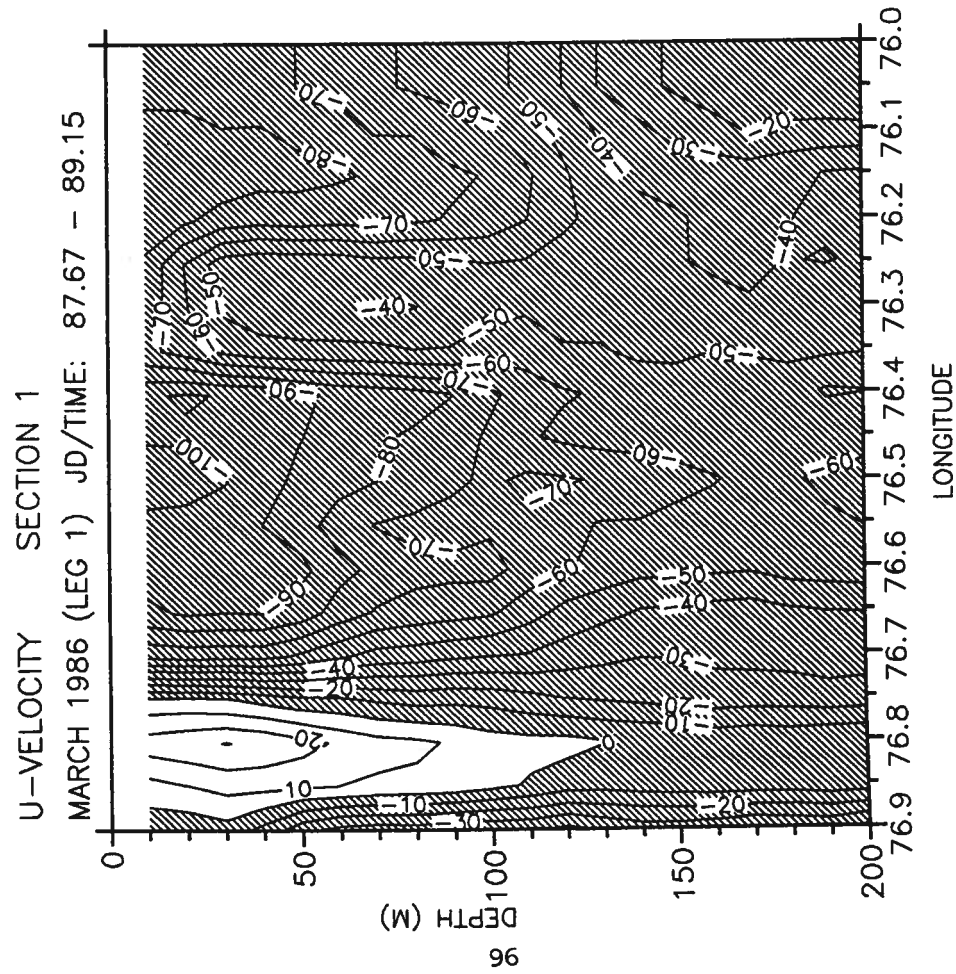

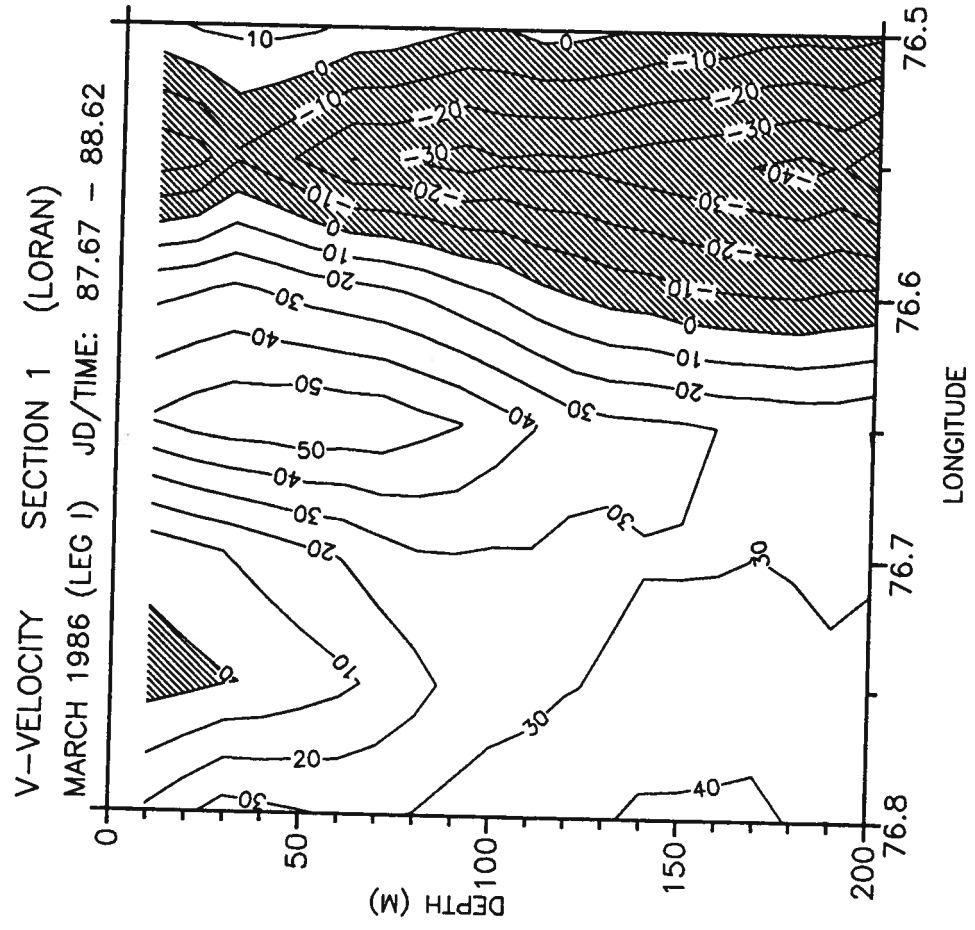
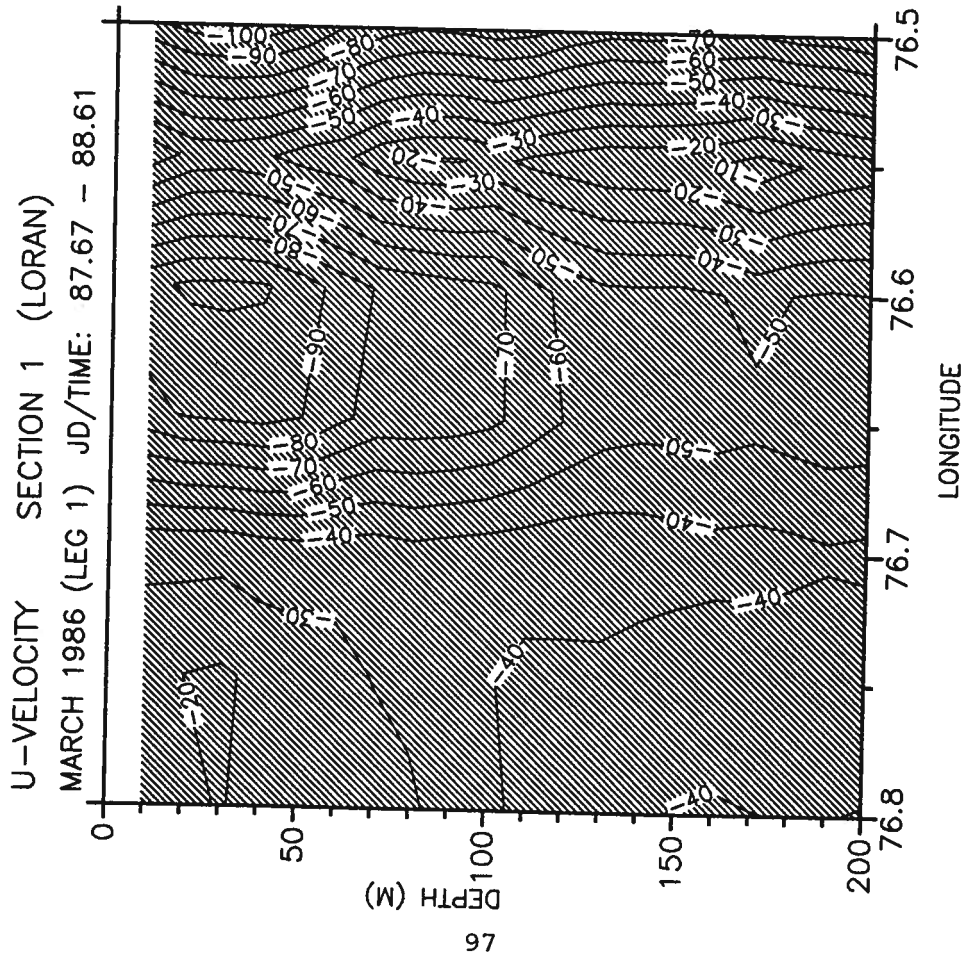

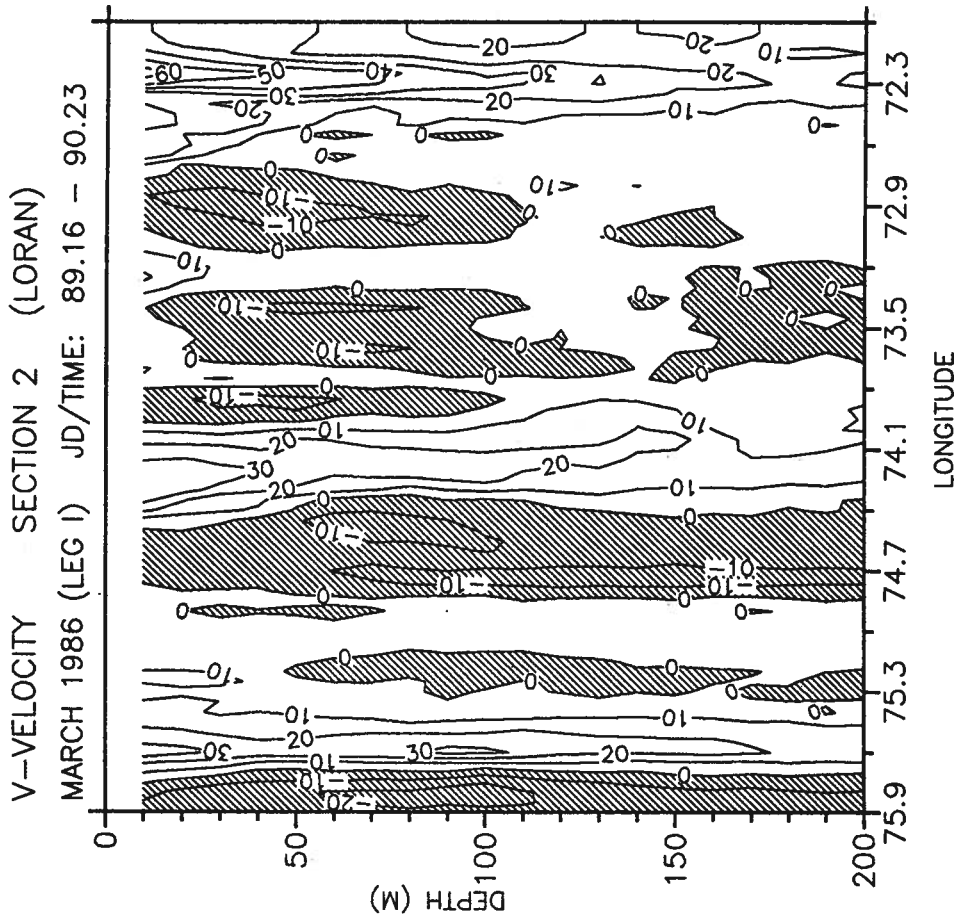
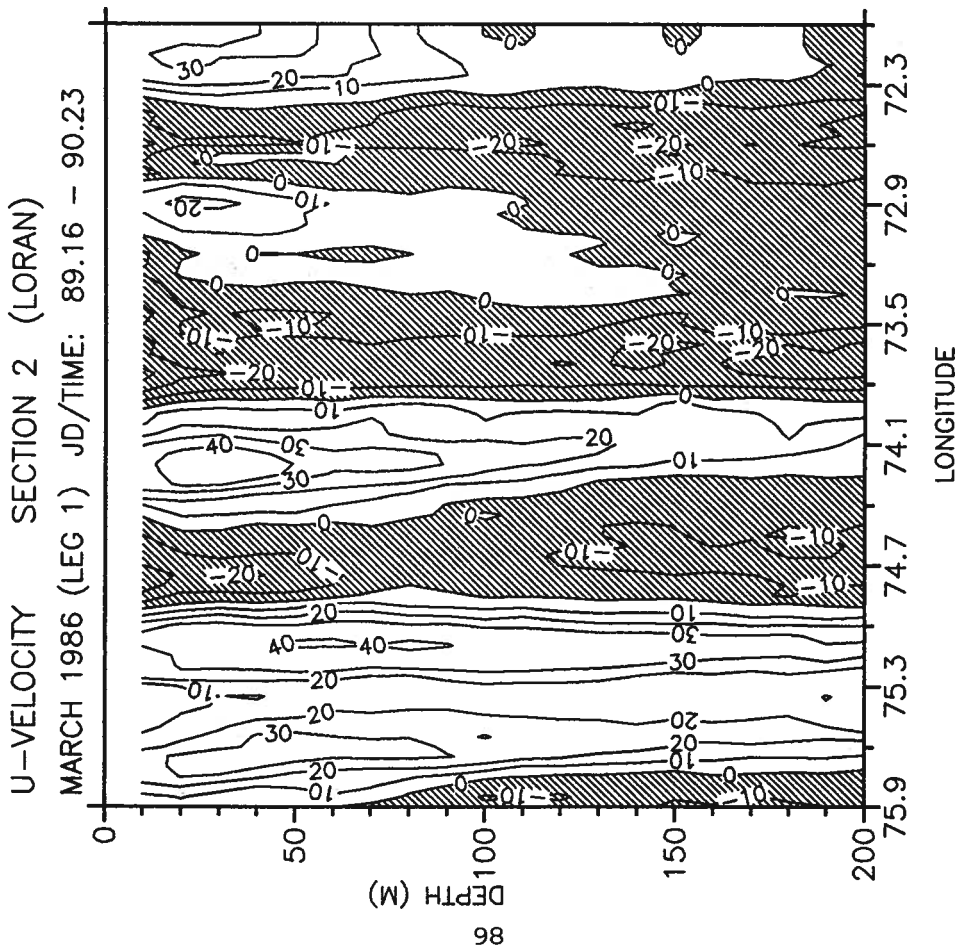

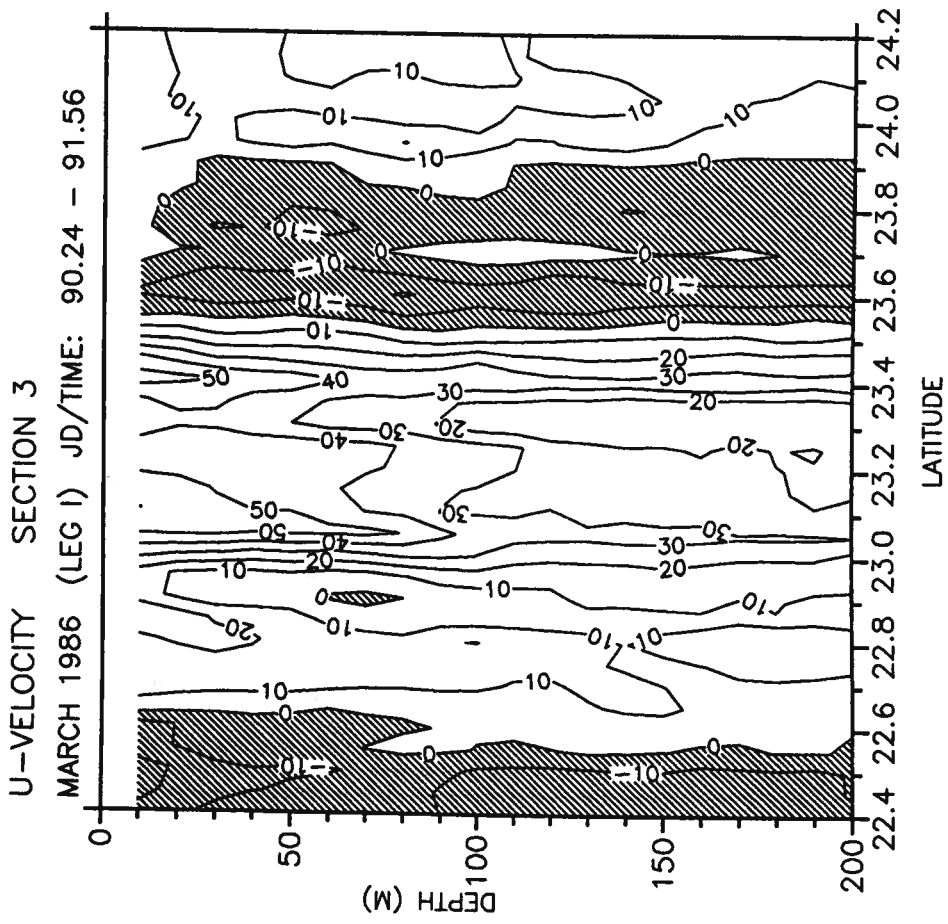
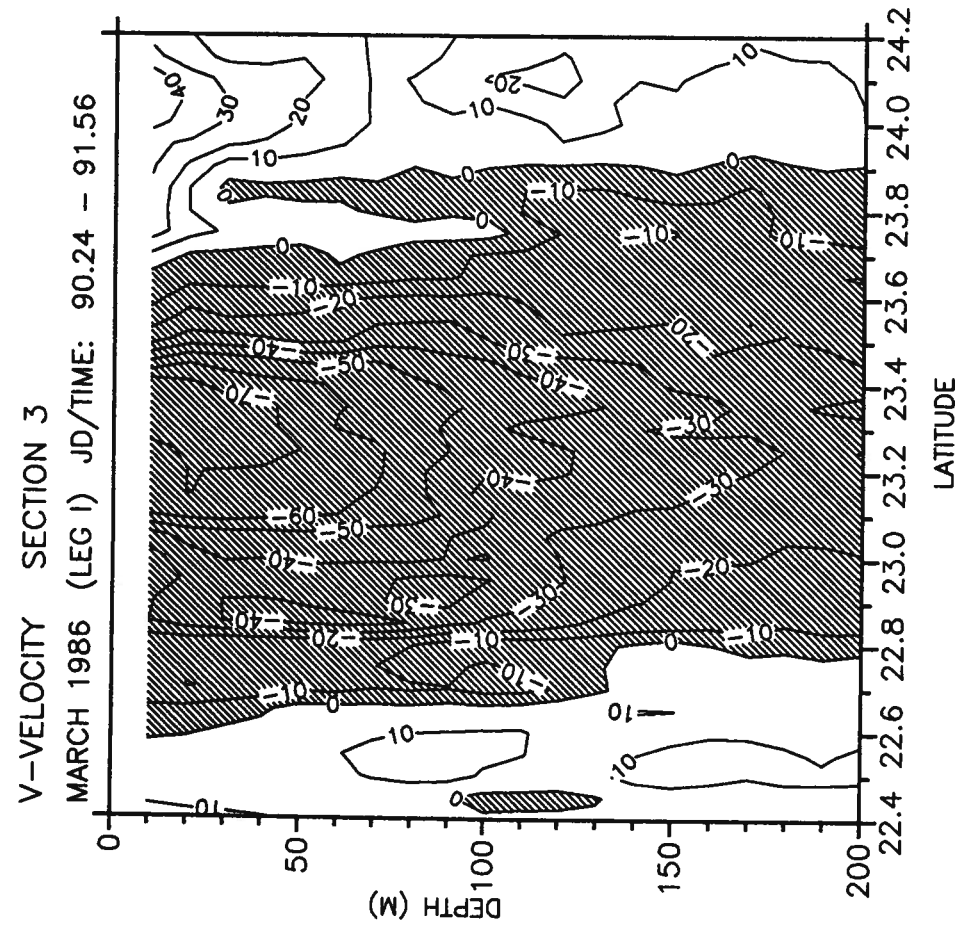

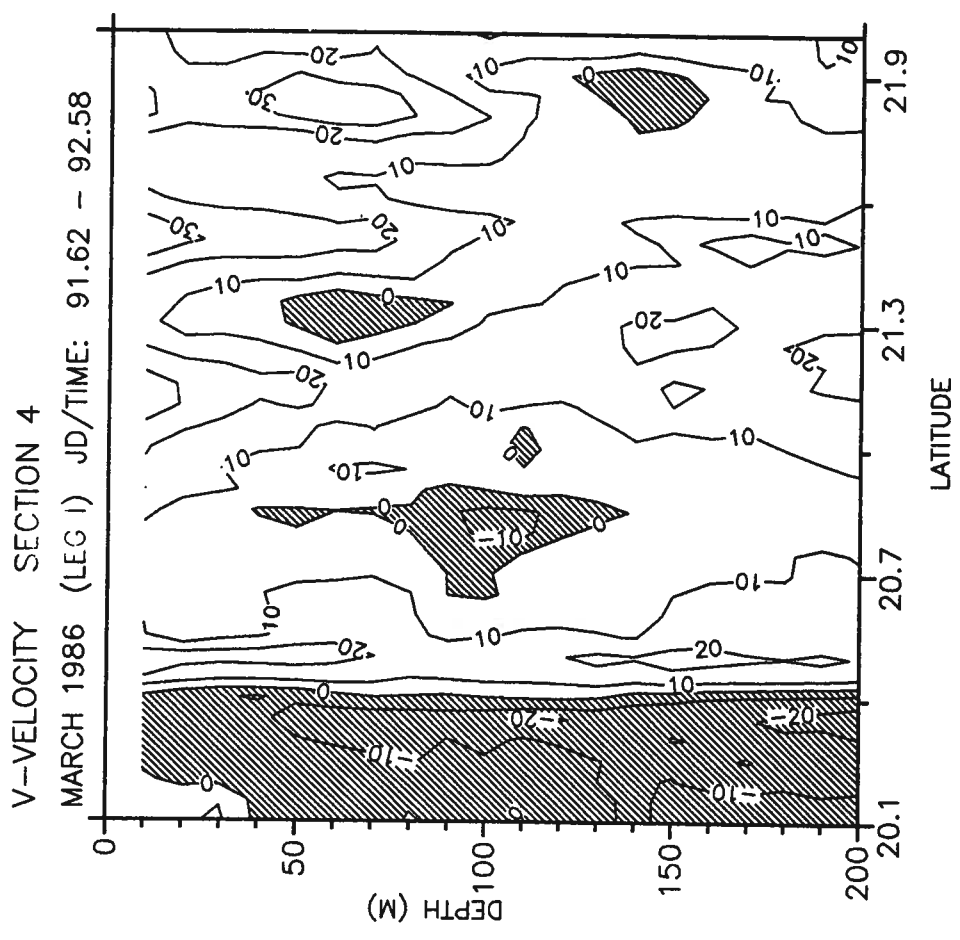
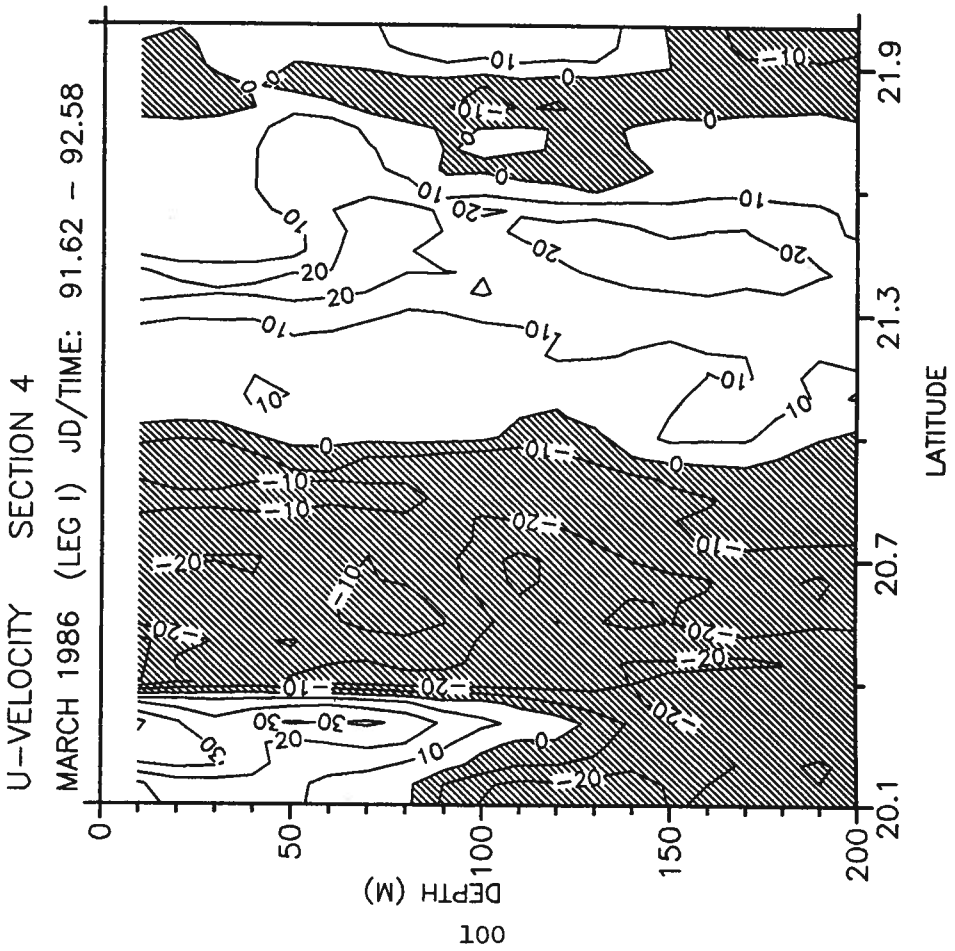



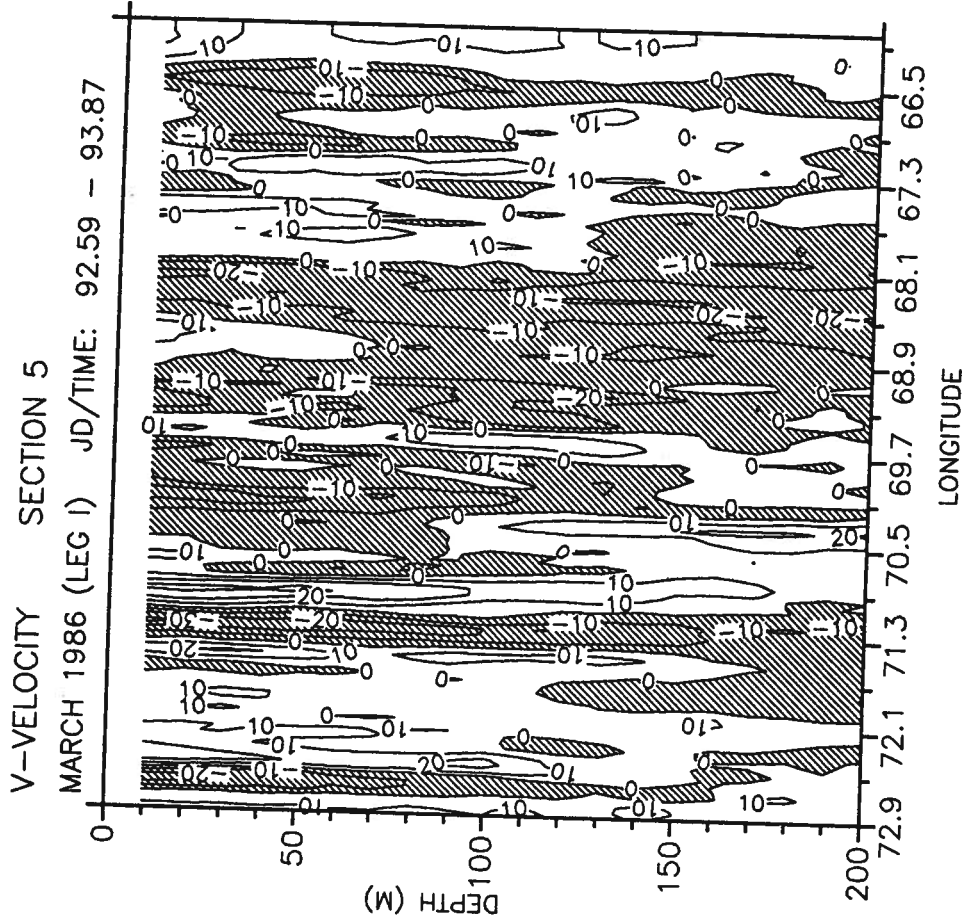
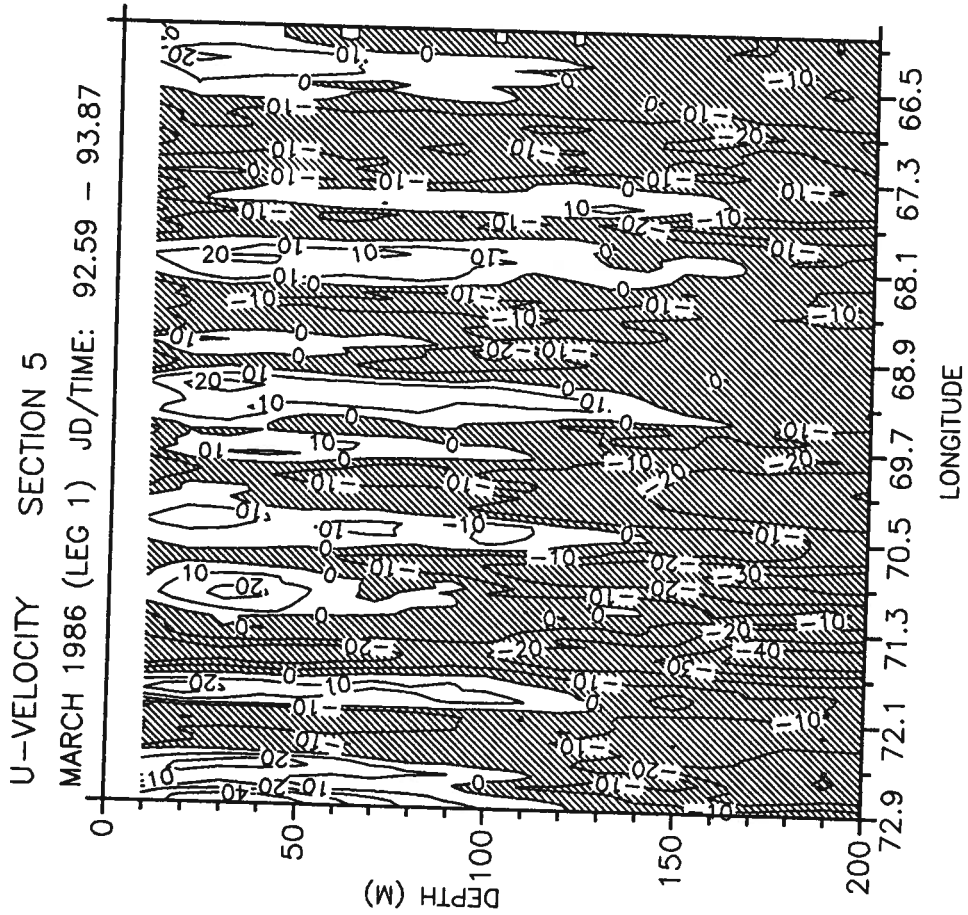

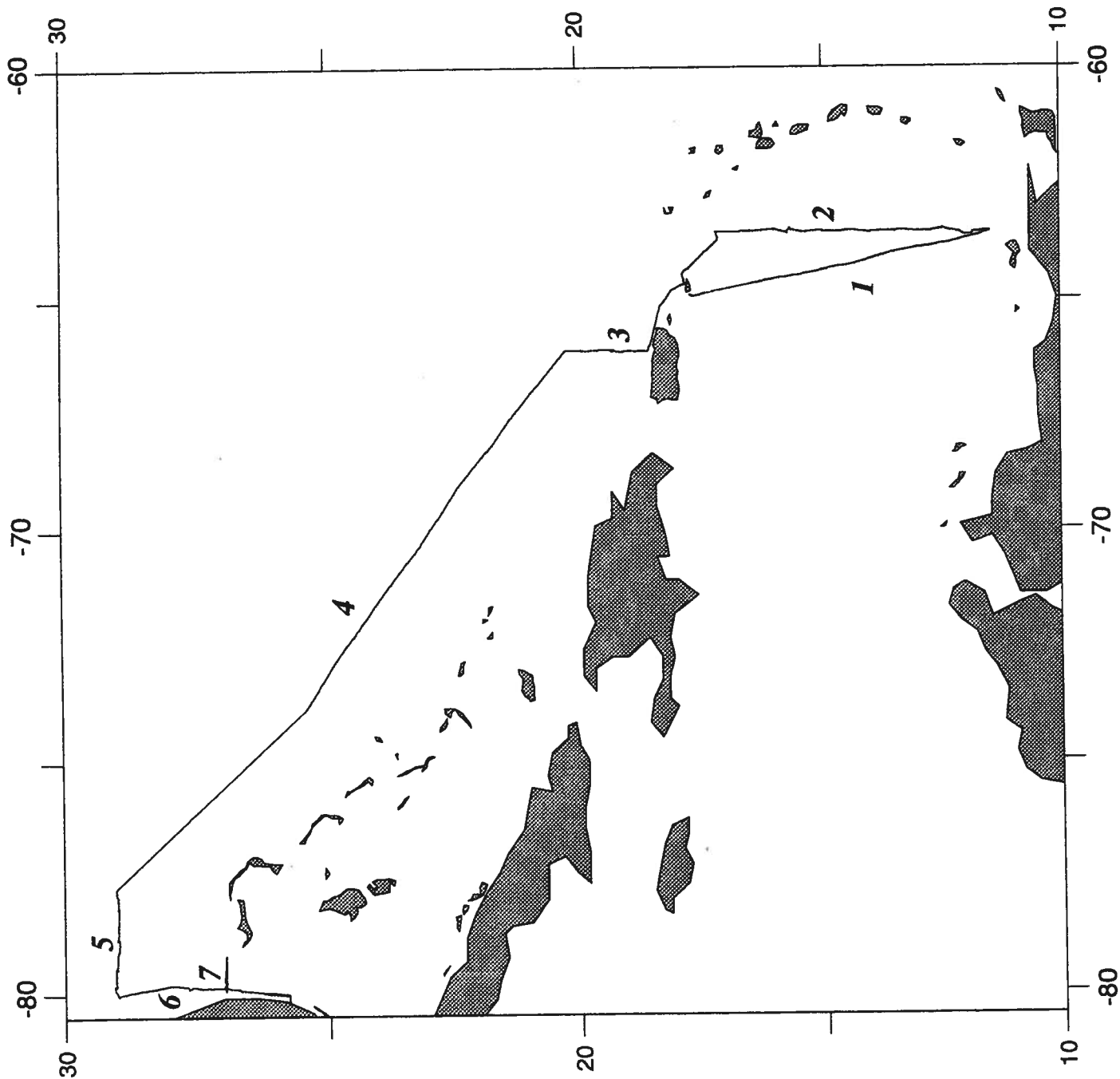

*Map of the Ametek-Straza (ADCP) trackline - March 1986 (Leg II)*

U-VELOCITY SECTION 1

MARCH 1986 (LEG II) JD/TIME: 99.87 - 99.76

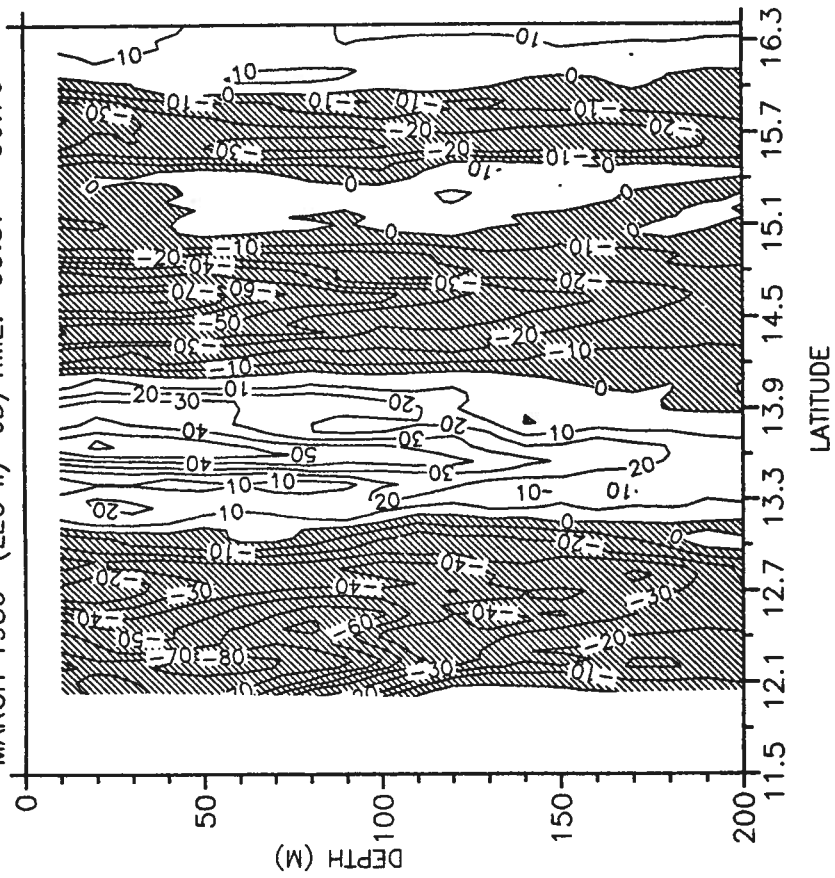

V-VELOCITY SECTION 1

MARCH 1986 (LEG II) JD/TIME: 98.87 - 99.76

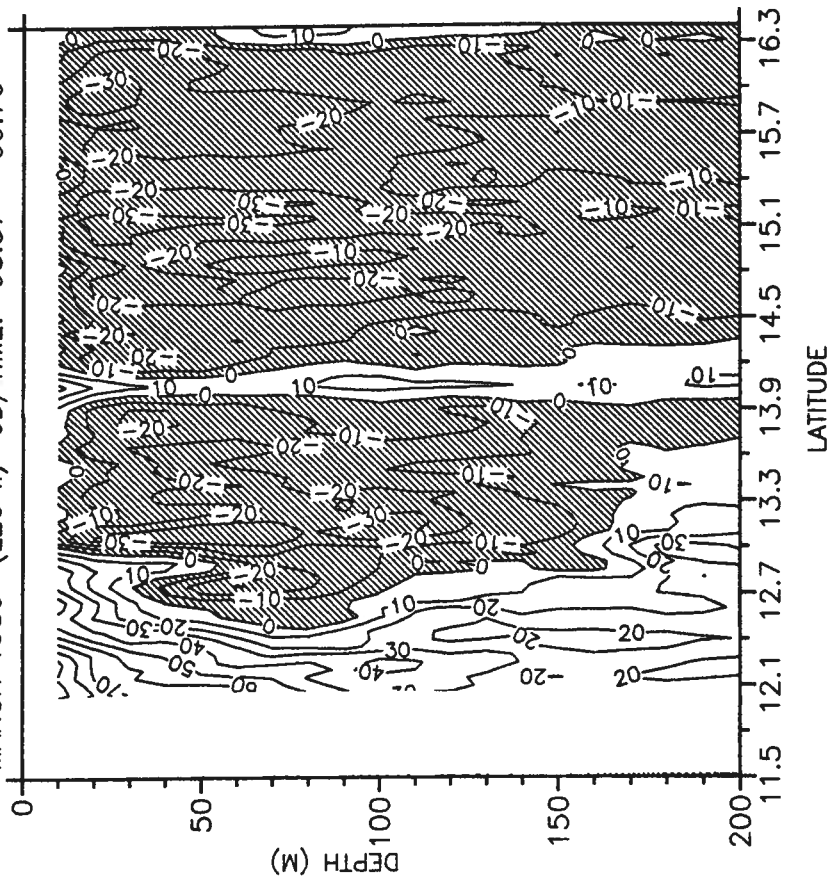

V-VELOCITY SECTION 2

MARCH 1986 (LEG II) JD/TIME: 99.82 - 102.20

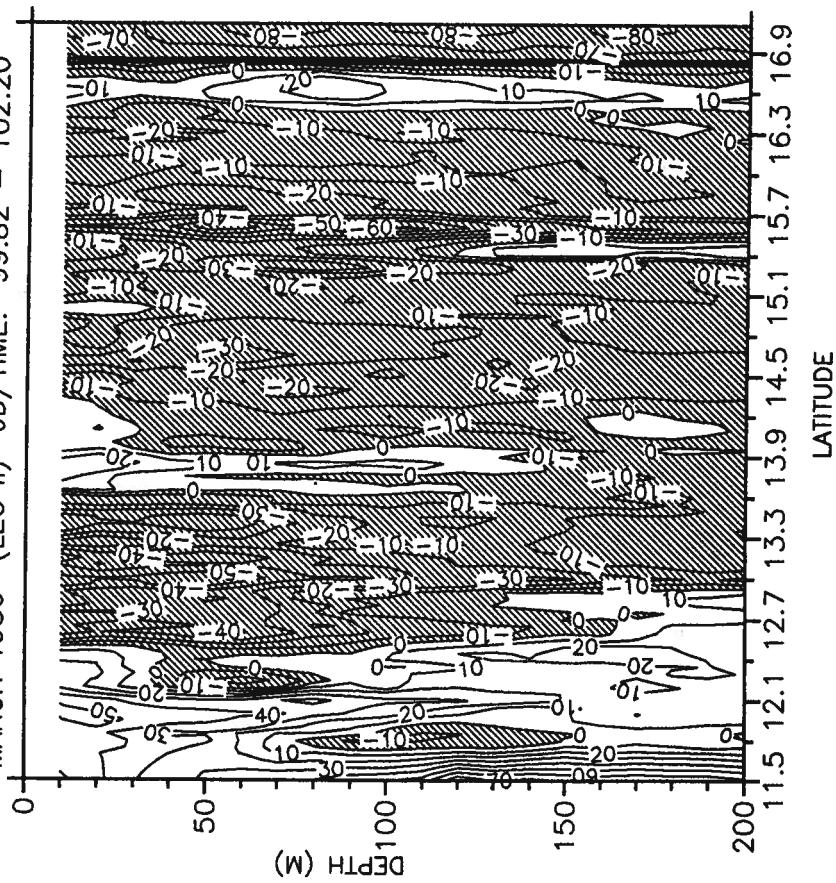

U-VELOCITY SECTION 2

MARCH 1986 (LEG II) JD/TIME: 99.82 - 102.20

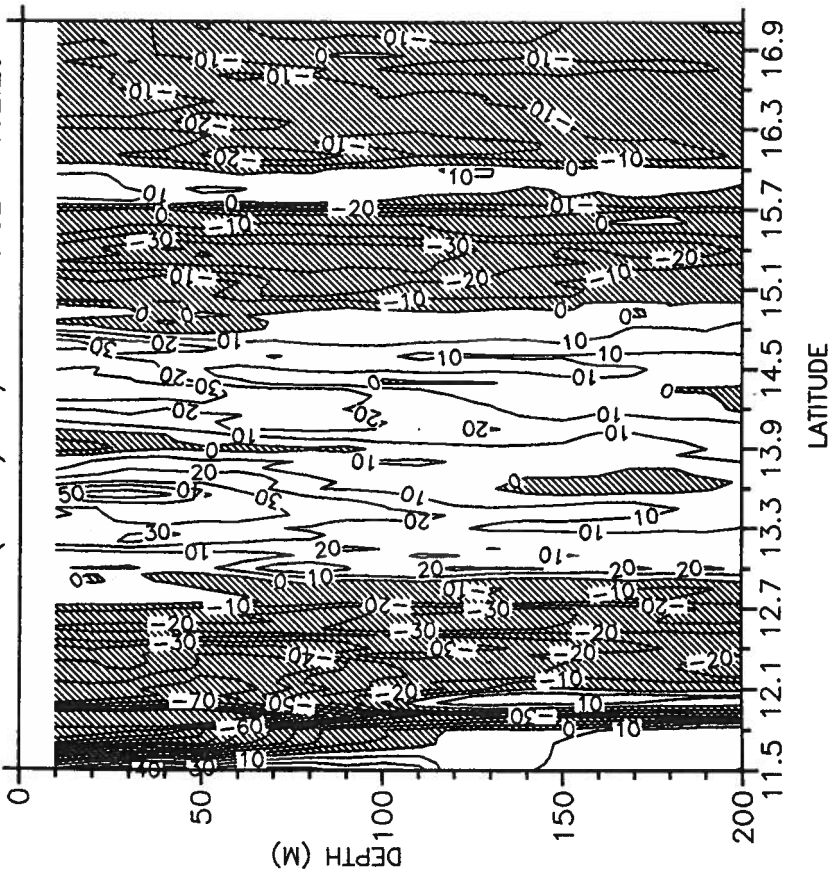

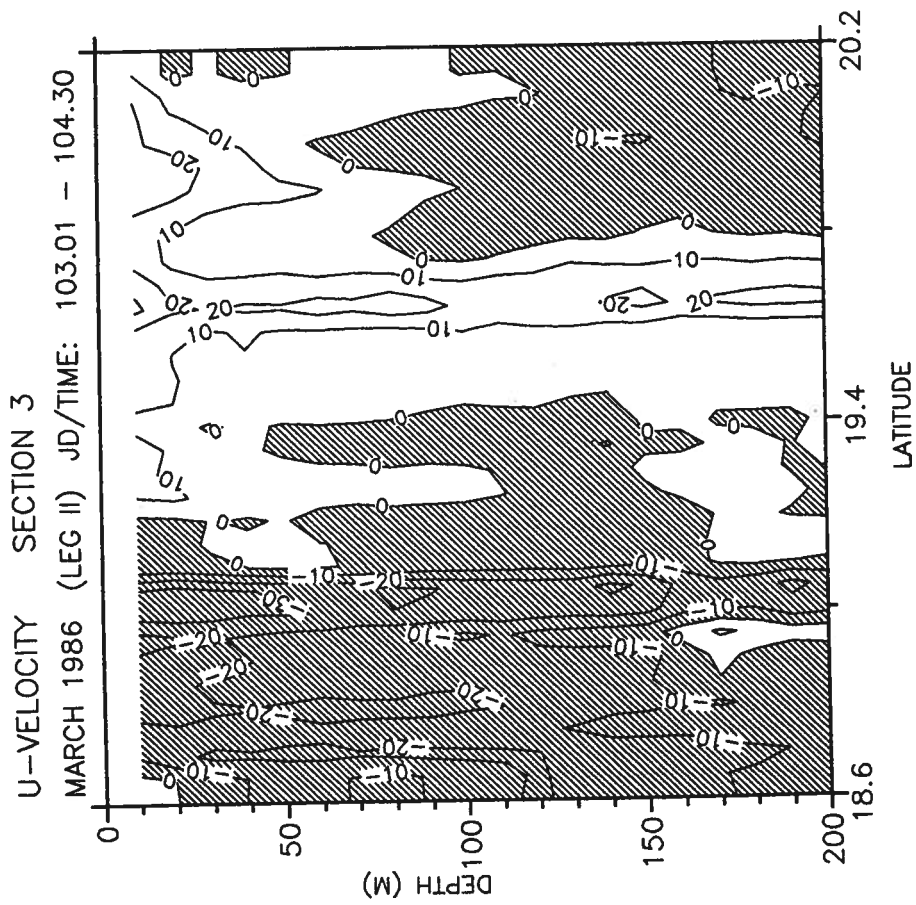
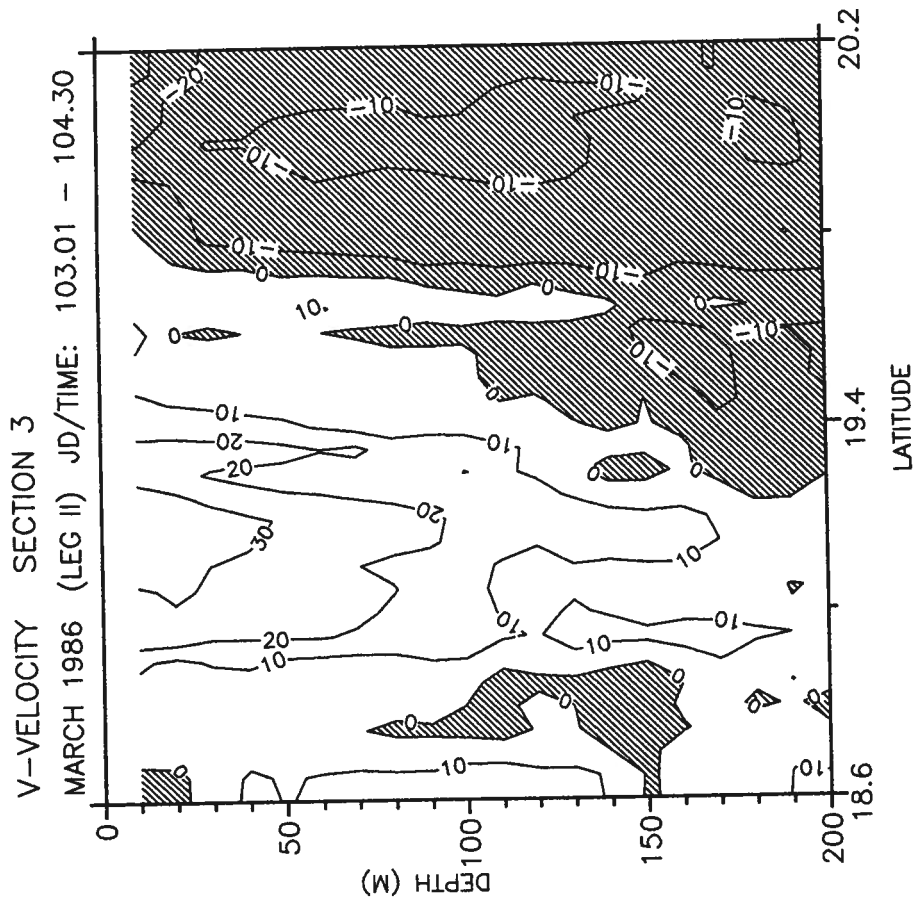

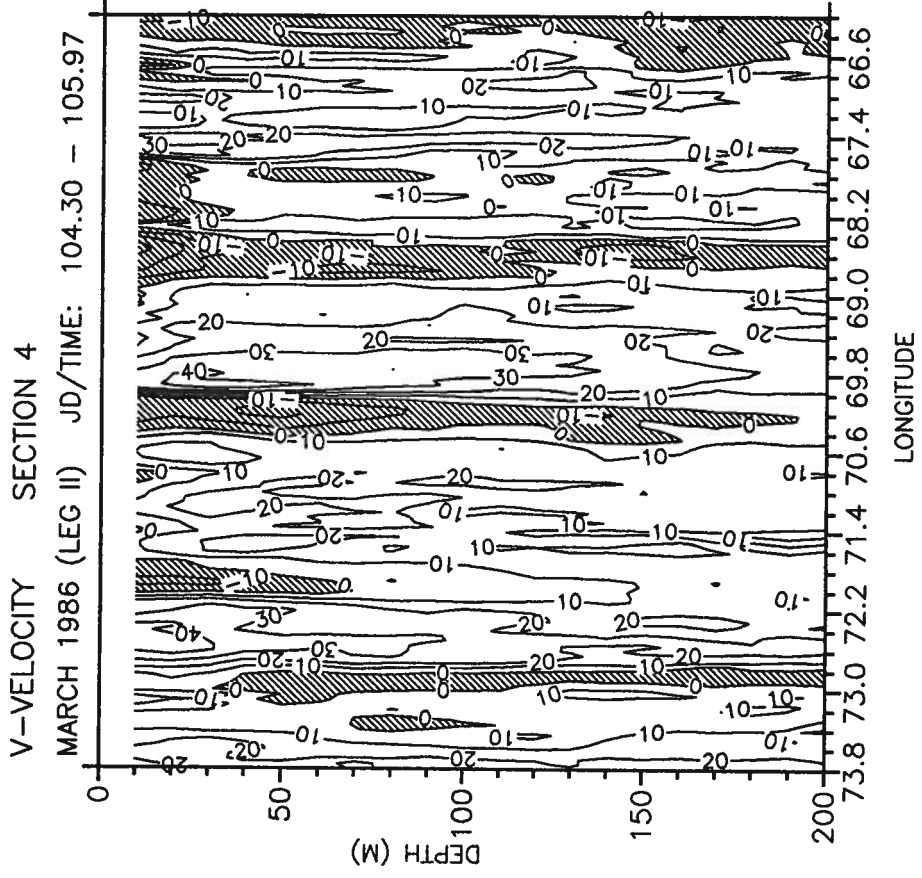
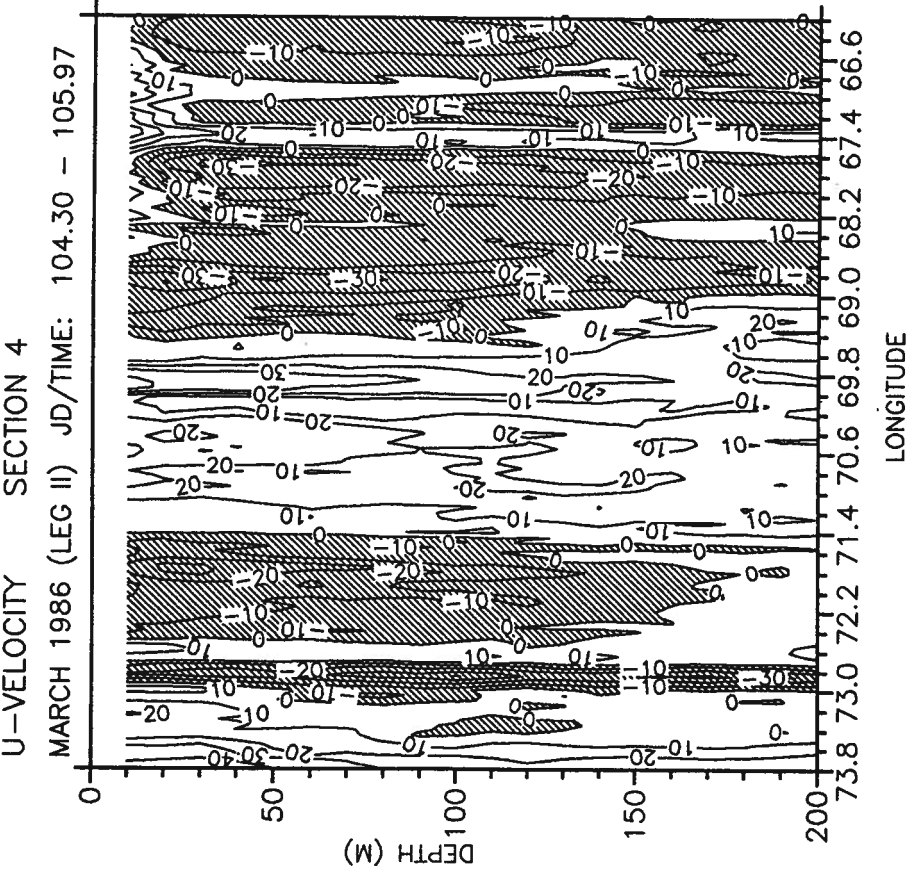

U-VELOCITY SECTION 5 (LORAN)

MARCH 1986 (LEG II) JD/TIME: 110.11 - 110.82

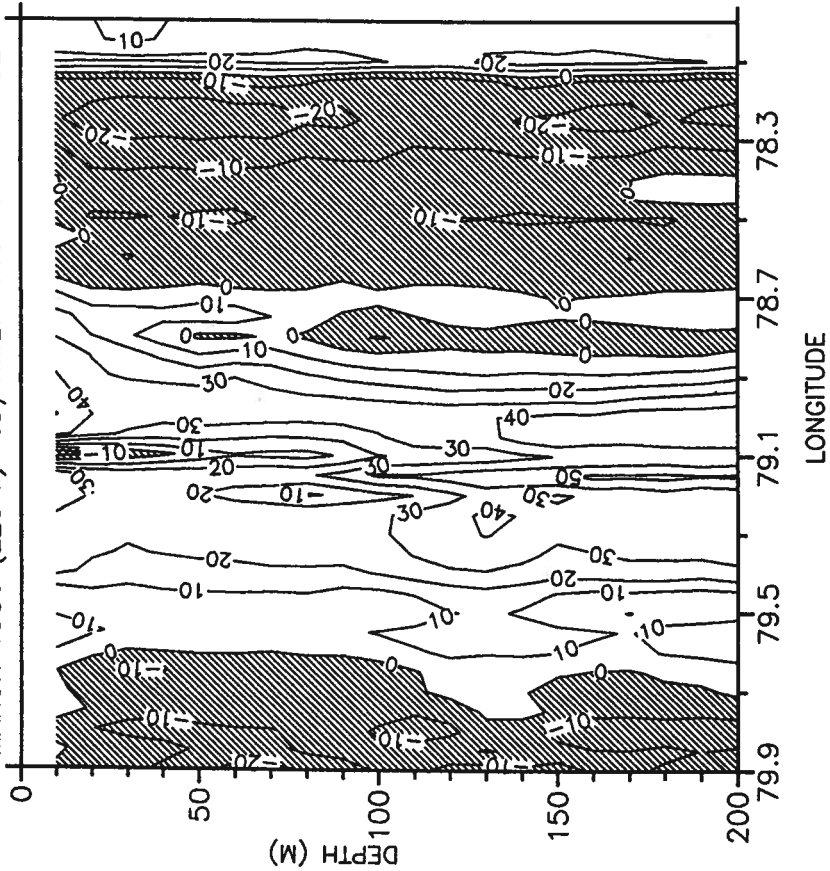

V-VELOCITY SECTION 5 (LORAN)

MARCH 1986 (LEG II) JD/TIME: 110.11 - 110.82

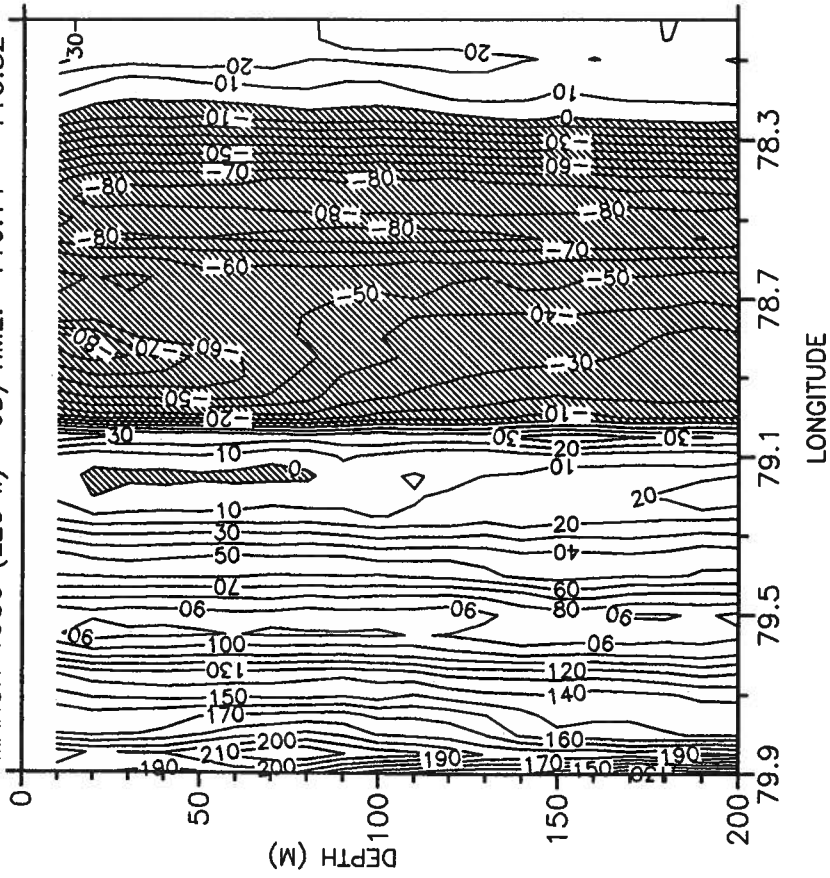





U-VELOCITY SECTION 6 (LORAN)

MARCH 1986 (LEG II) JD/TIME: 110.82 - 111.39

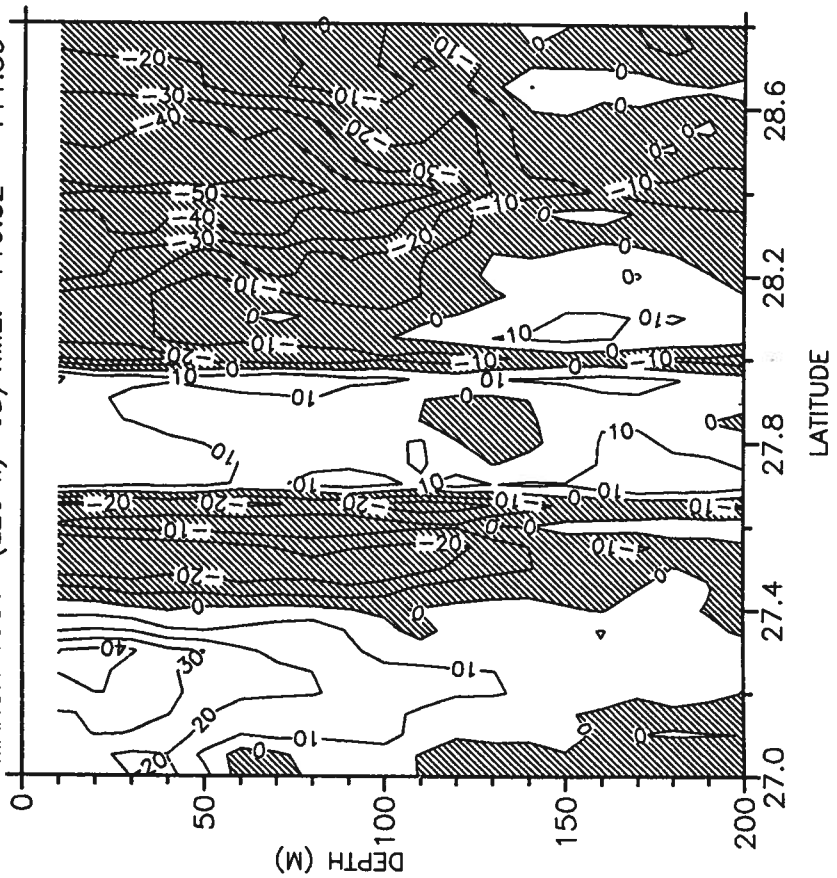

V-VELOCITY SECTION 6 (LORAN)

MARCH 1986 (LEG II) JD/TIME: 110.82 - 111.39

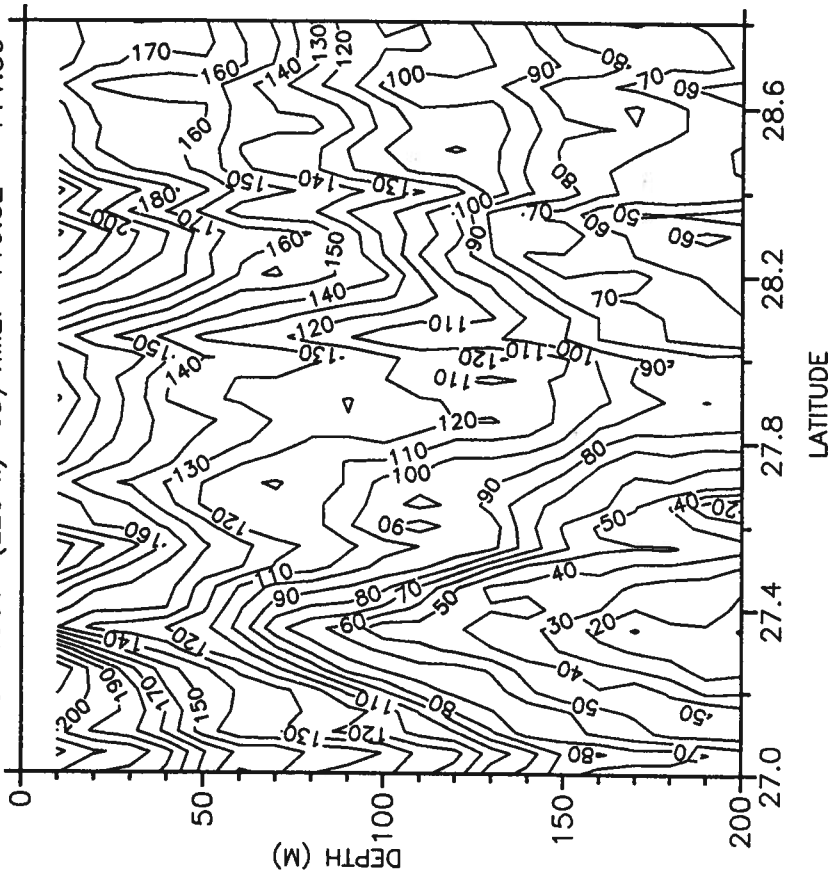

U-VELOCITY SECTION 7 (LORAN)

MARCH 1986 (LEG II) JD/TIME: 111.39 - 111.85

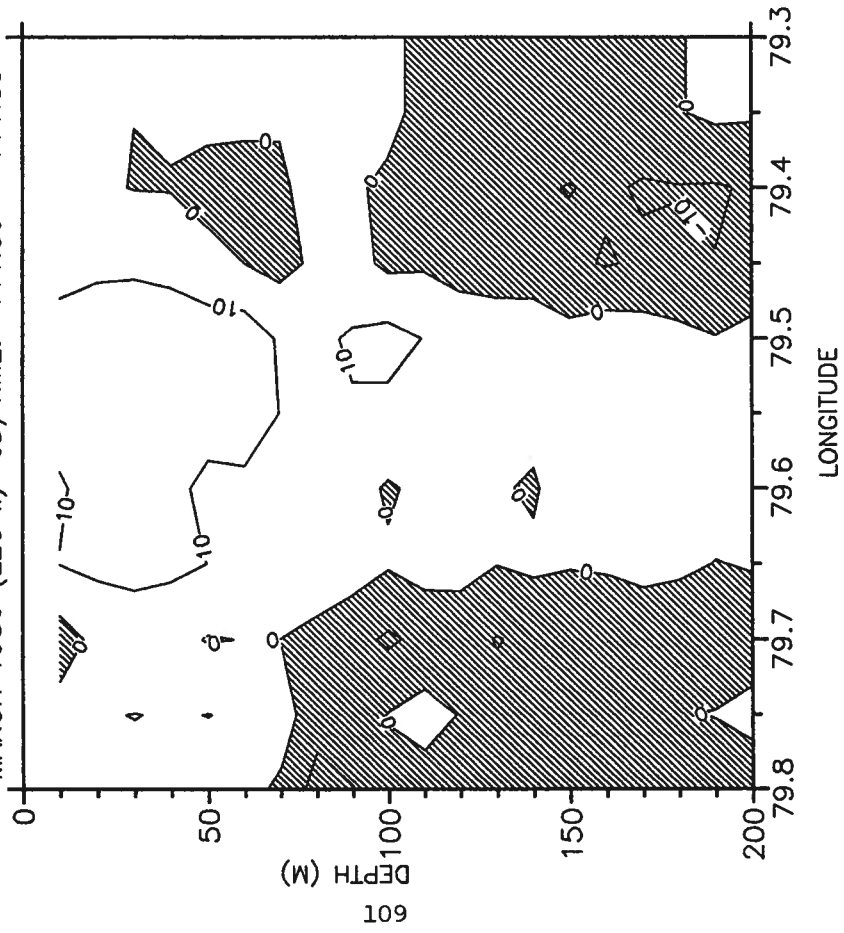

V-VELOCITY SECTION 7 (LORAN)

MARCH 1986 (LEG II) JD/TIME: 111.39 - 111.85

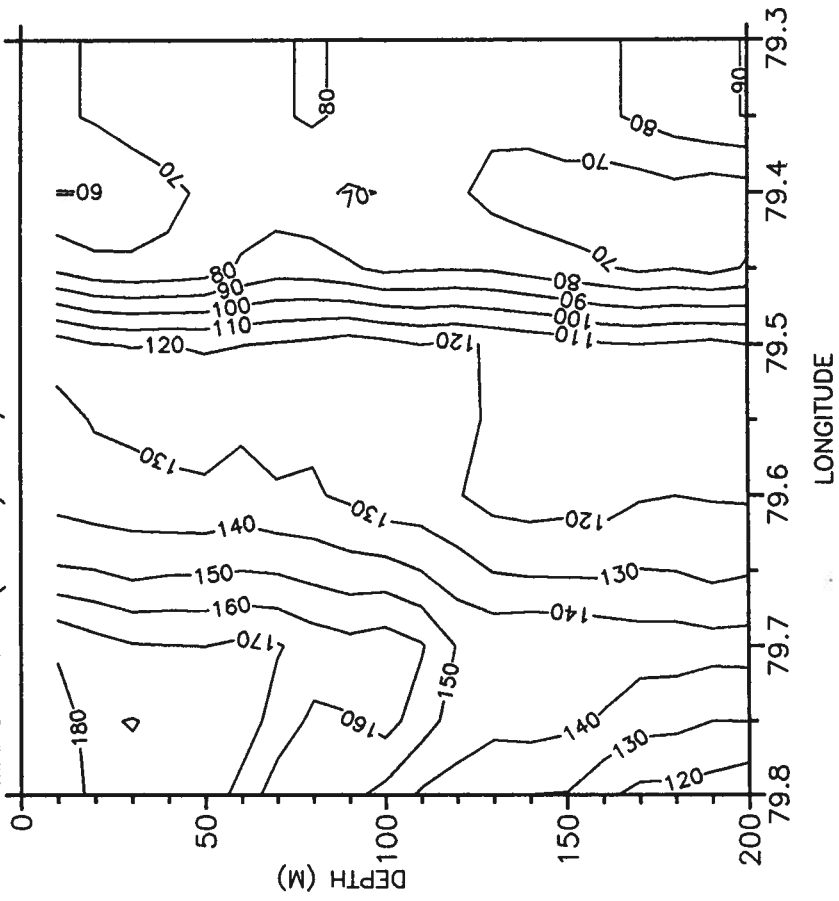

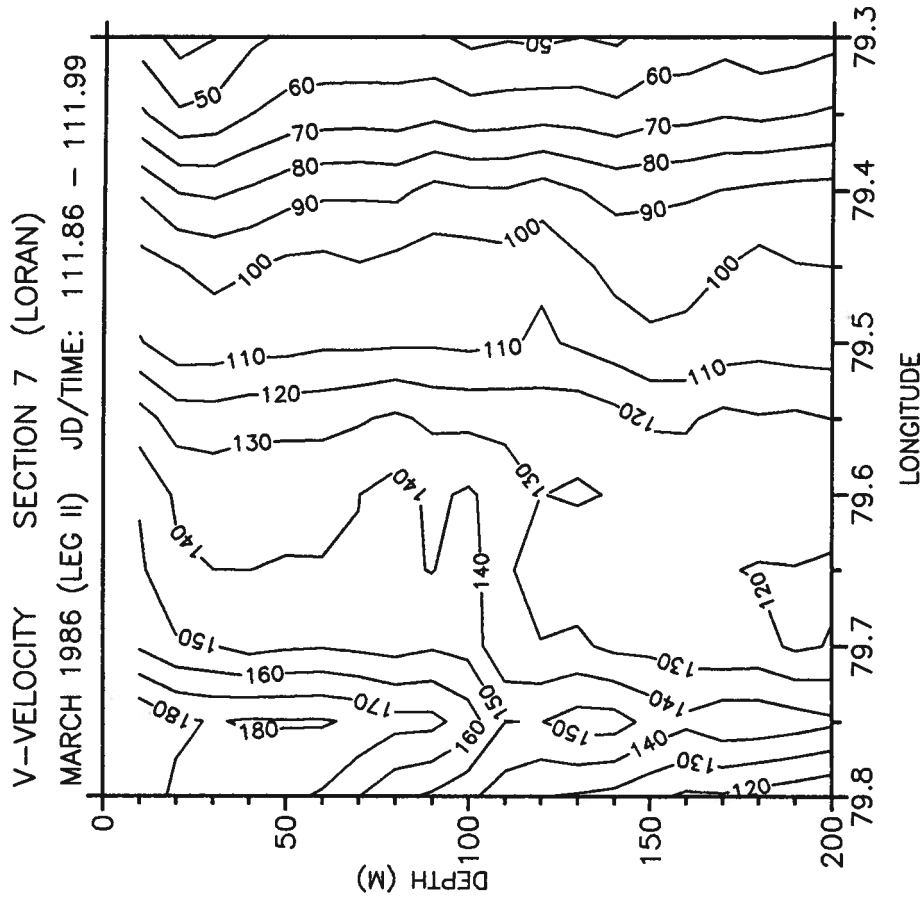
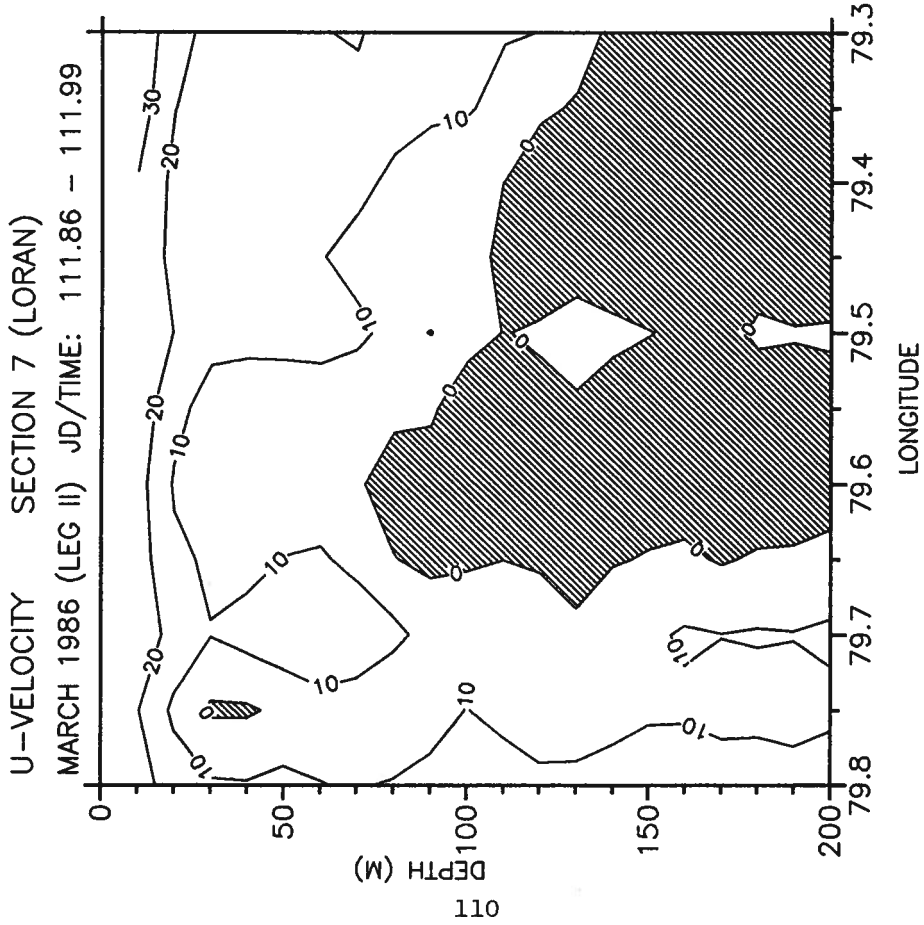

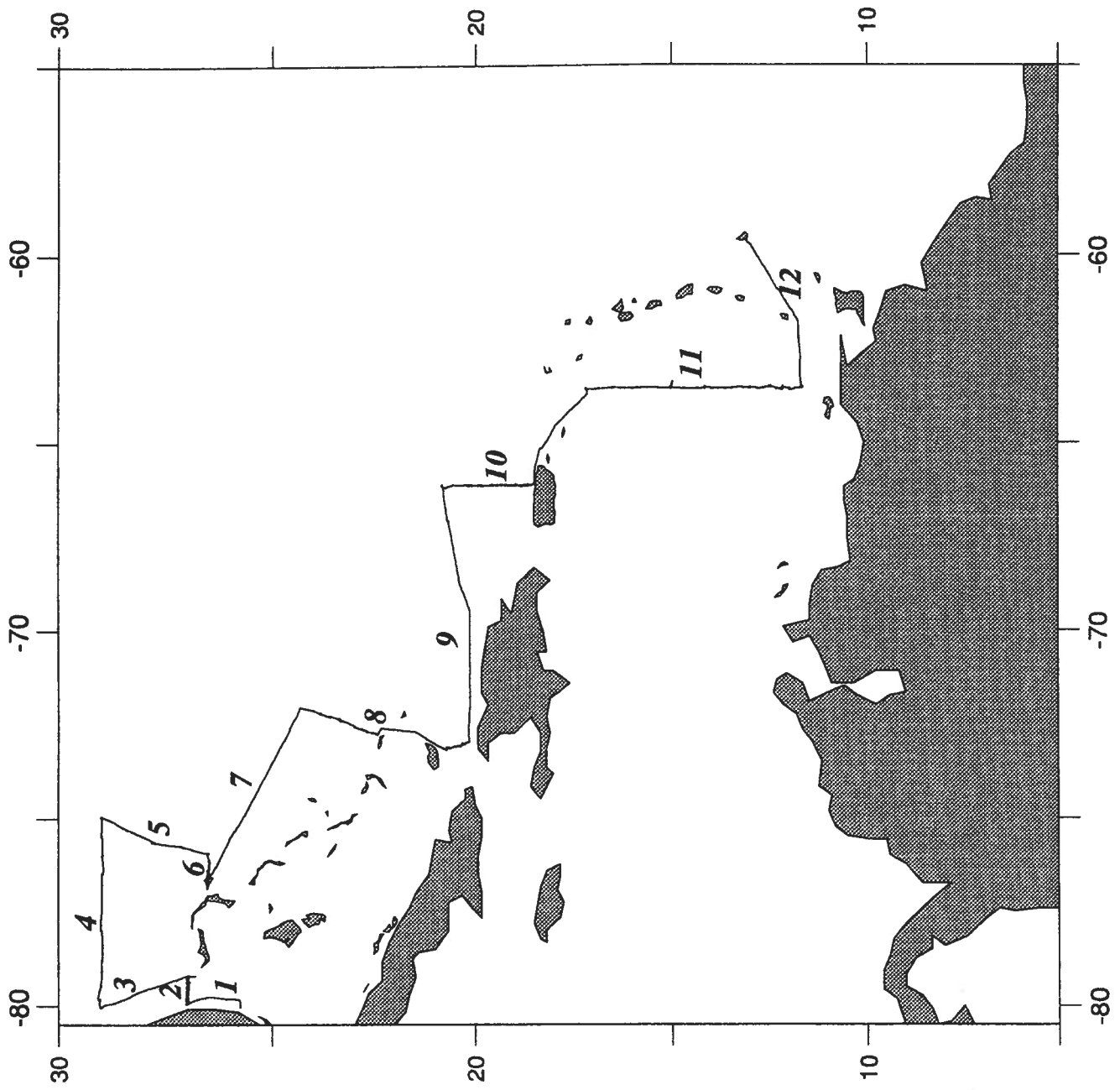

*Map of the Ametek-Straza (ADCP) trackline - July 1986*

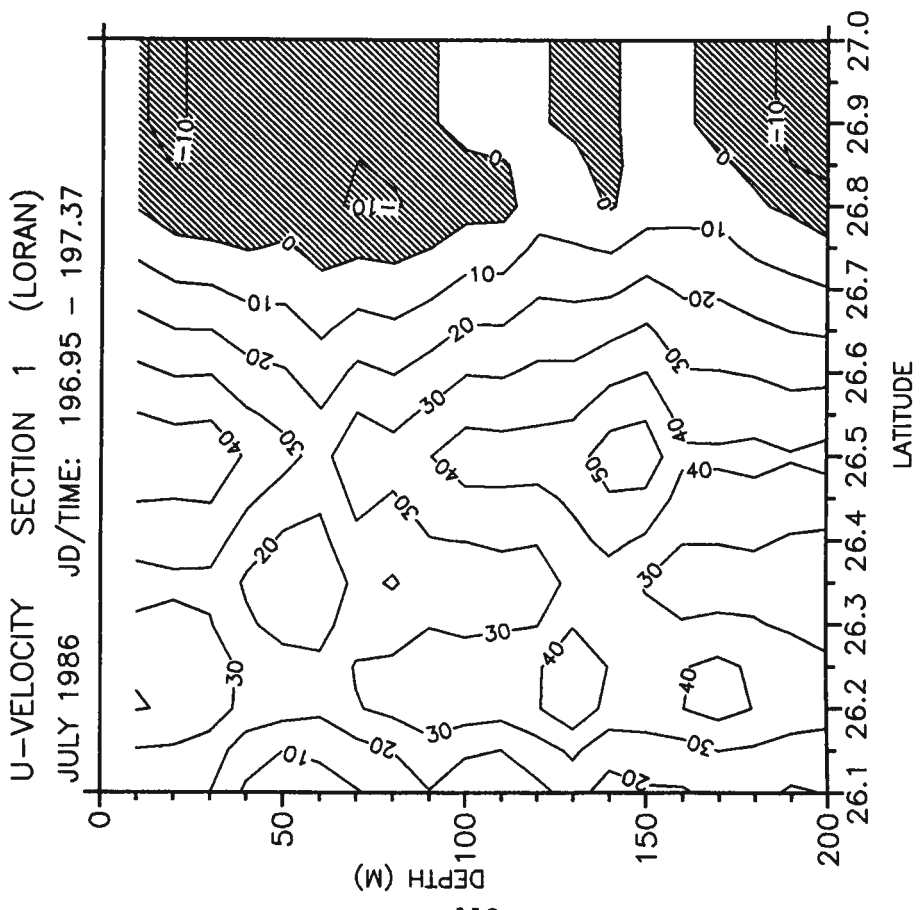
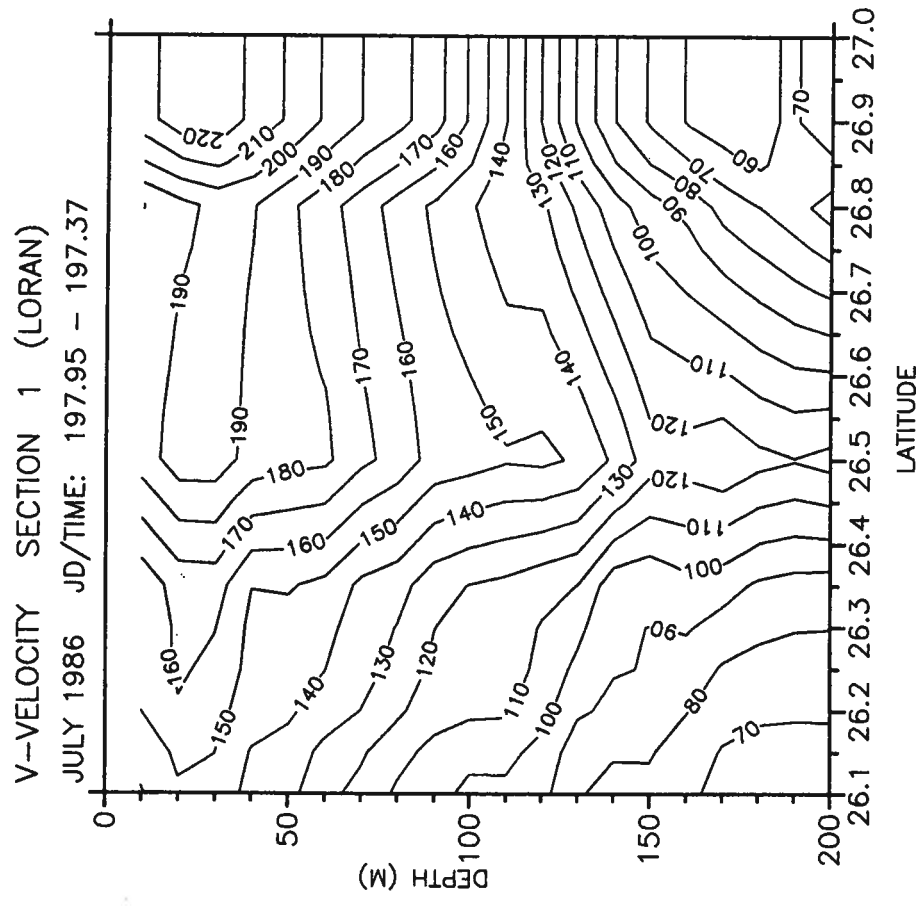

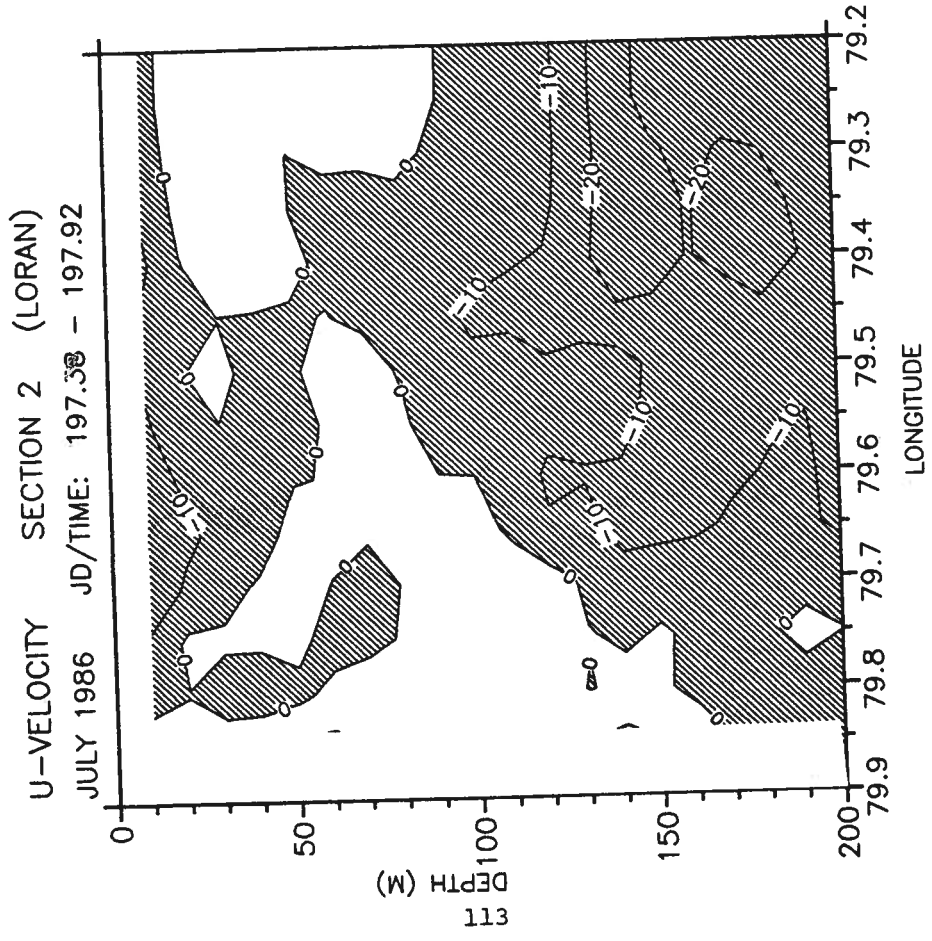
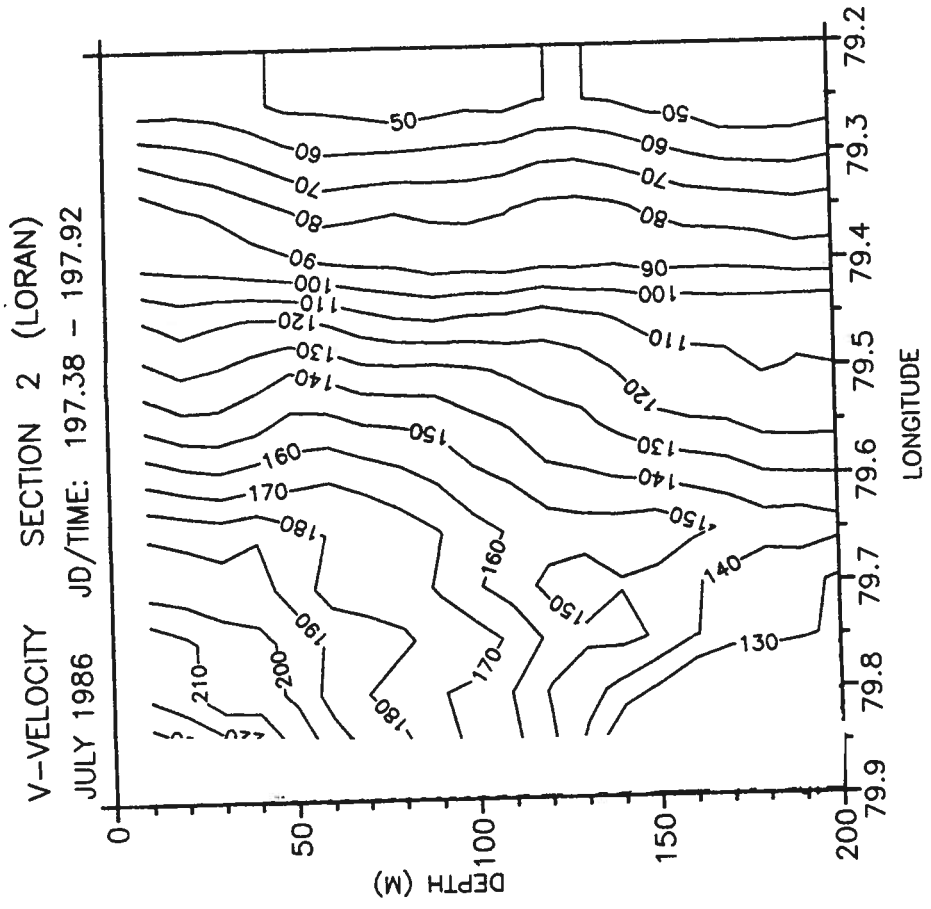

U-VELOCITY SECTION 2 (LORAN)  
 JULY 1986 JD/TIME: 197.93 - 198.55

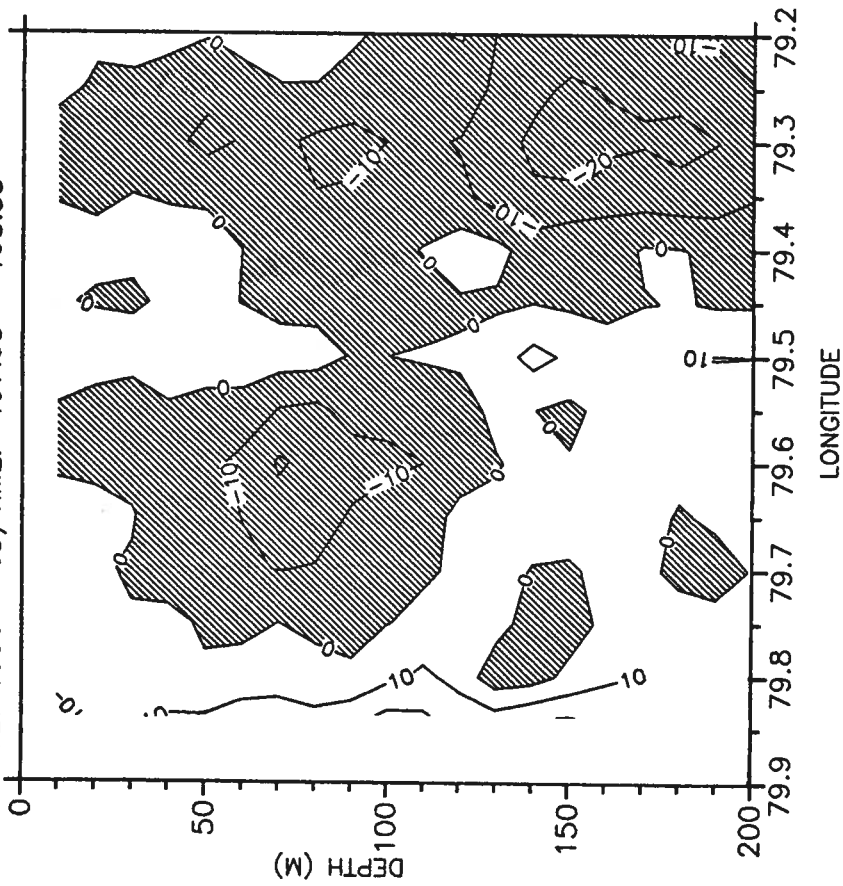

V-VELOCITY SECTION 2 (LORAN)  
 JULY 1986 JD/TIME: 197.93 - 198.55

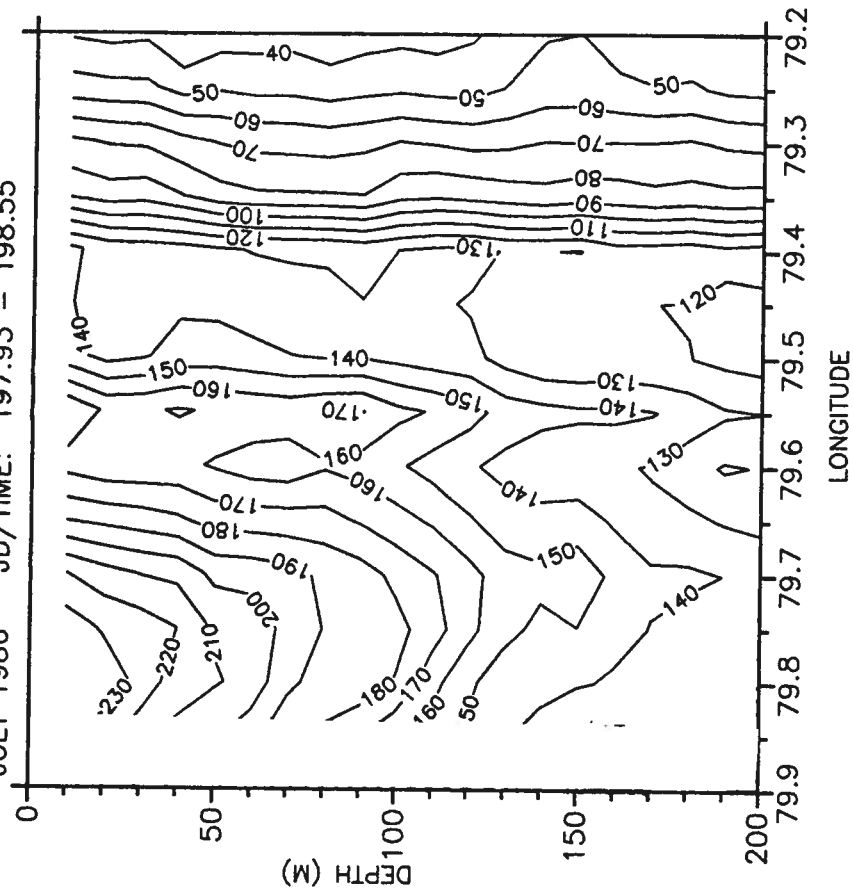

V-VELOCITY SECTION 2 (LORAN)  
 JULY 1986 JD/TIME: 198.56 - 199.12

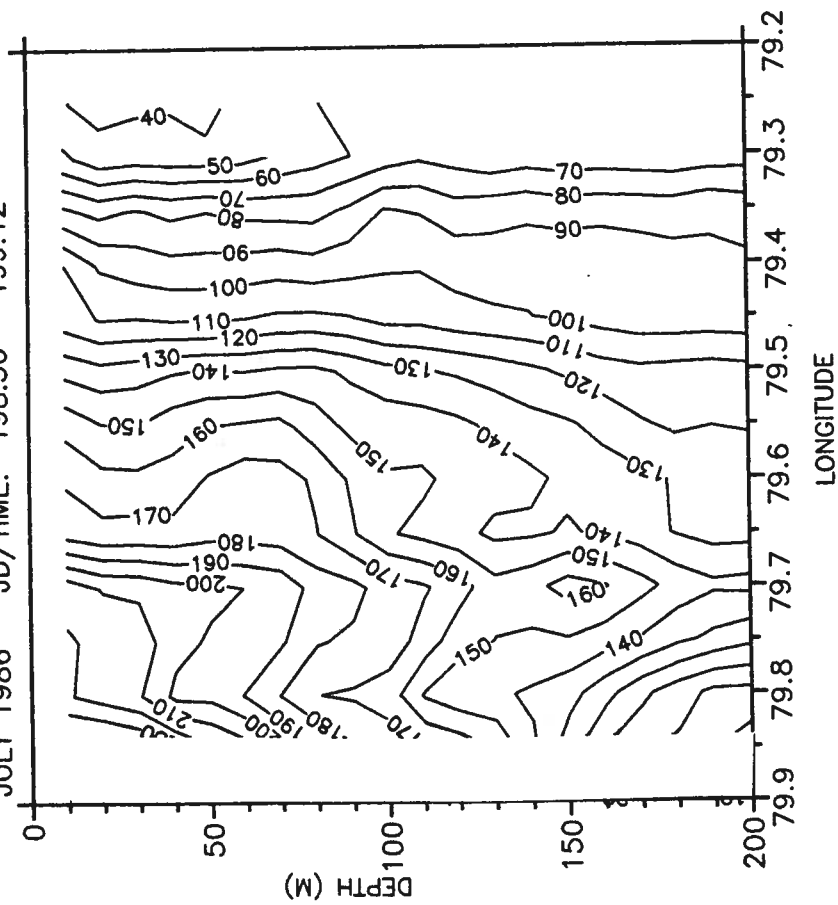

U-VELOCITY SECTION 2 (LORAN)  
 JULY 1986 JD/TIME: 198.56 - 199.12

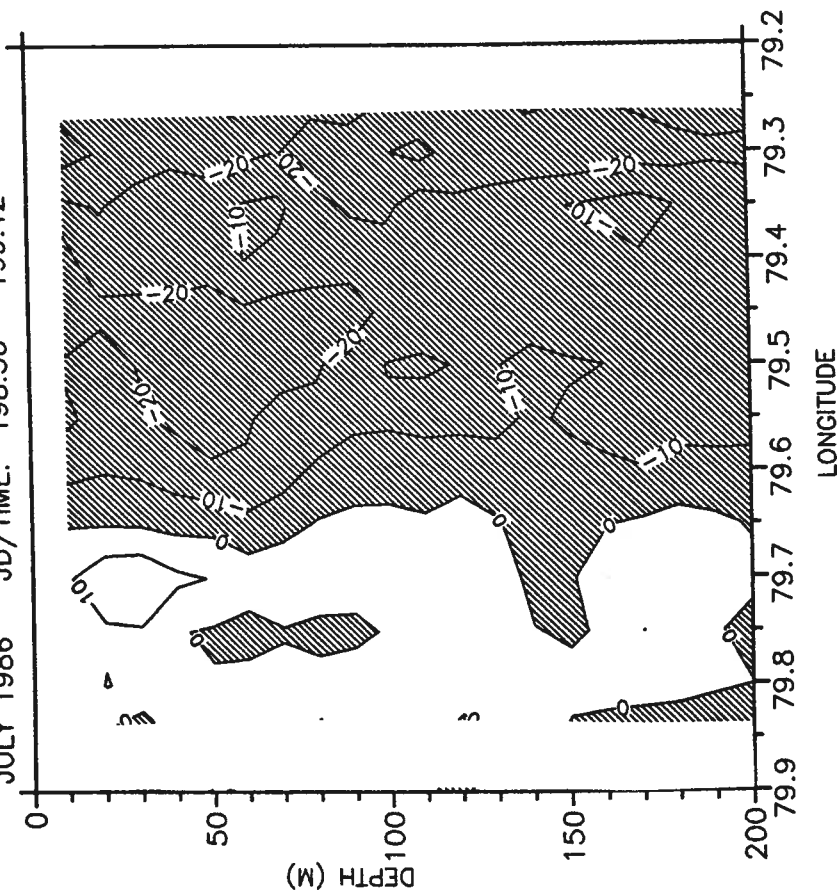



U-VELOCITY SECTION 3 (LORAN)  
JULY 1986 JD/TIME: 199.13 - 199.53

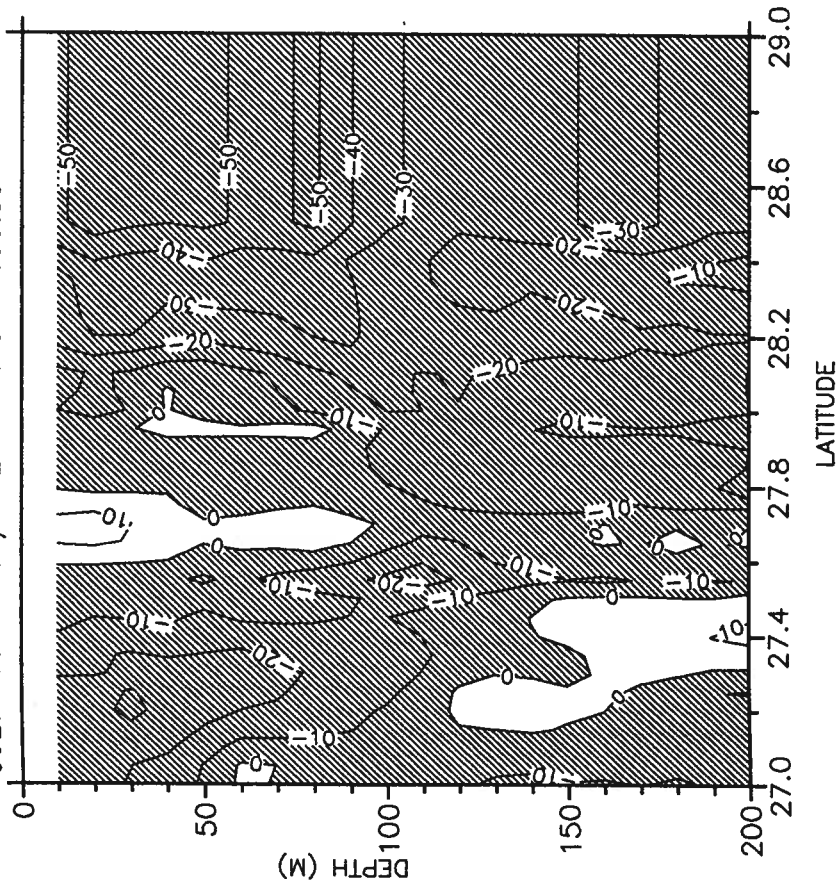

V-VELOCITY SECTION 3 (LORAN)  
JULY 1986 JD/TIME: 199.13 - 199.53

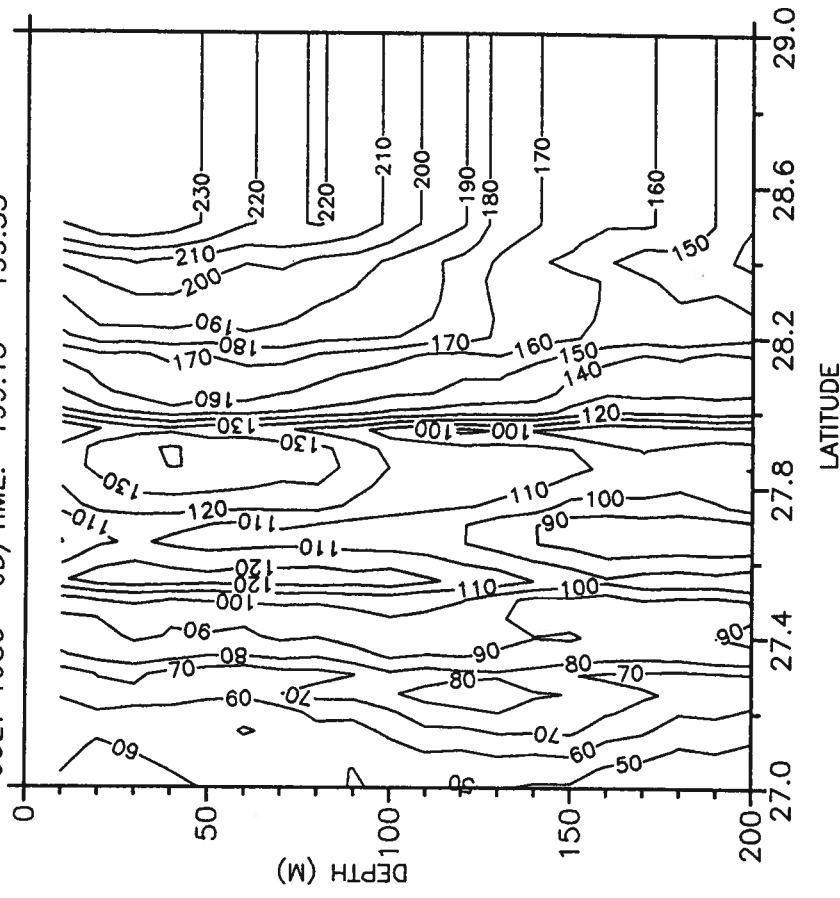

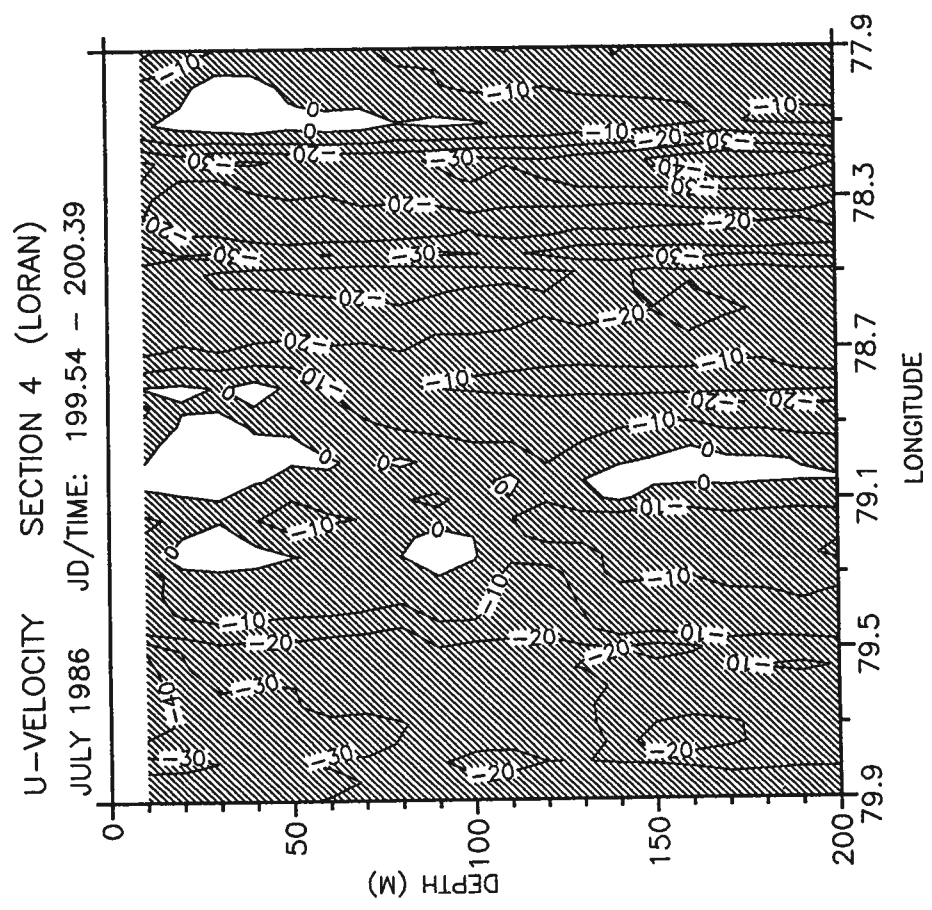
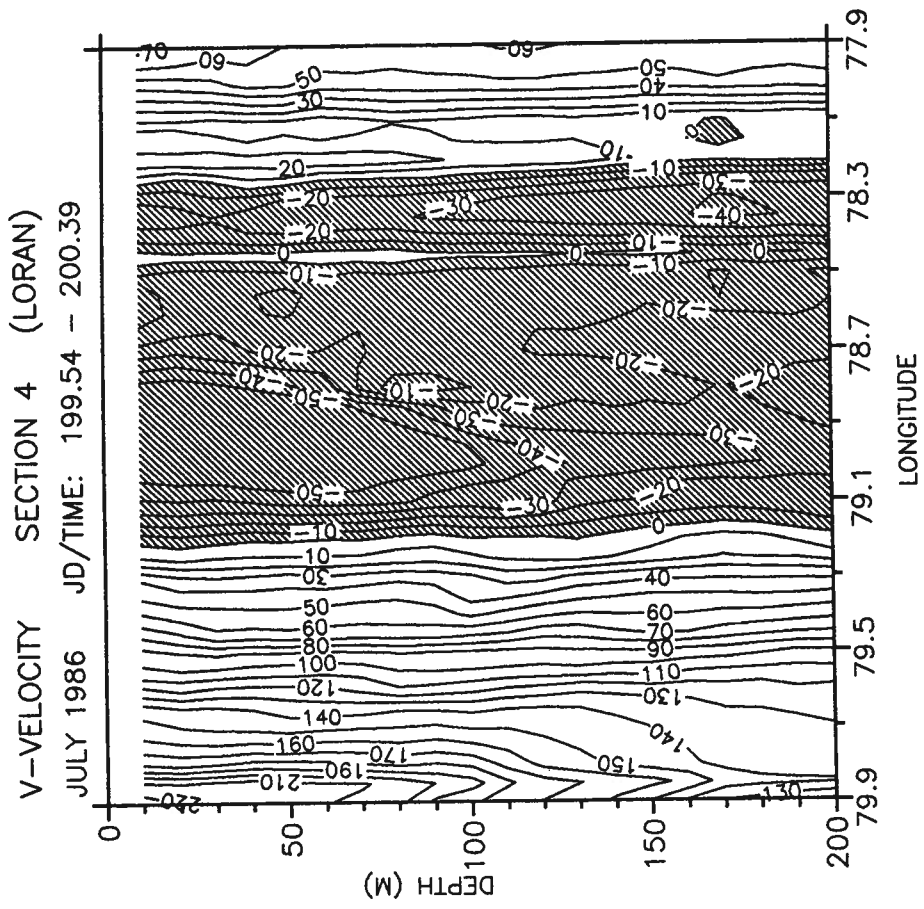

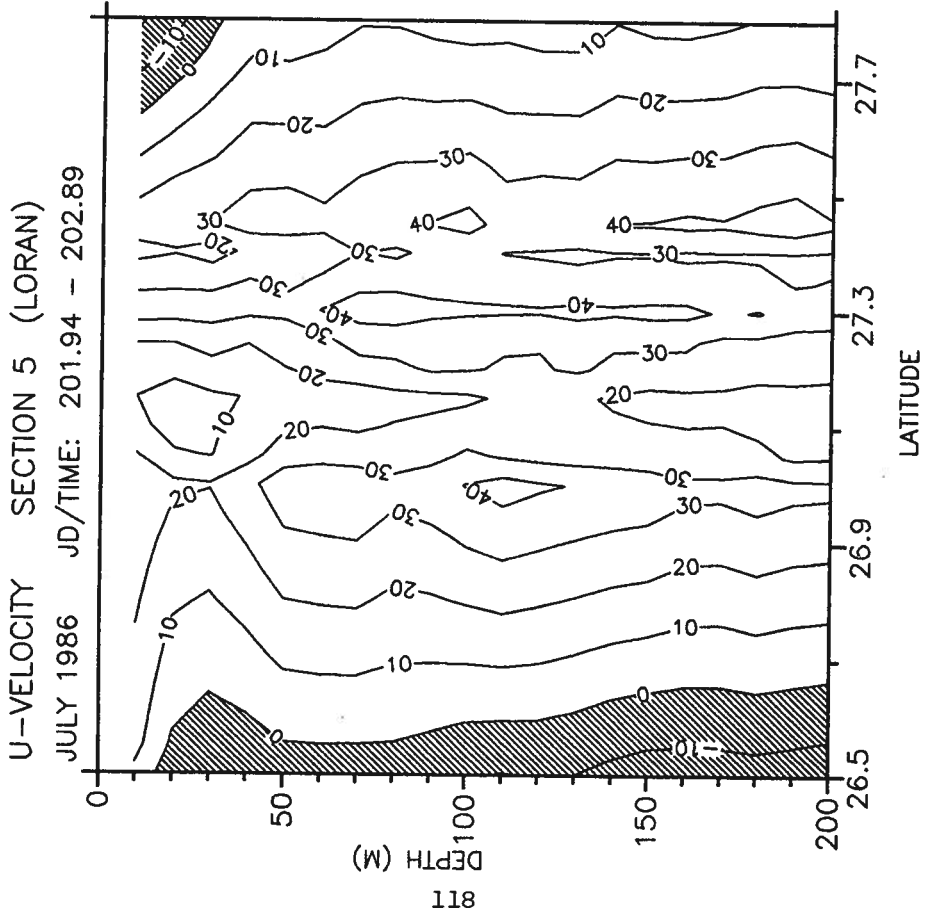
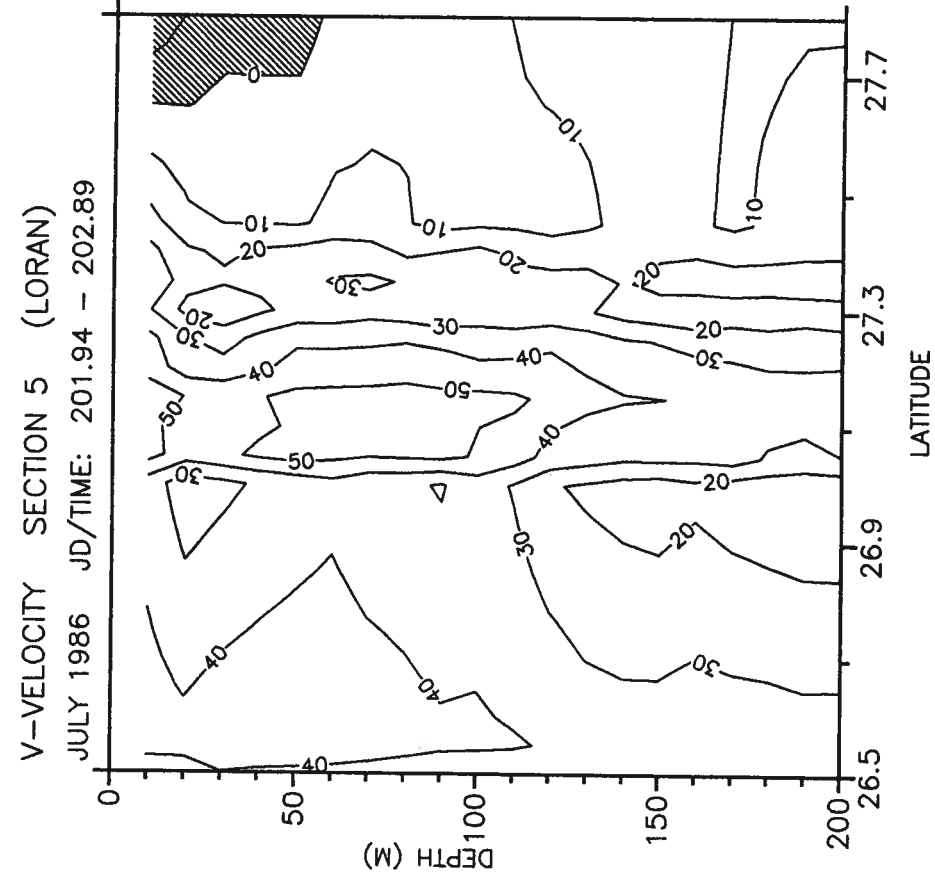

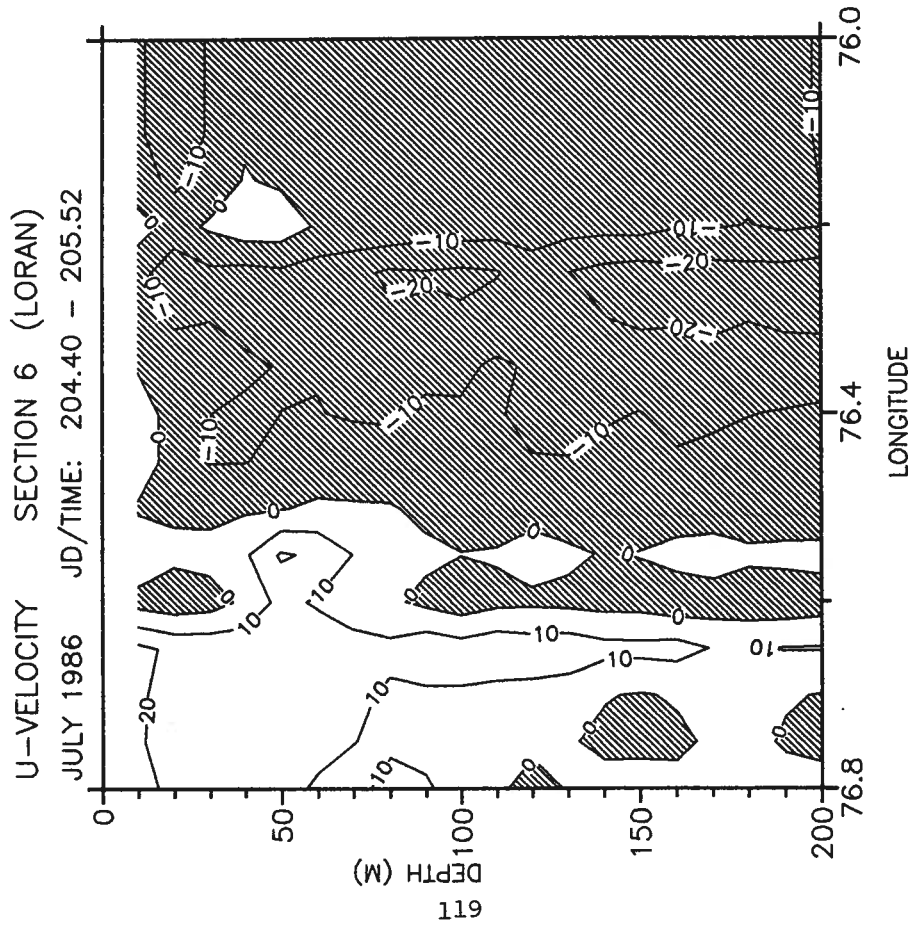
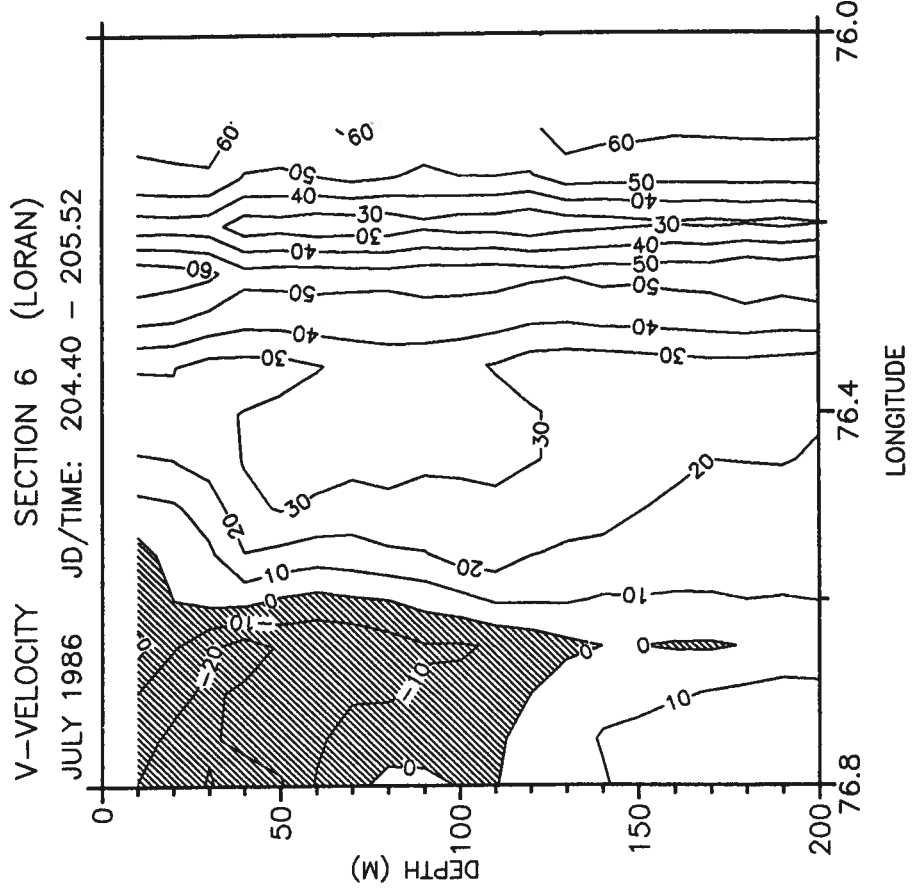

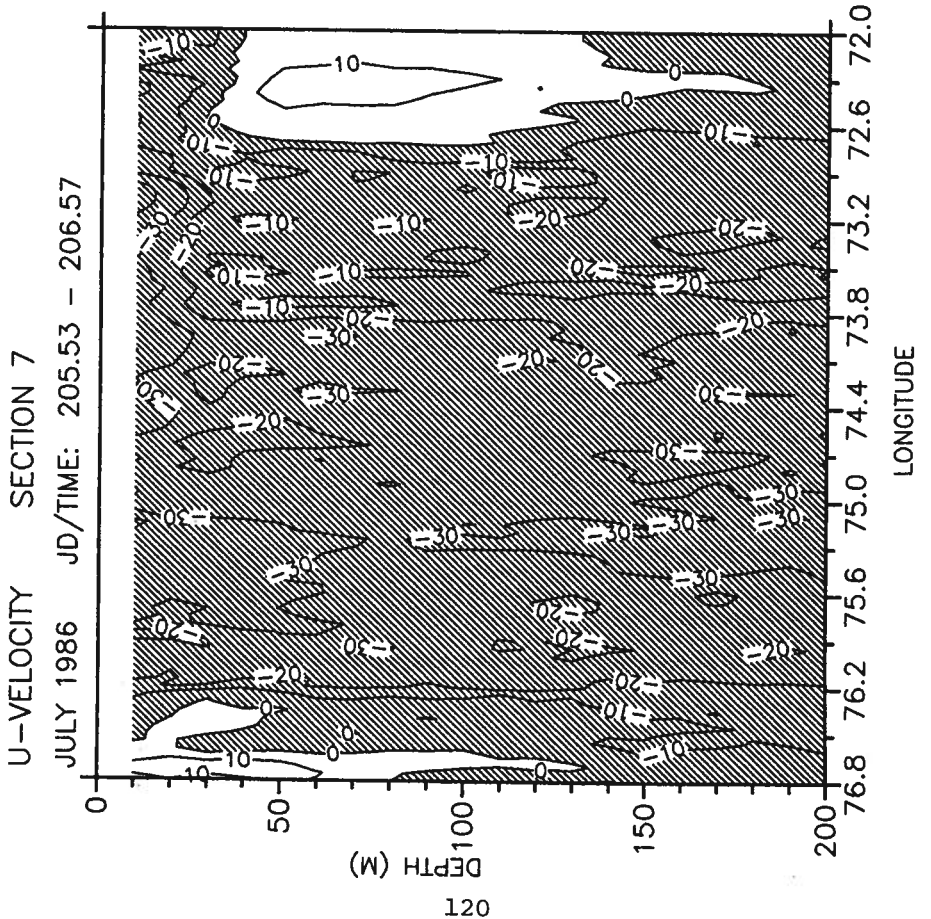
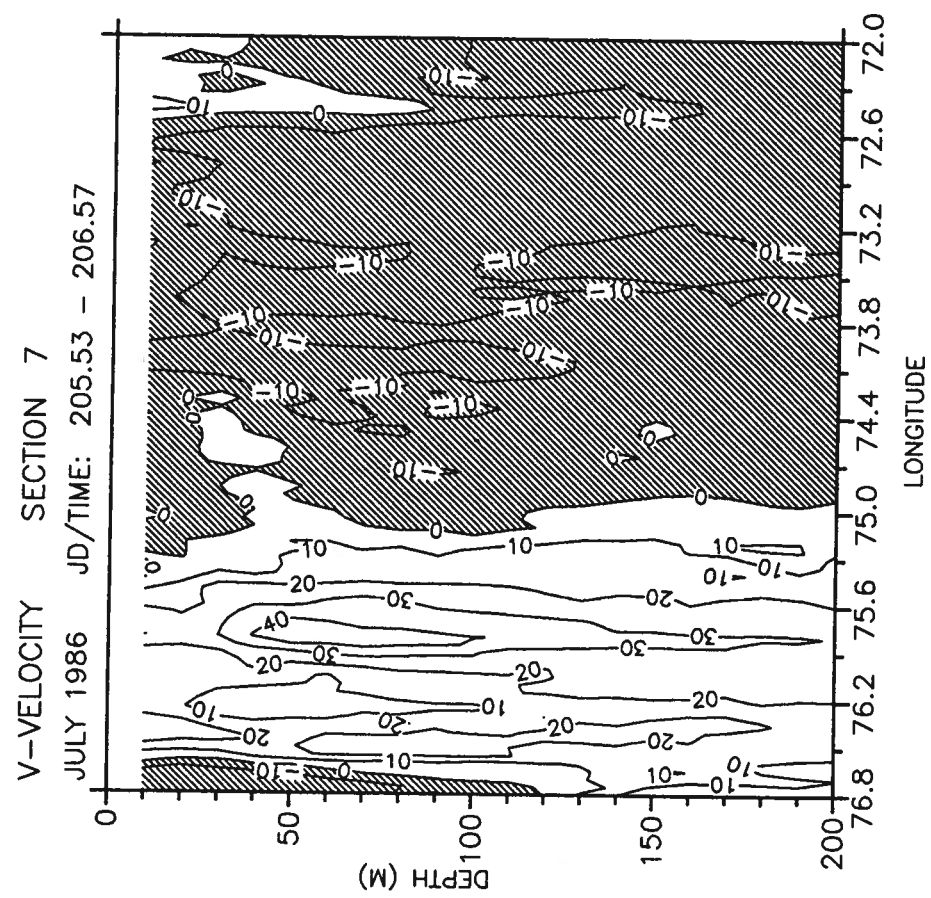

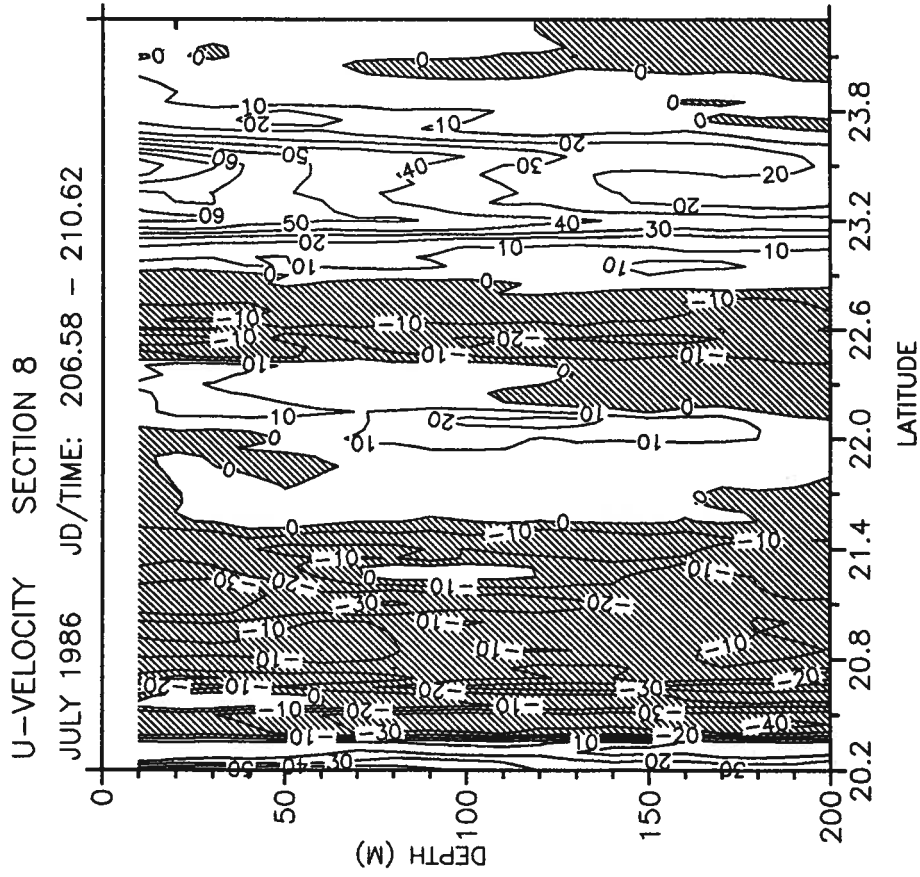
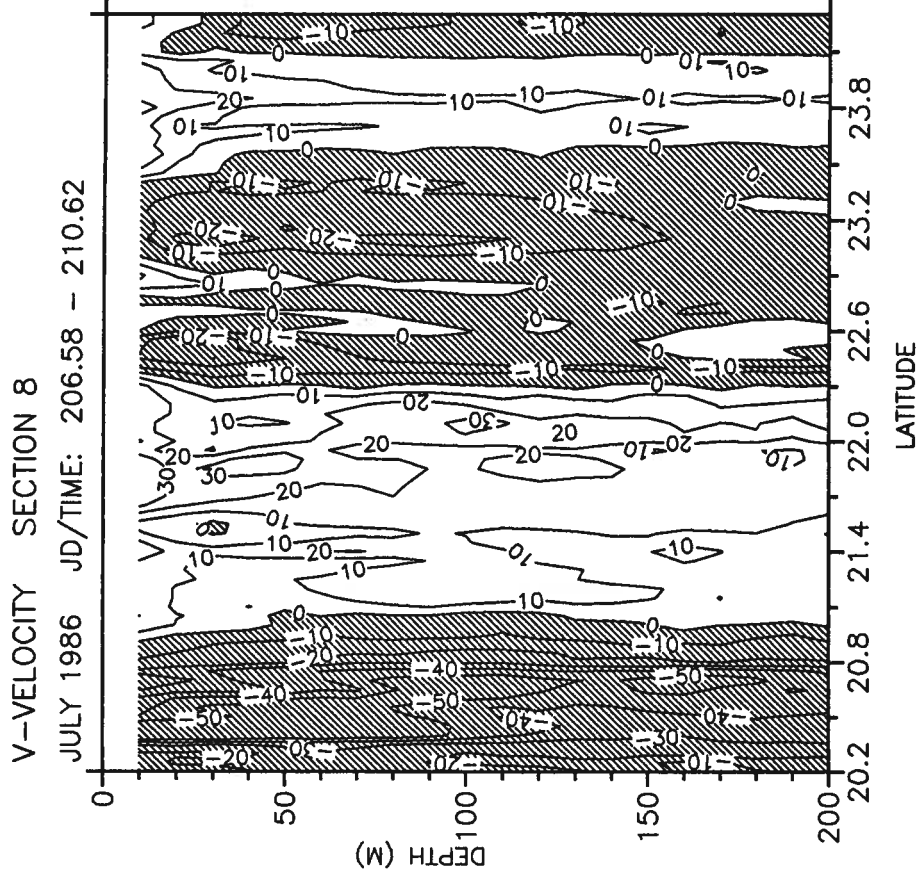

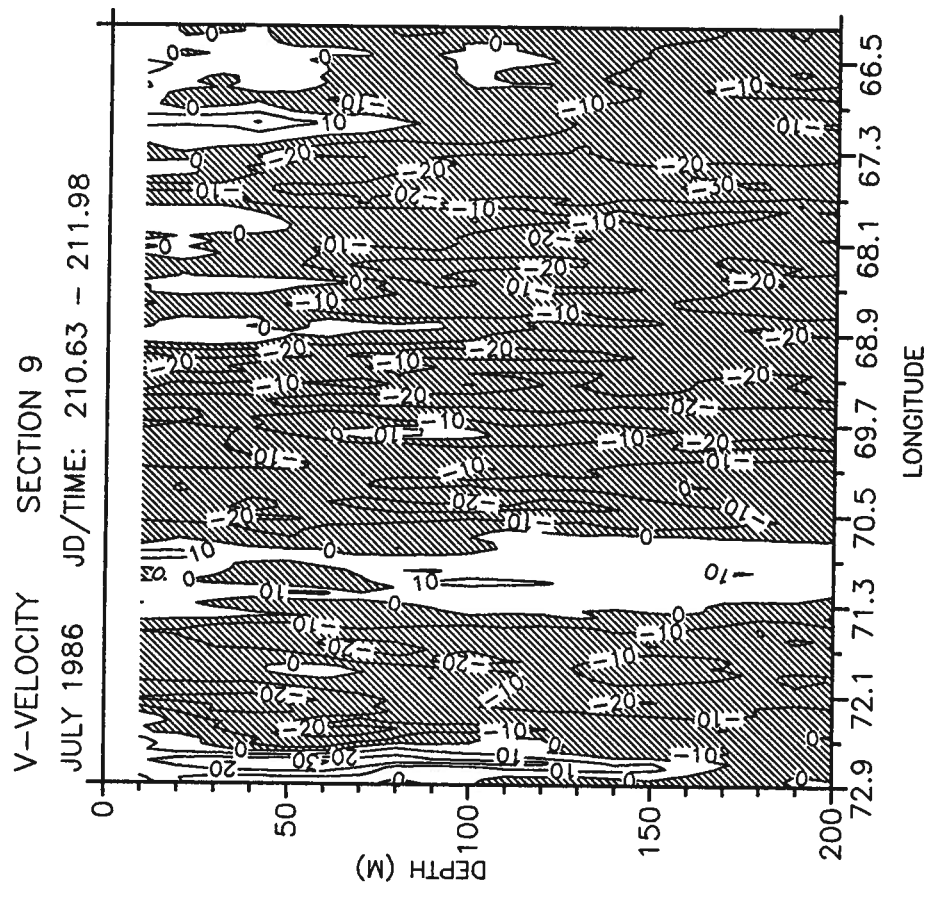
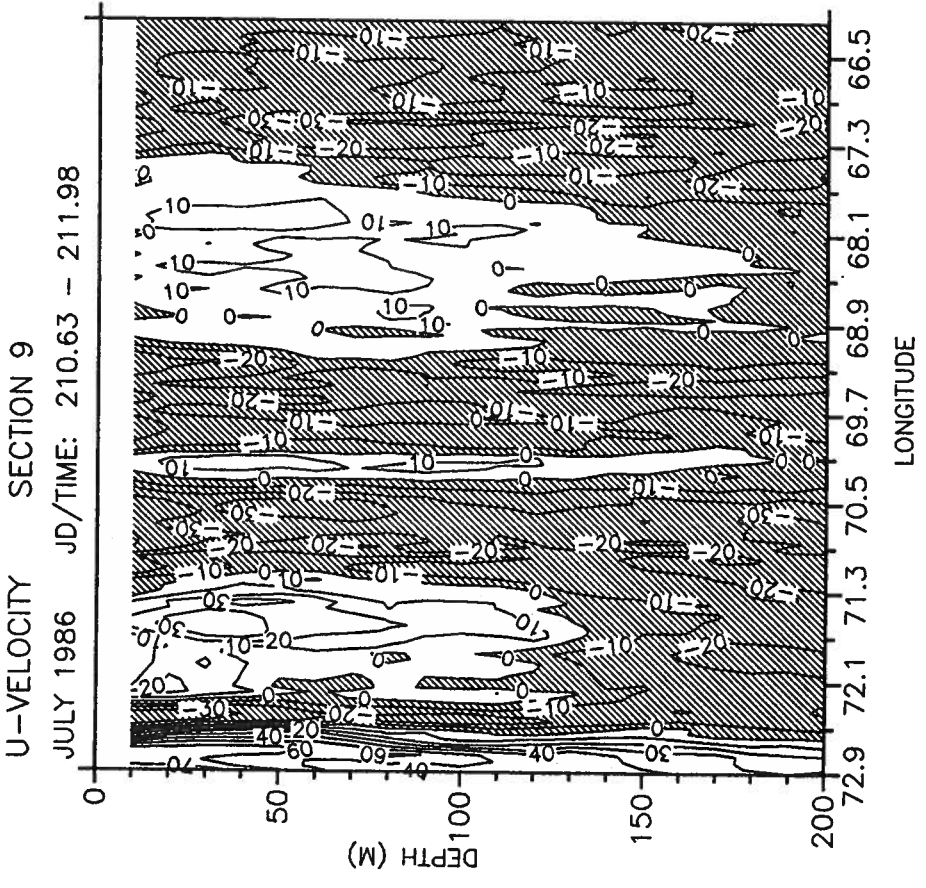

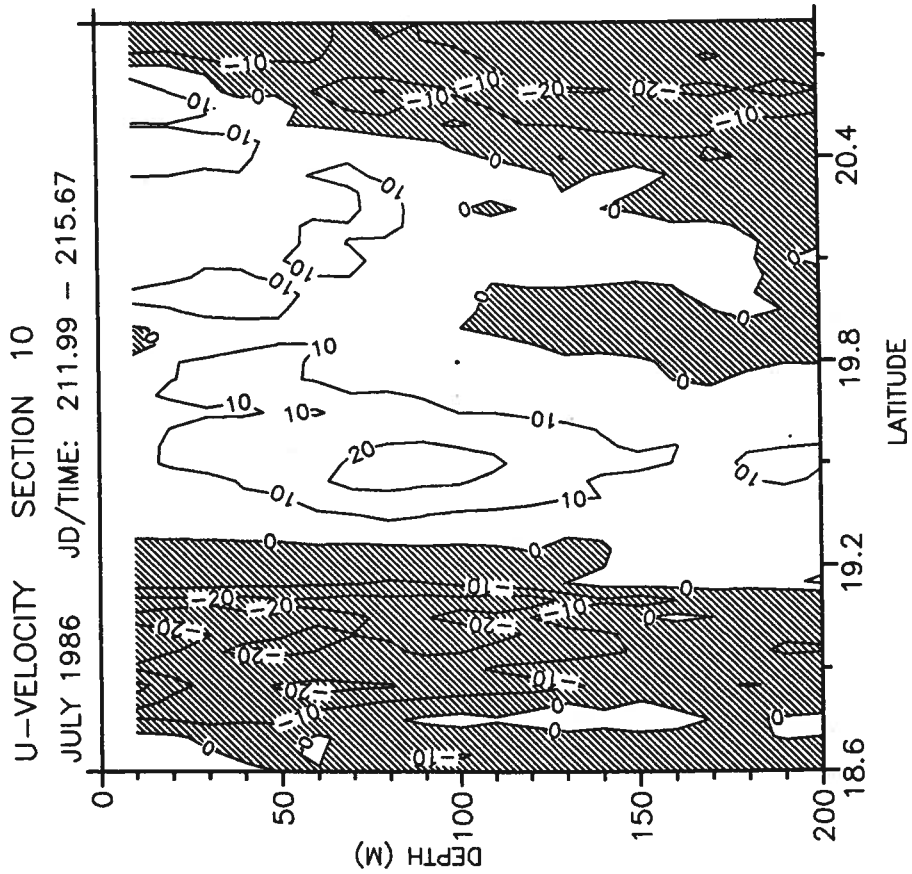
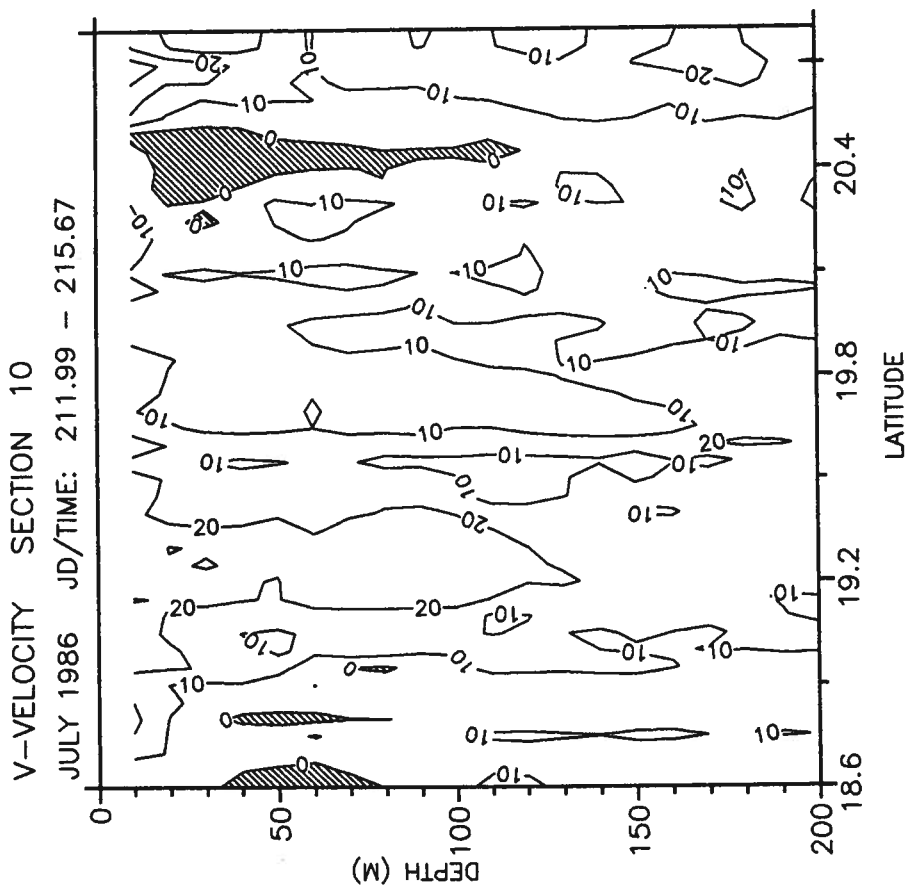



V-VELOCITY SECTION 11

JULY 1986 JD/TIME: 216.32 - 219.64

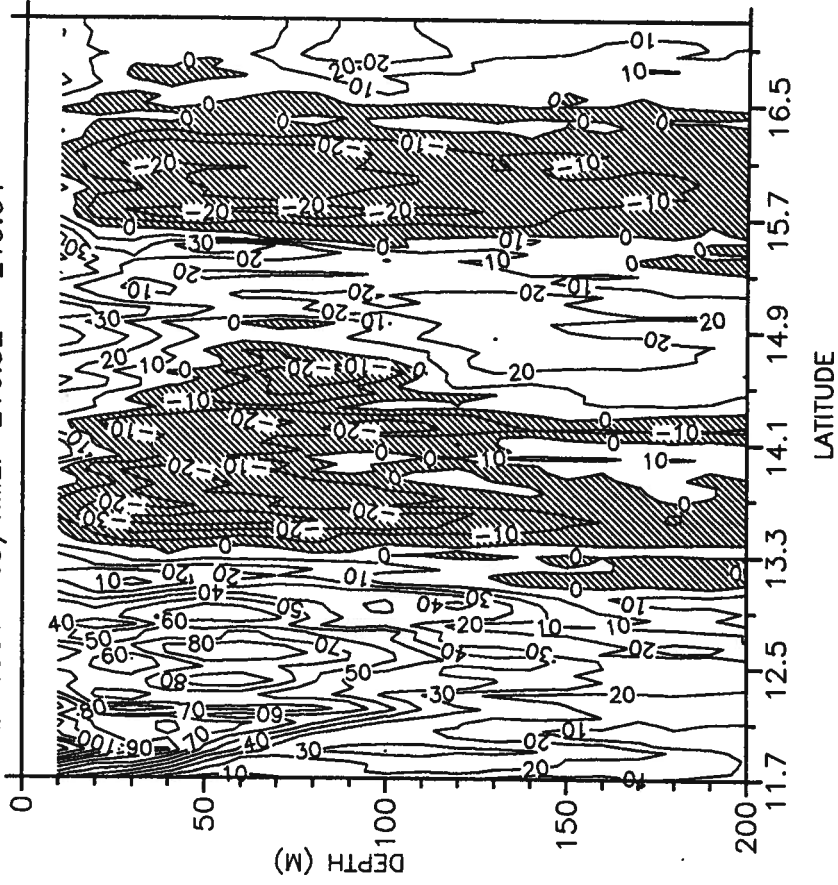

U-VELOCITY SECTION 11

JULY 1986 JD/TIME: 216.32 - 219.64

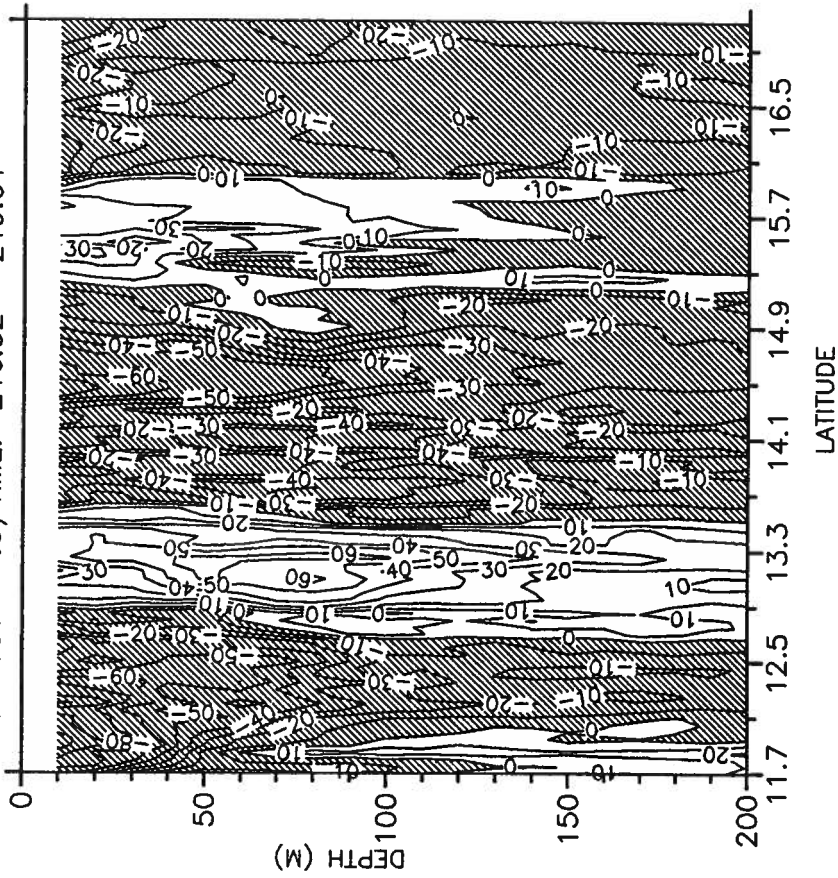

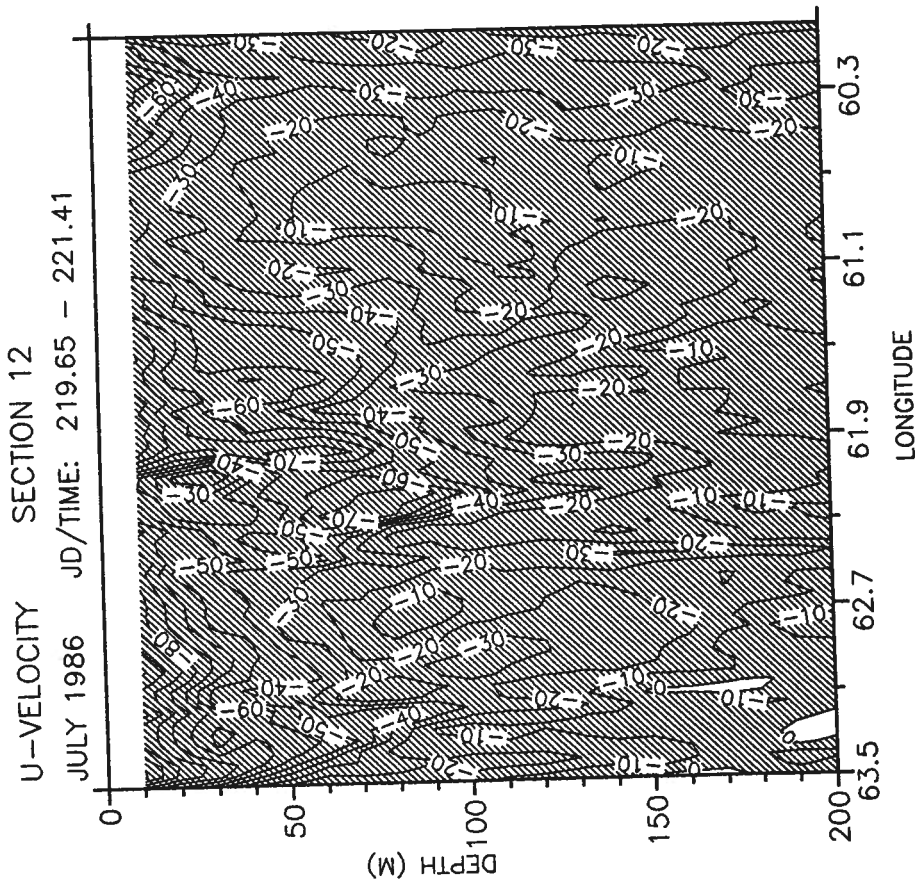
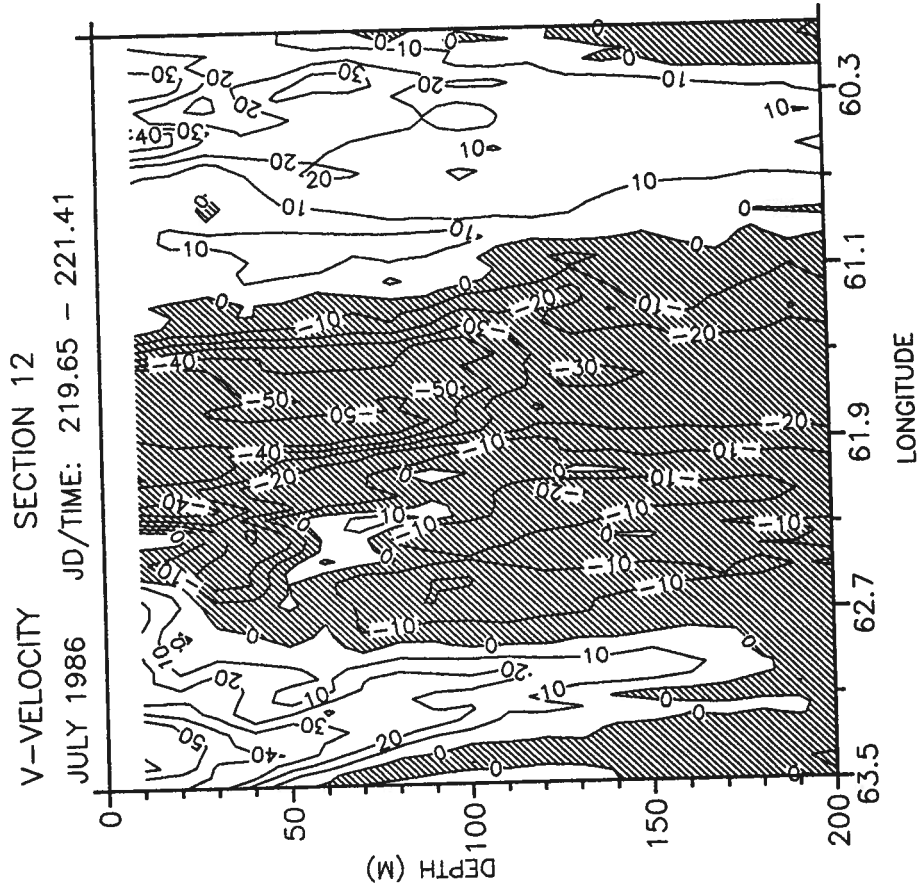

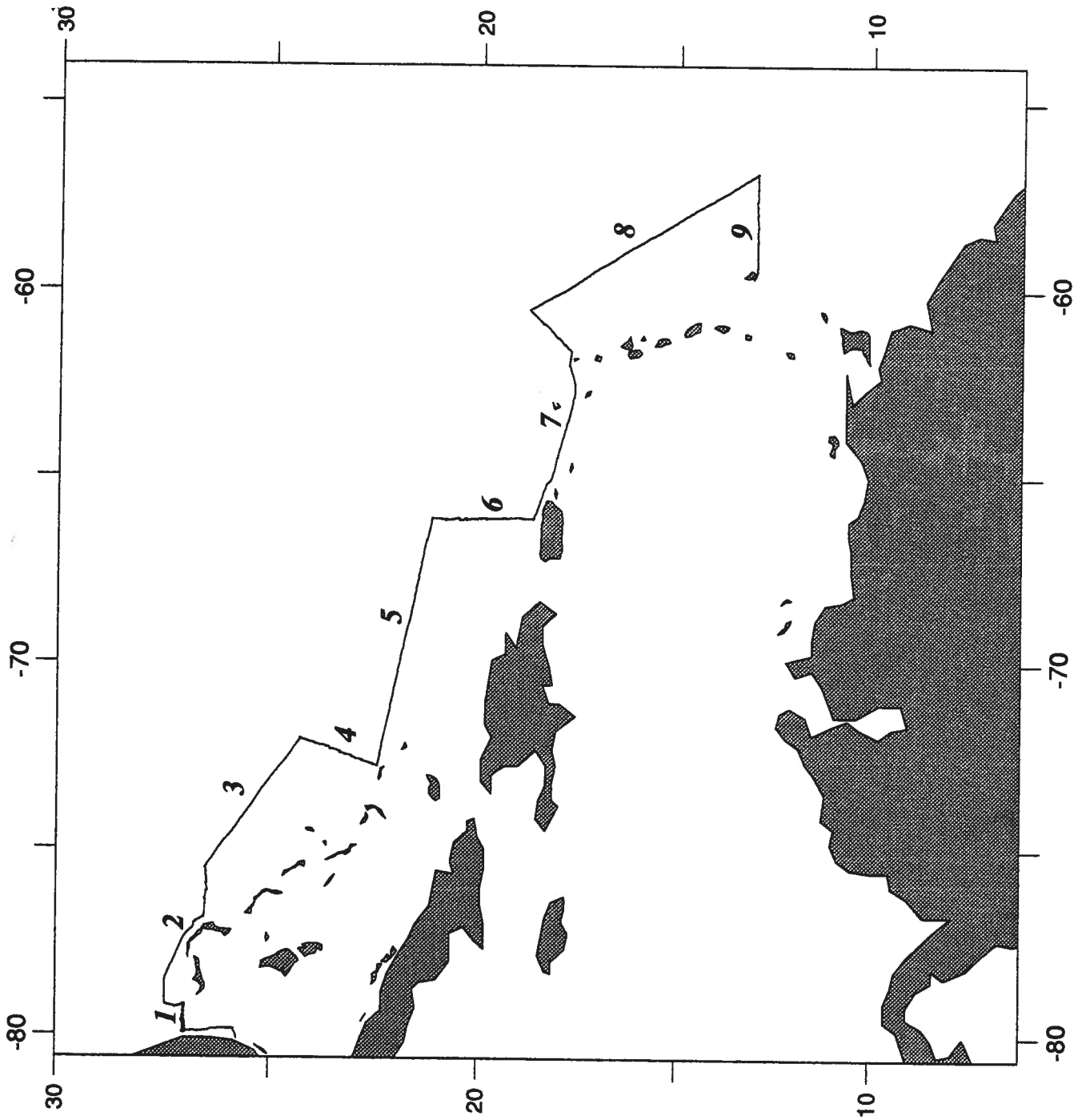

*Map of the Ametek-Straza (ADCP) trackline - October 1986 (Leg I)*

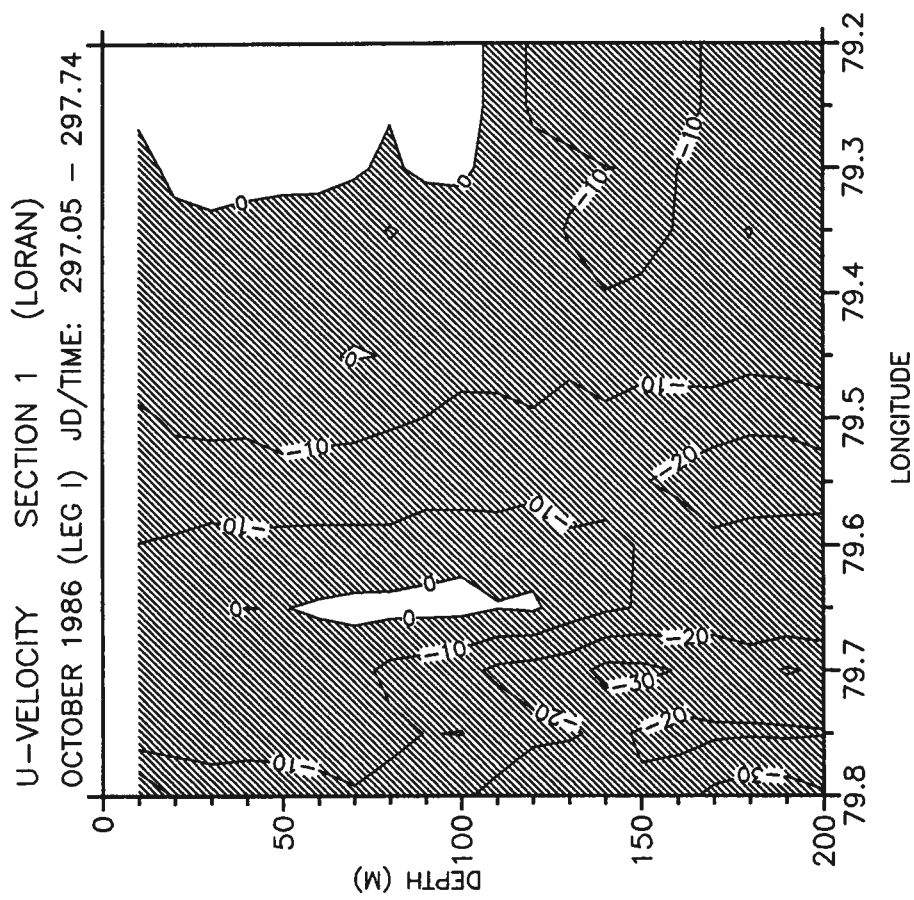
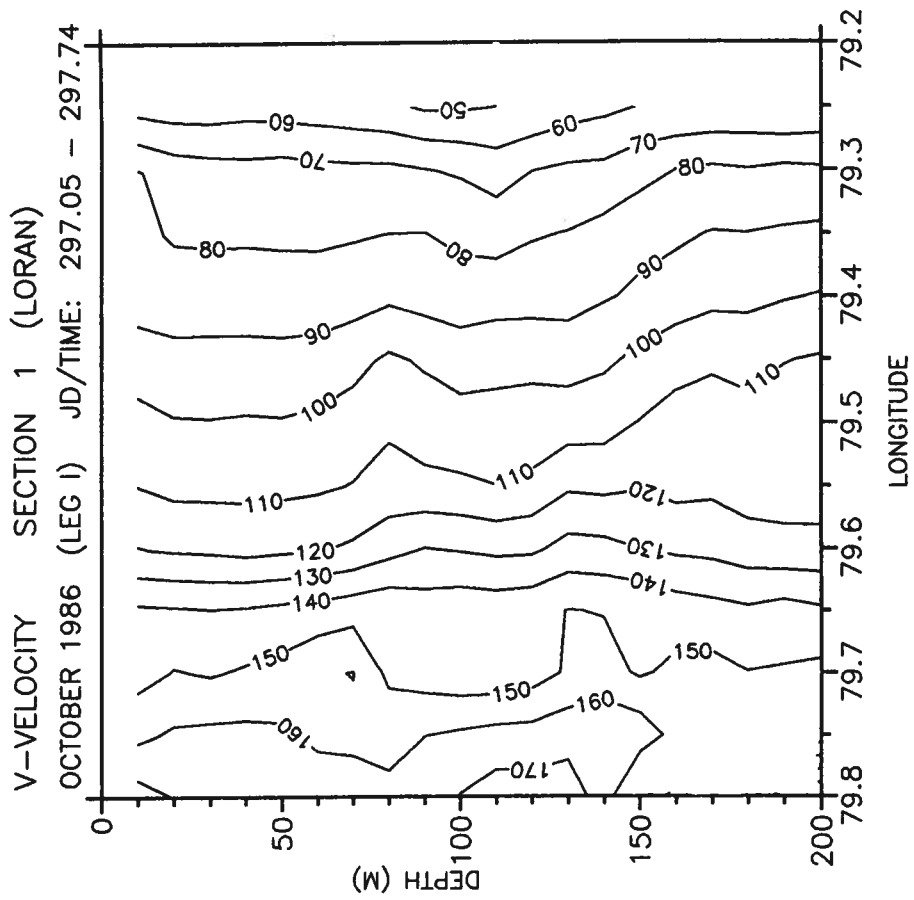

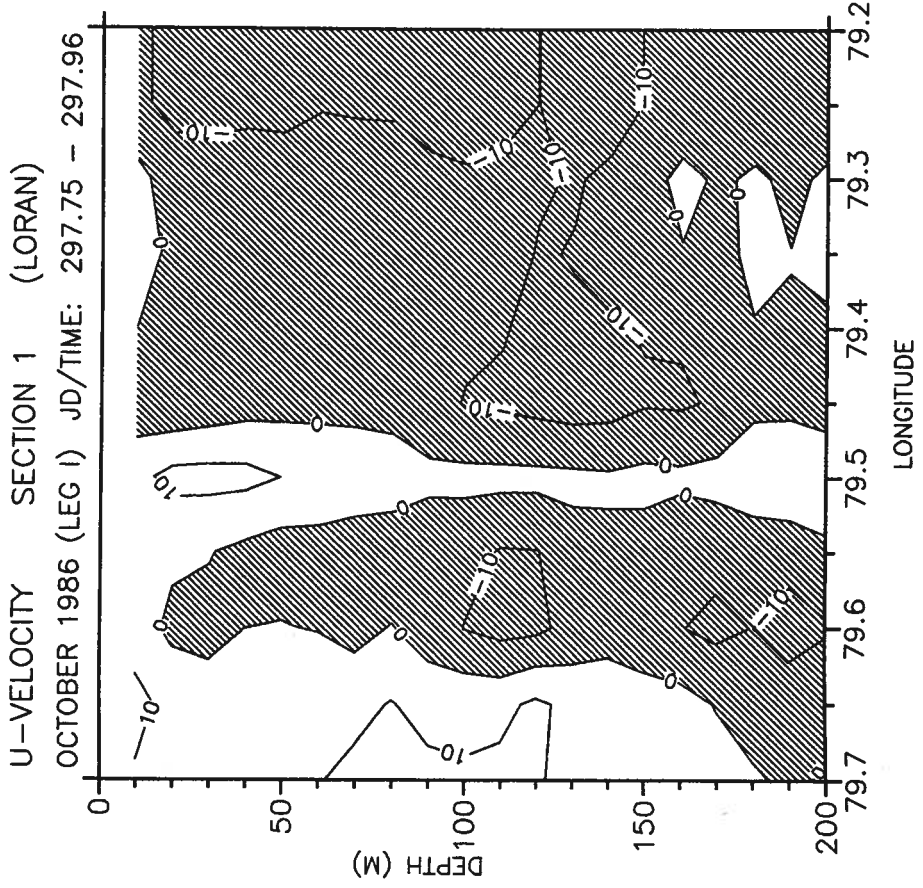
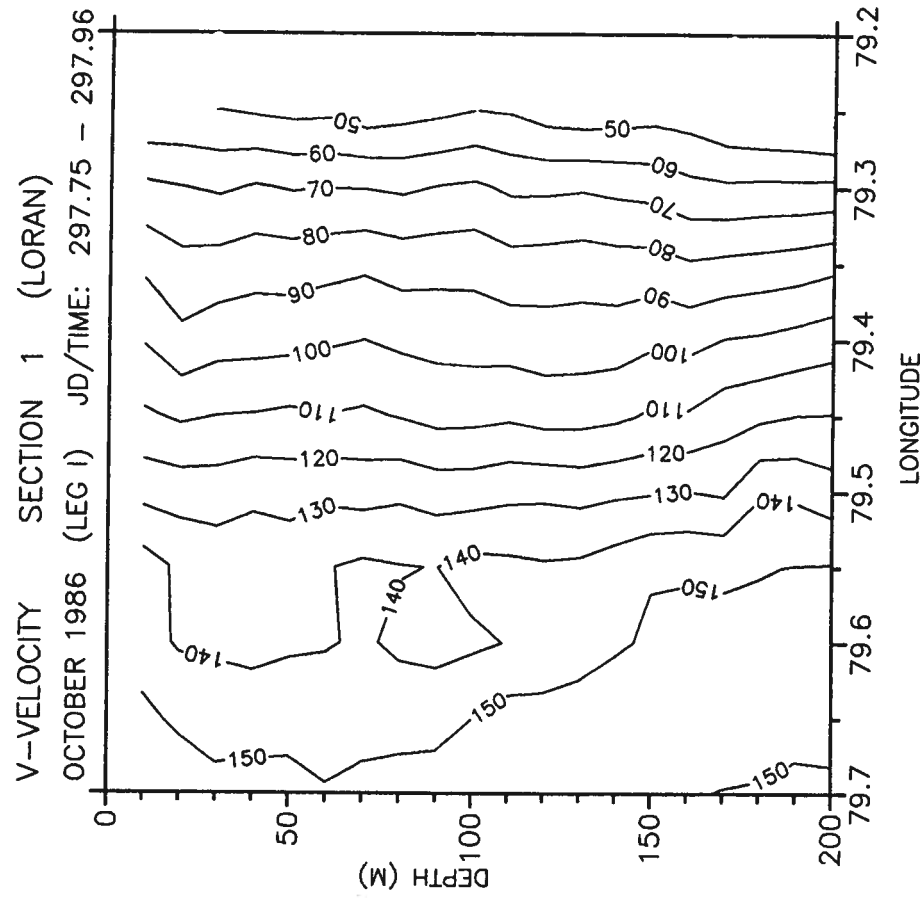

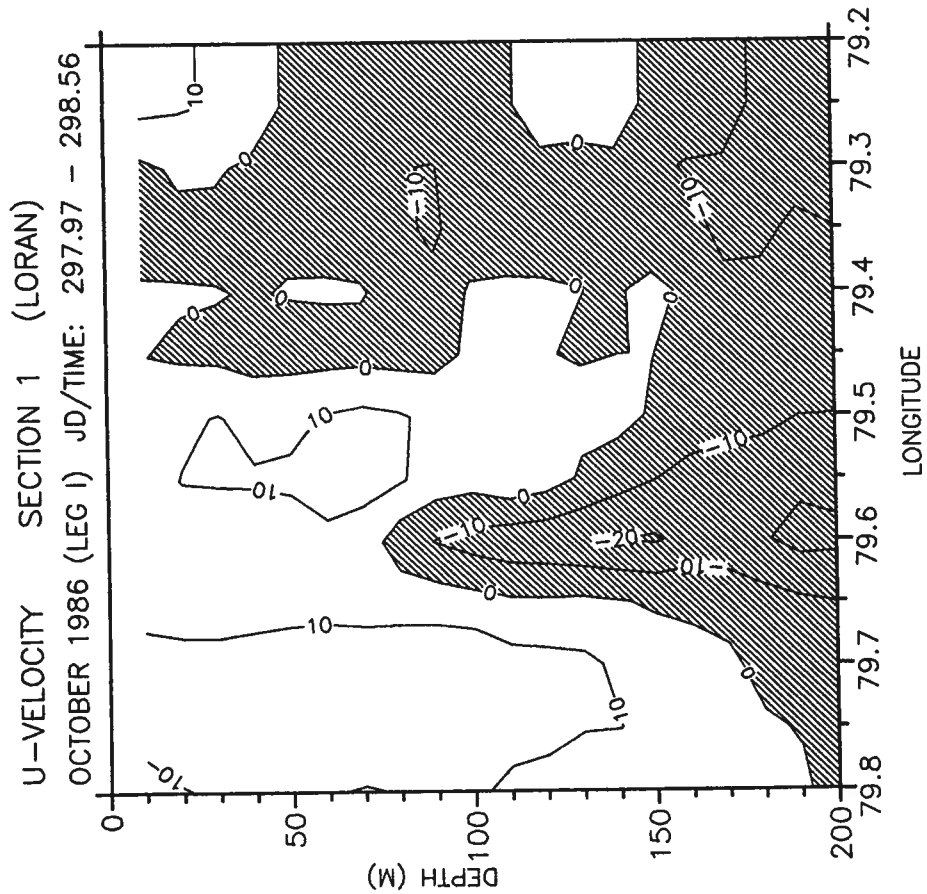
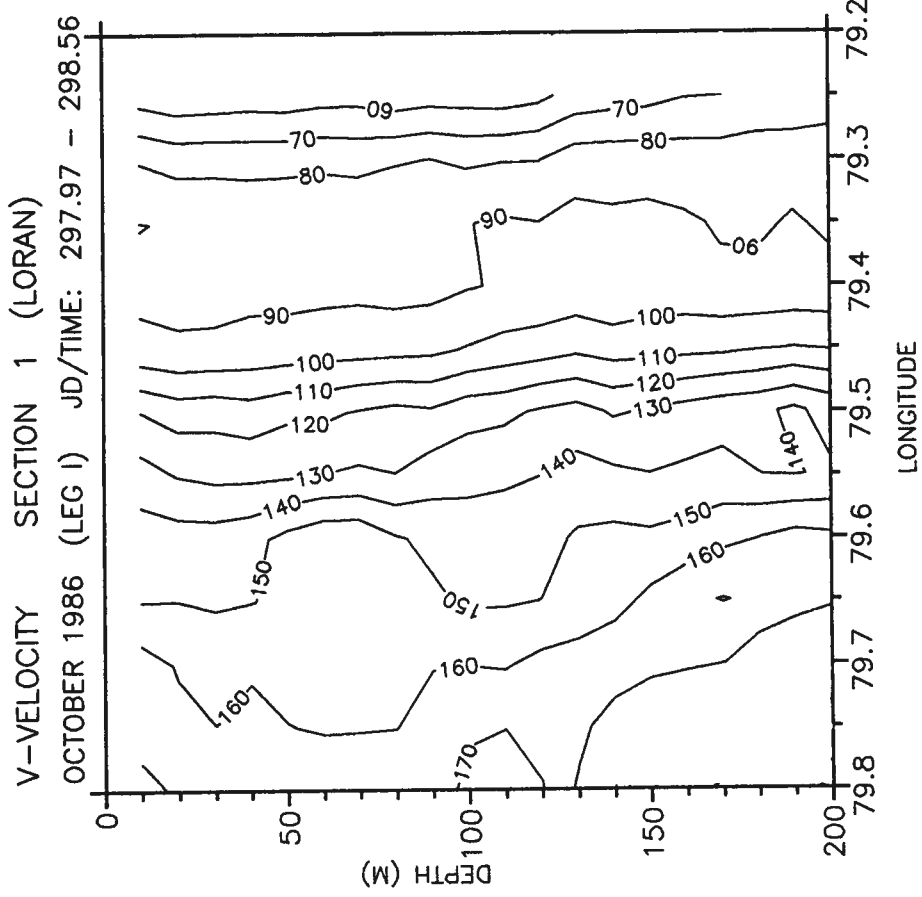

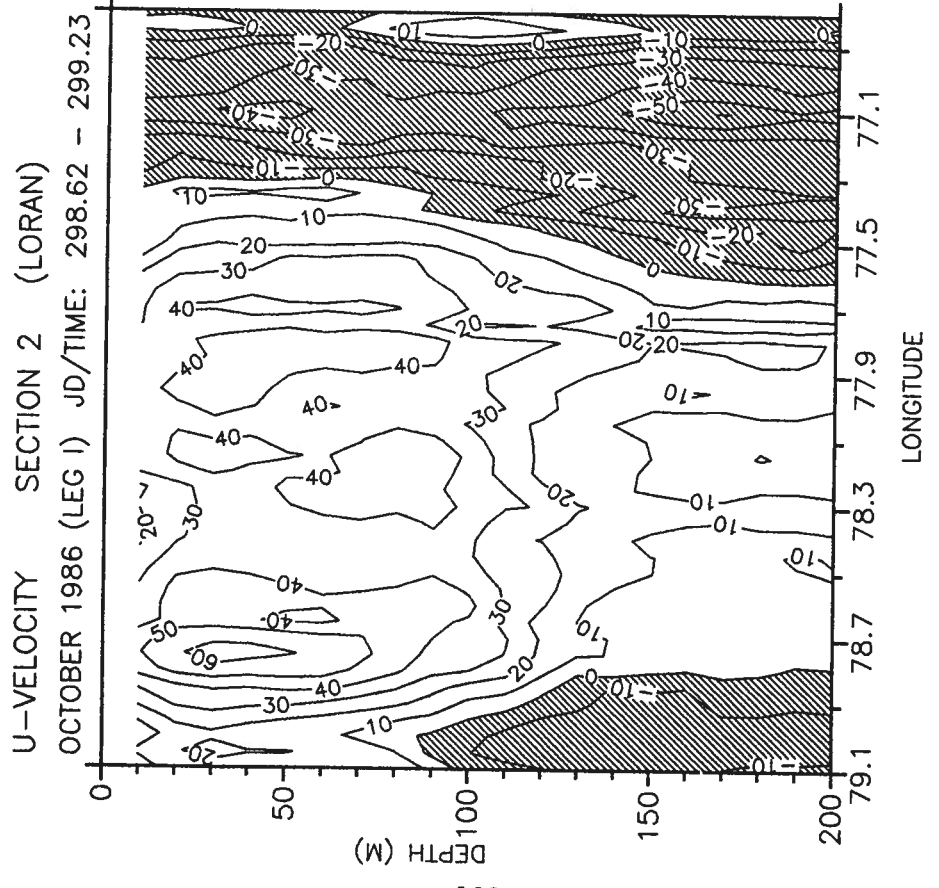
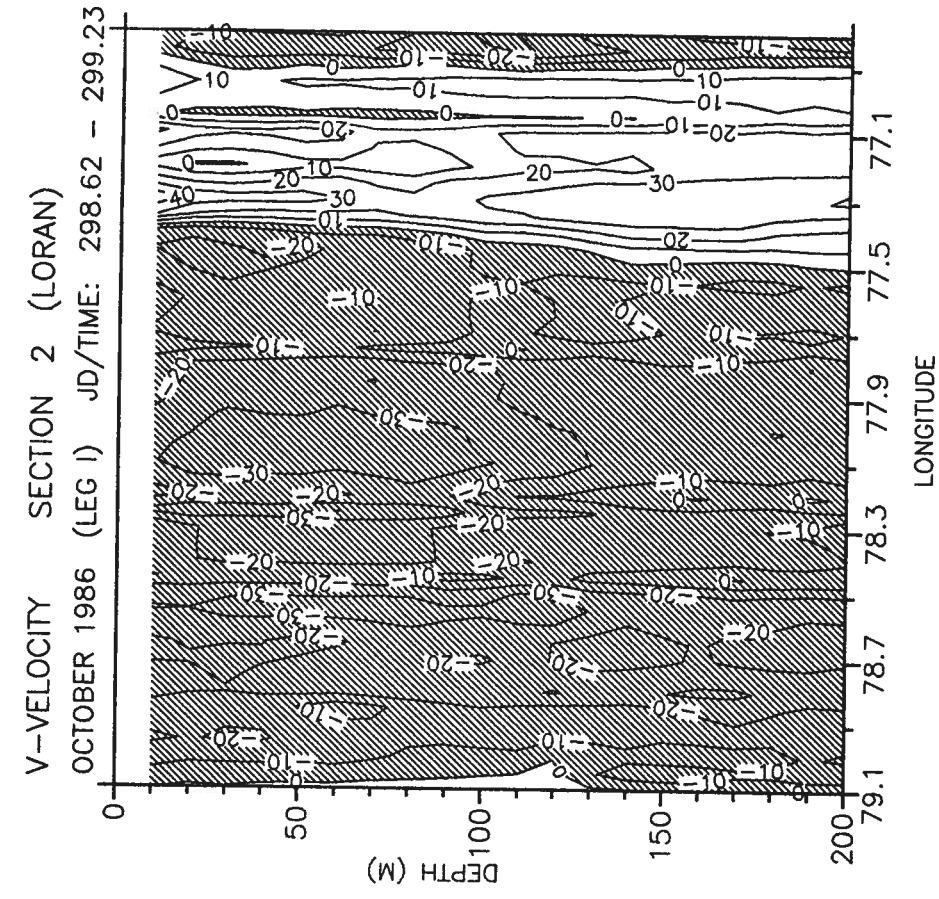

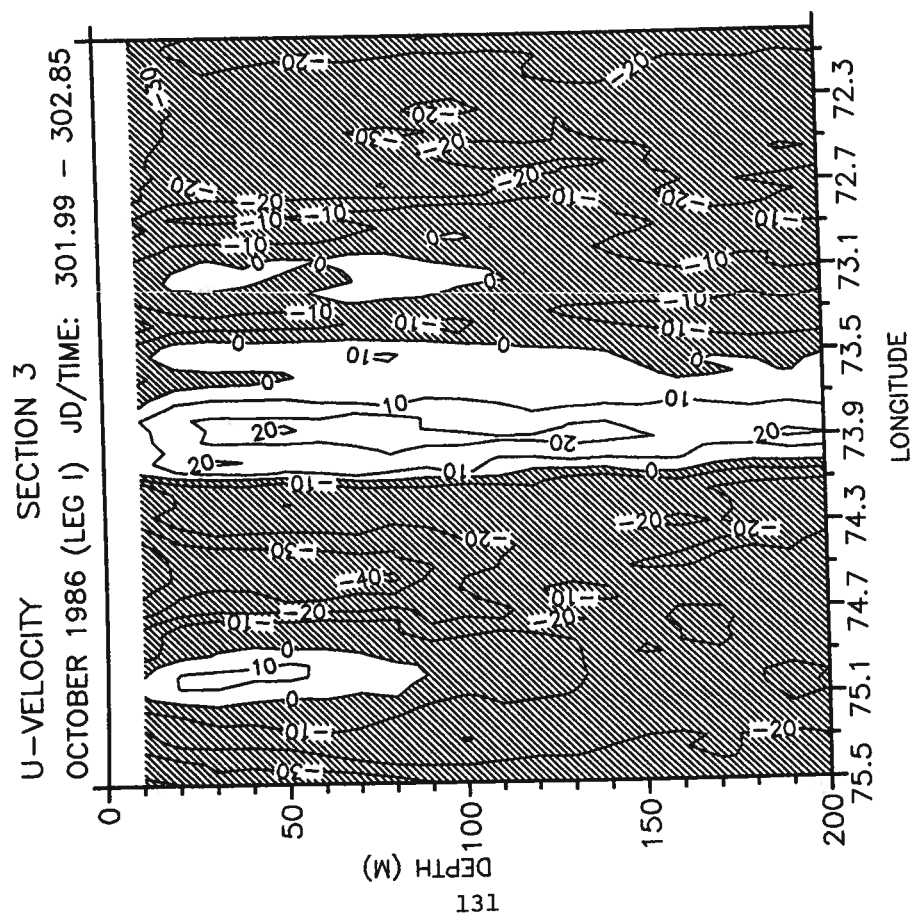
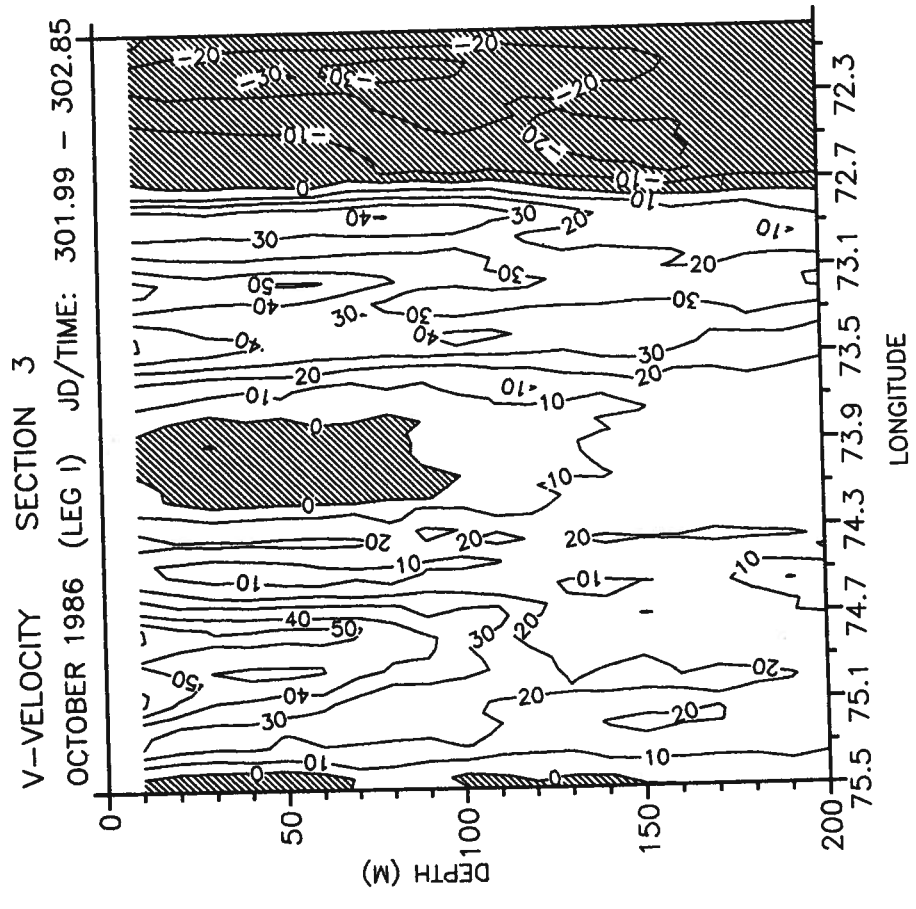



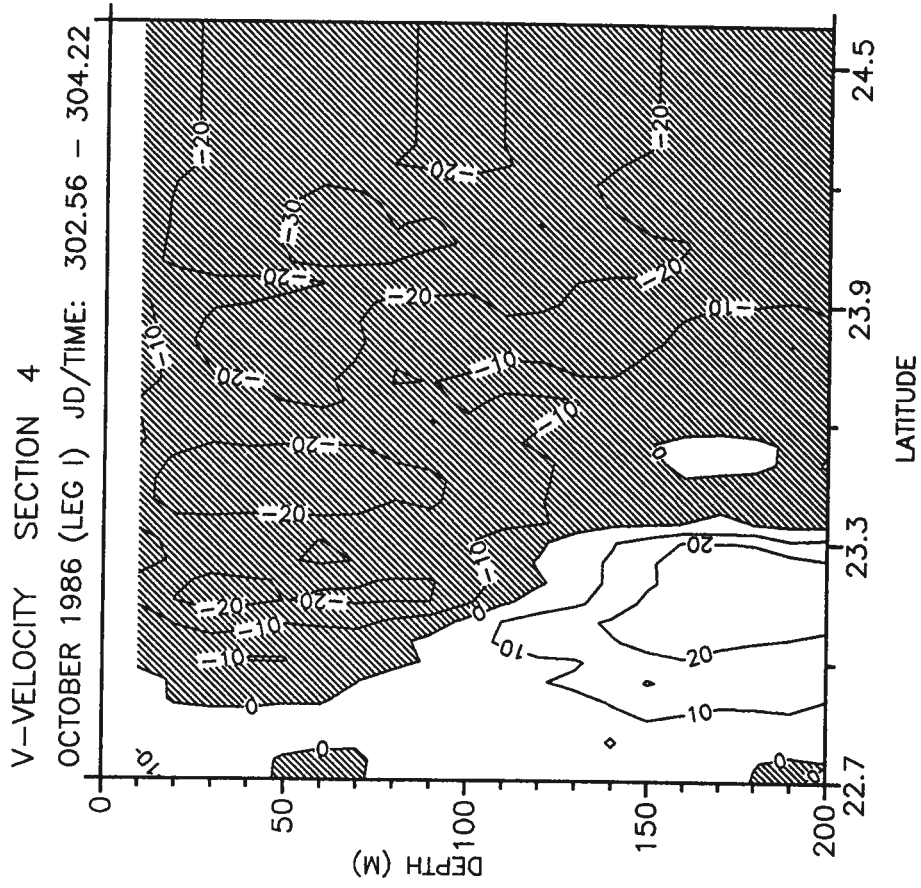
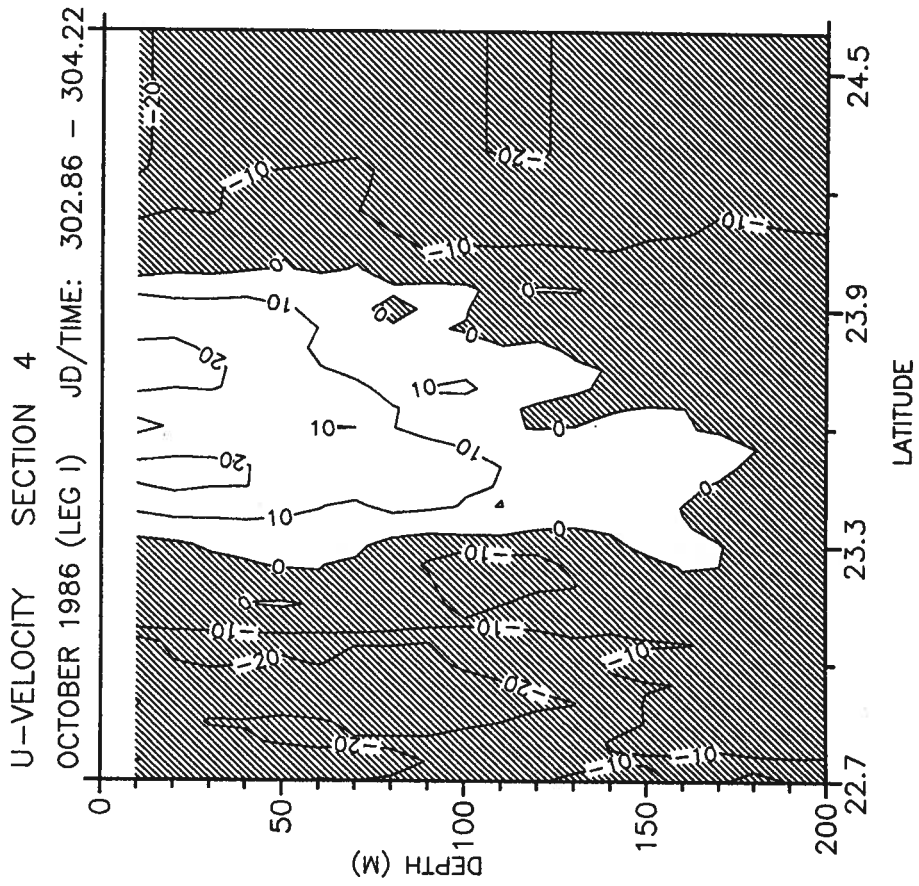

U-VELOCITY SECTION 5

OCTOBER 1986 (LEG 1) JD/TIME: 304.23 - 305.67

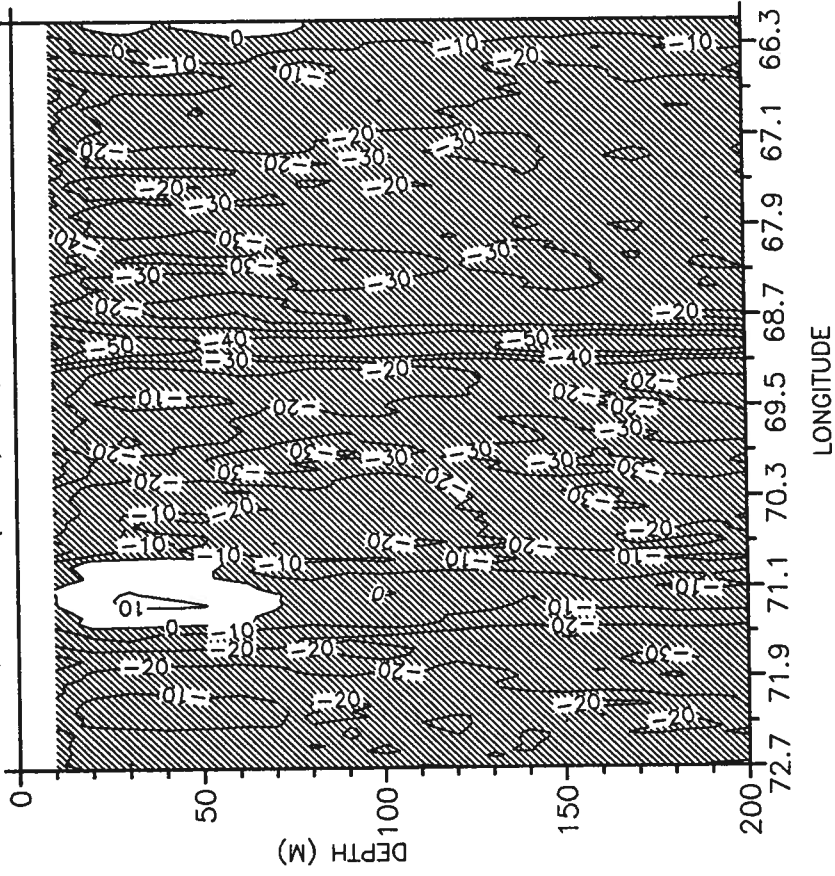

V-VELOCITY SECTION 5

OCTOBER 1986 (LEG 1) JD/TIME: 304.23 - 305.67

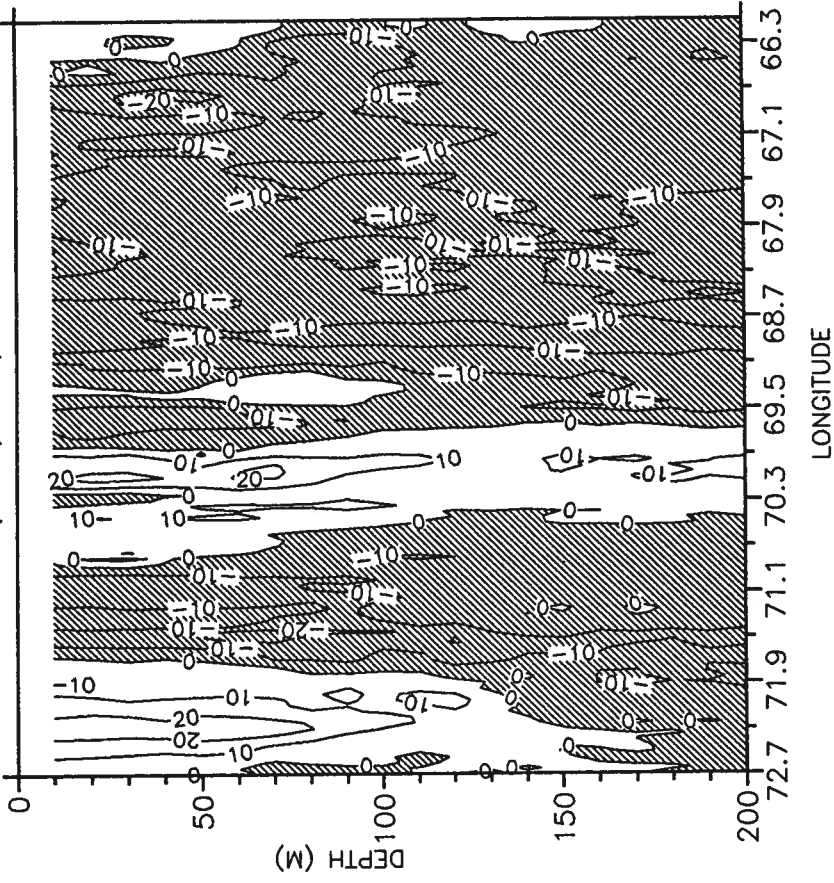

U-VELOCITY SECTION 6

OCTOBER 1986 (LEG I) JD/TIME: 305.69 - 307.33

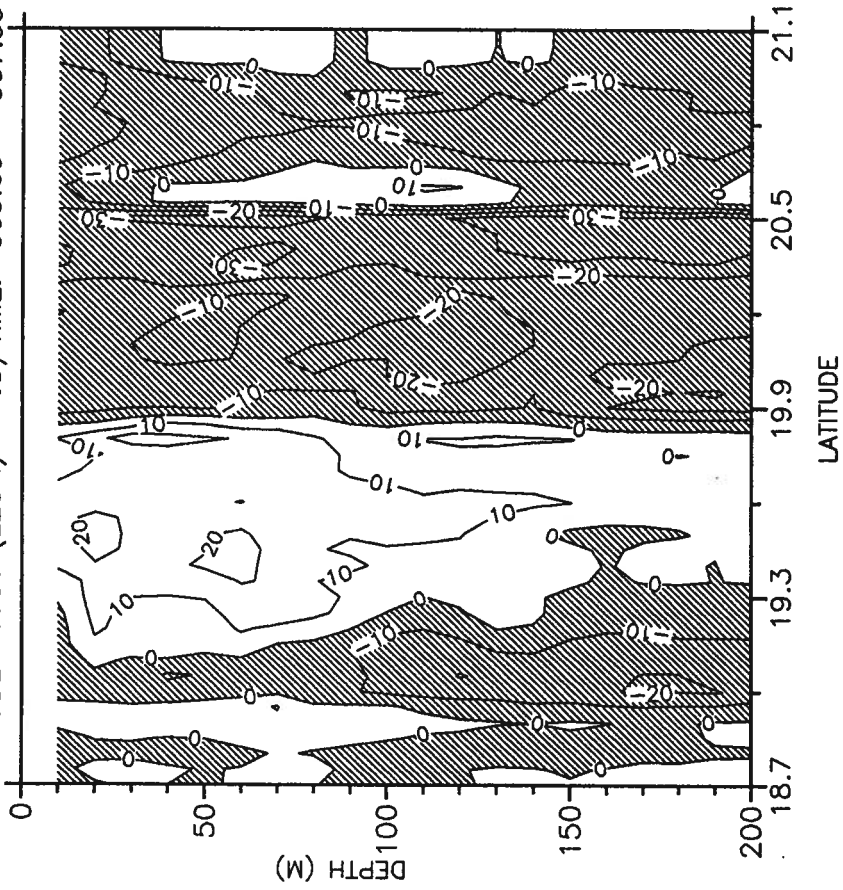

V-VELOCITY SECTION 6

OCTOBER 1986 (LEG I) JD/TIME: 305.69 - 307.33

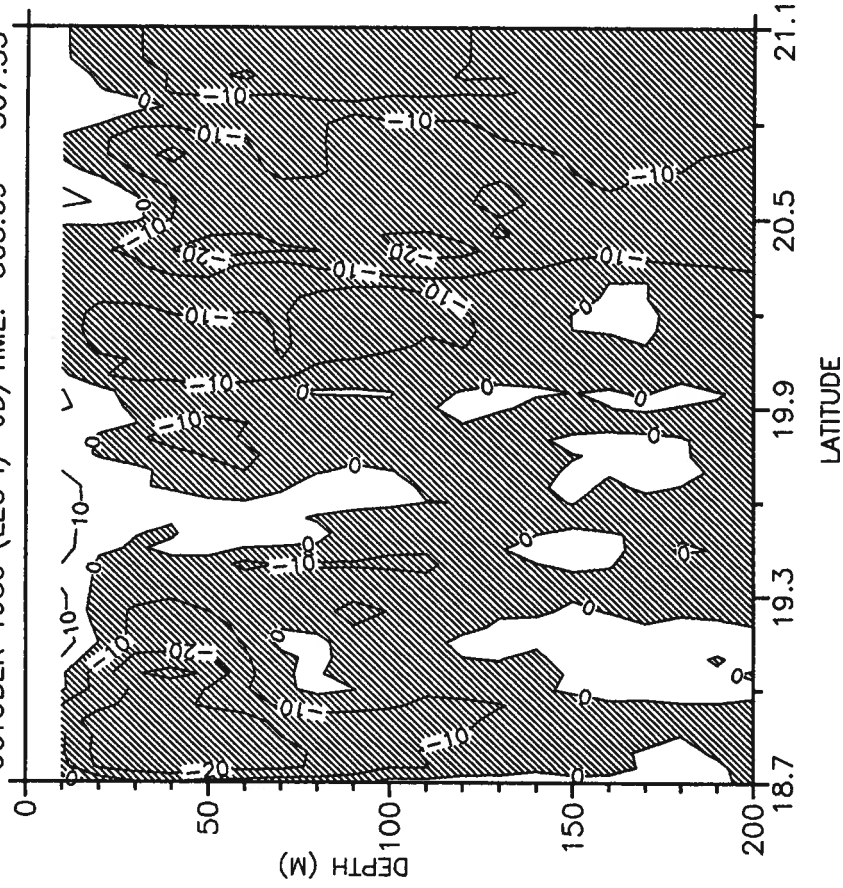

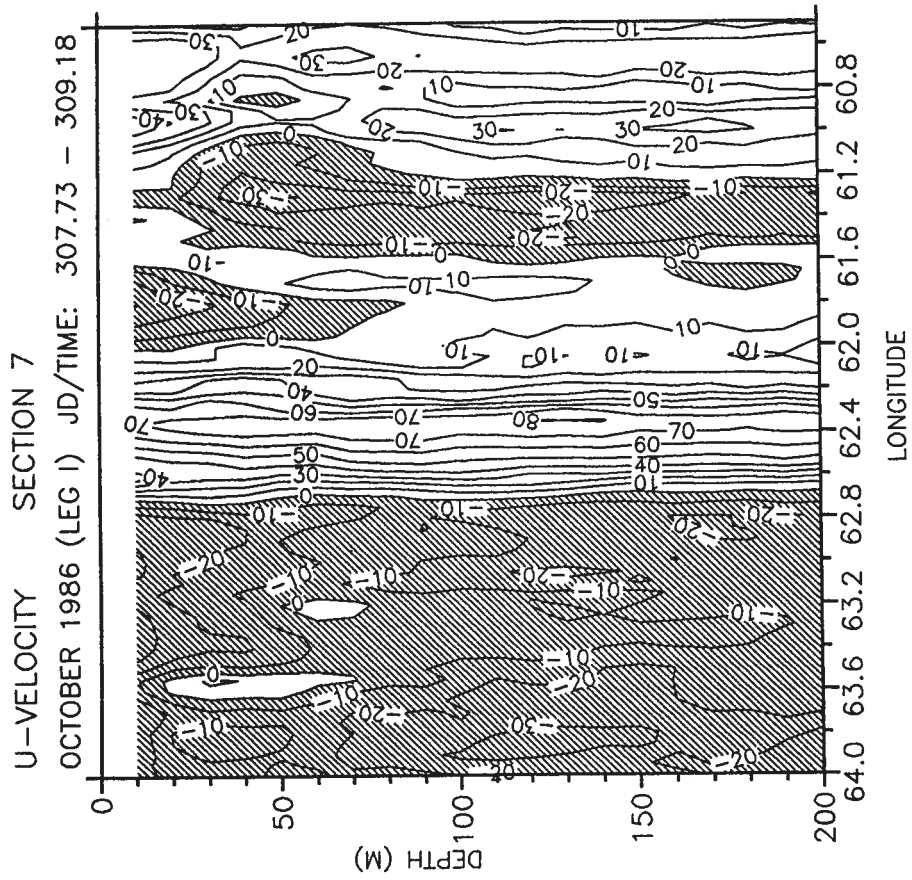
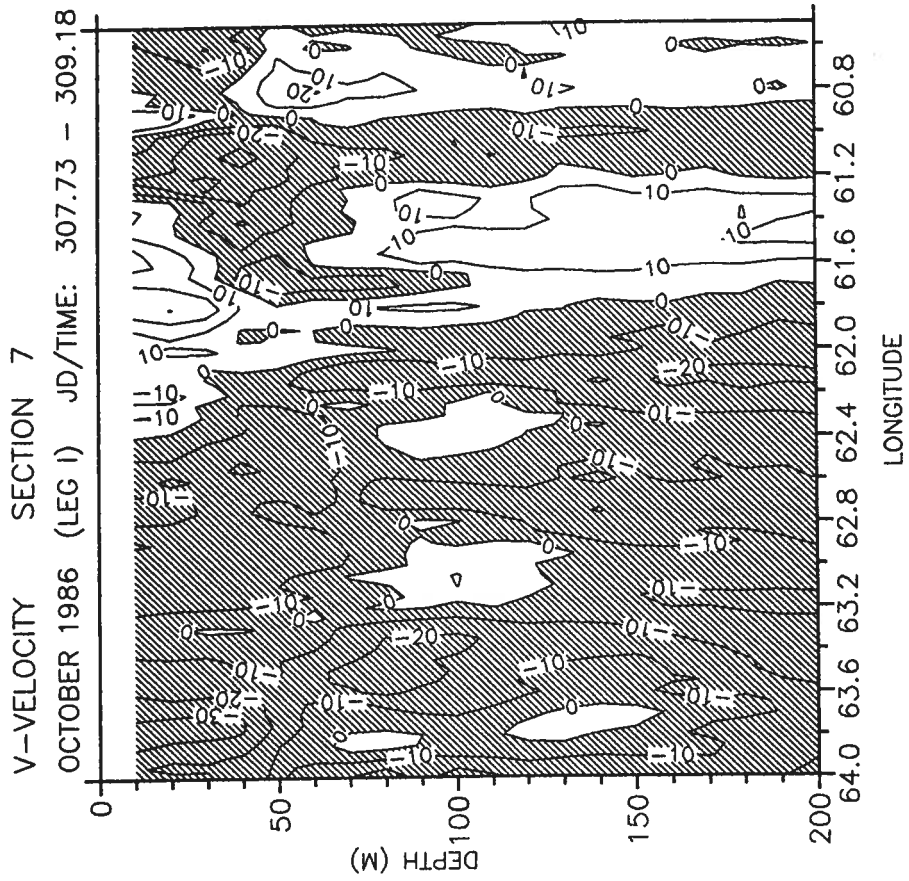

U-VELOCITY SECTION 8

OCTOBER 1986 (LEG I) JD/TIME: 309.20 - 310.49

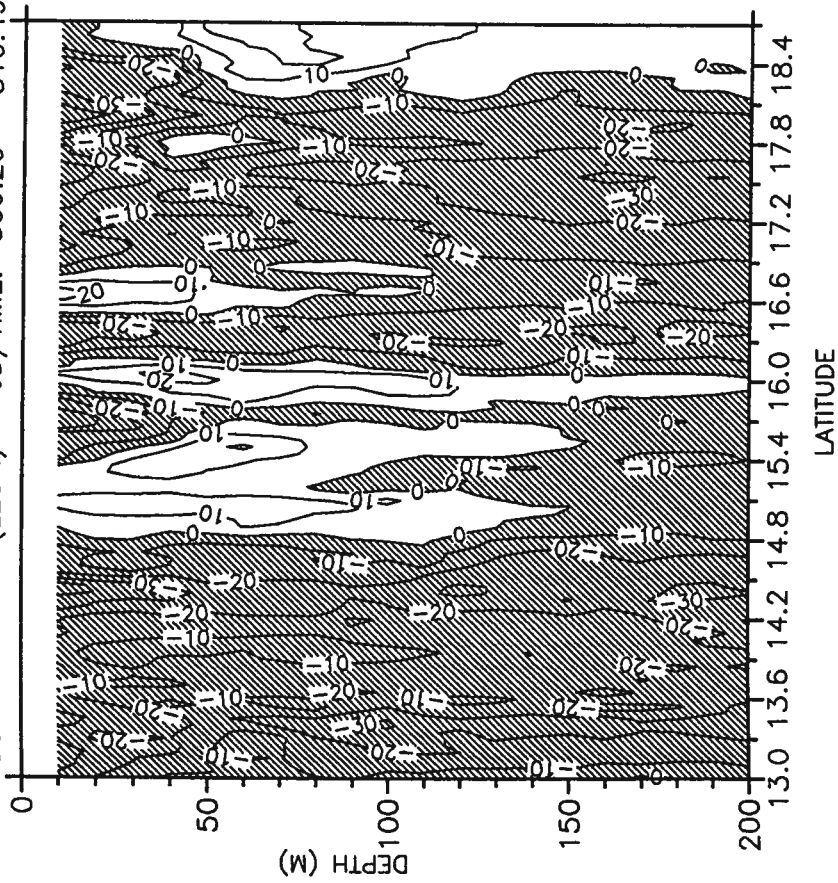

V-VELOCITY SECTION 8

OCTOBER 1986 (LEG I) JD/TIME: 309.20 - 310.49

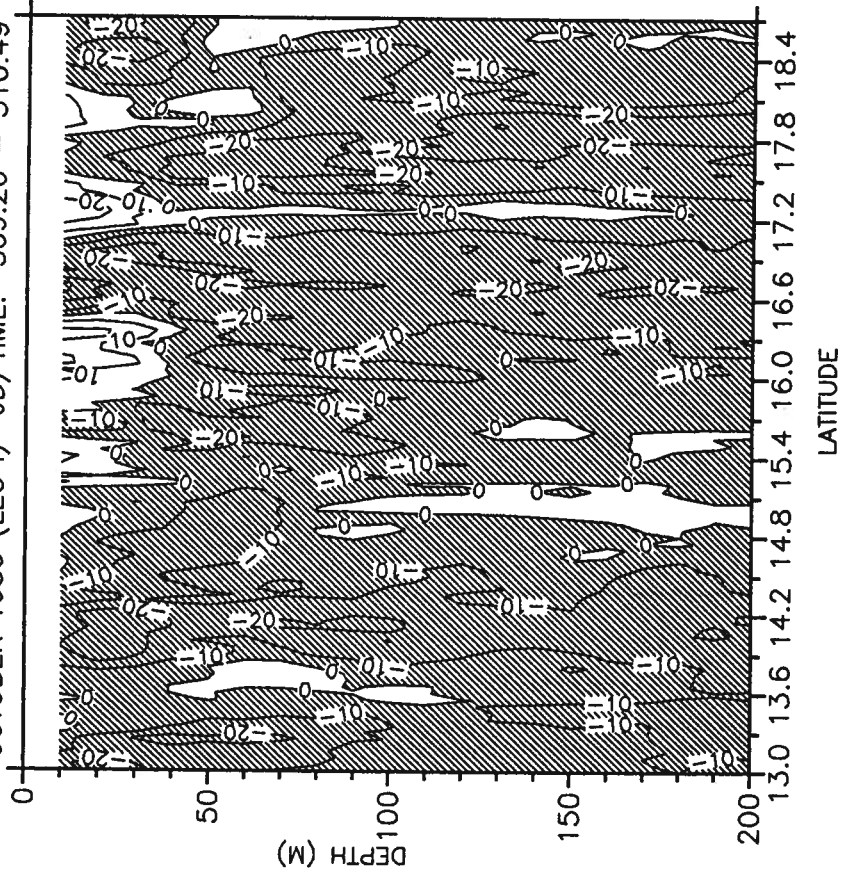

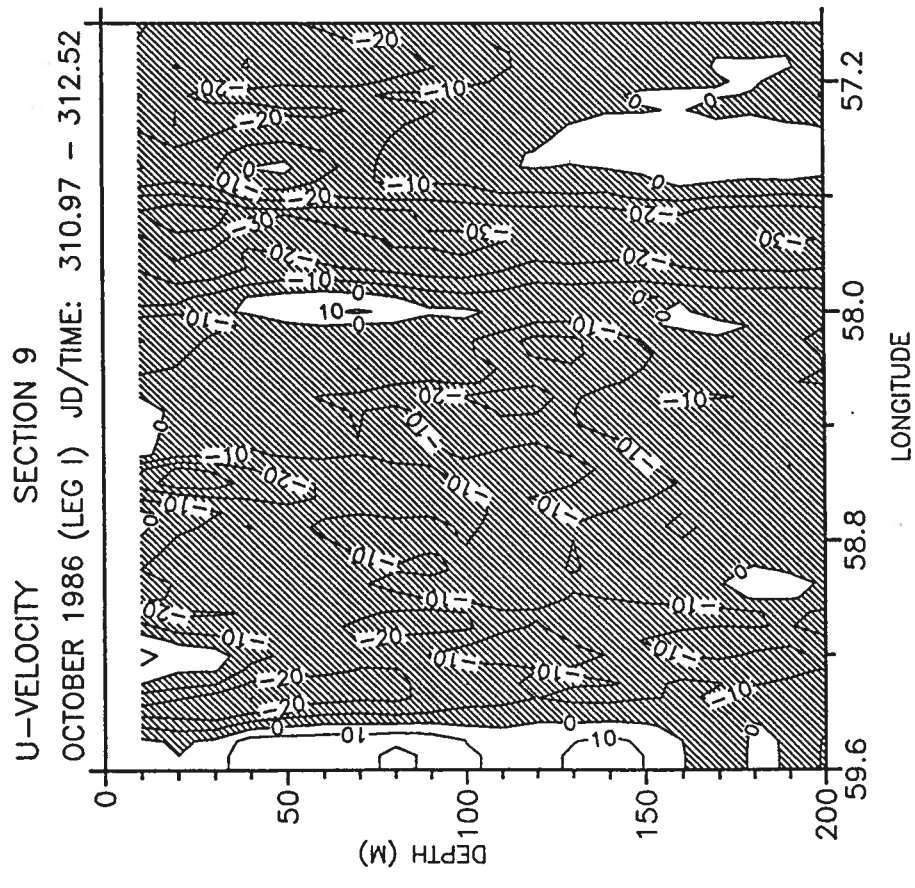
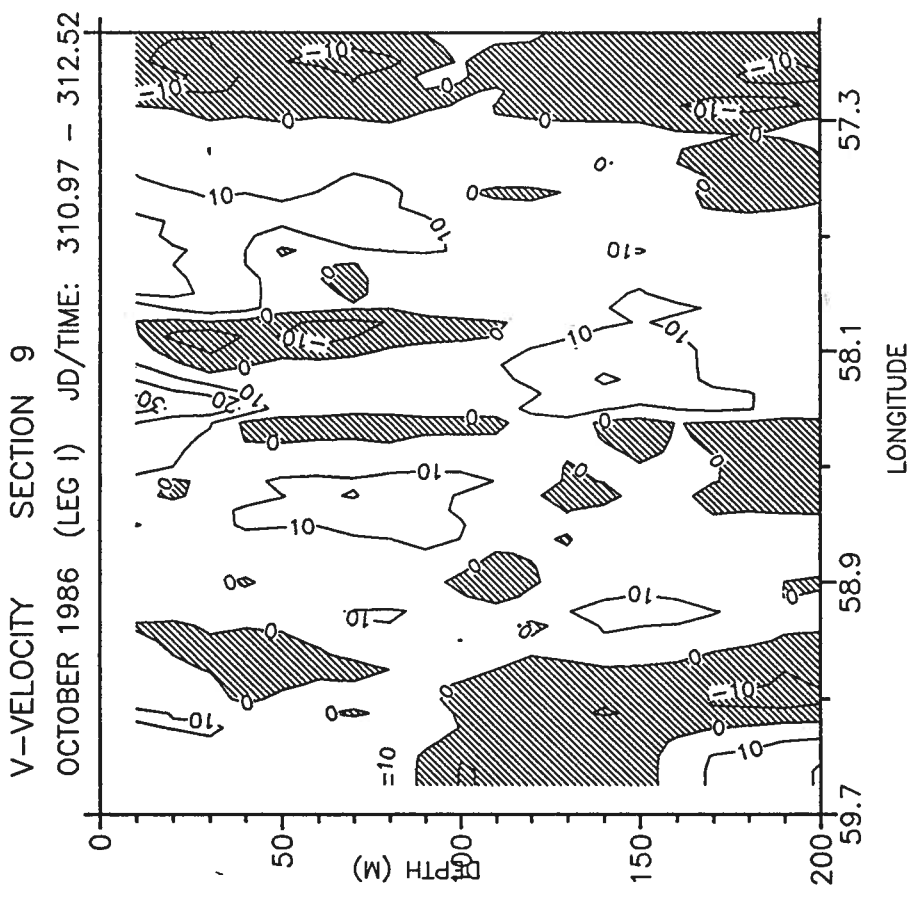

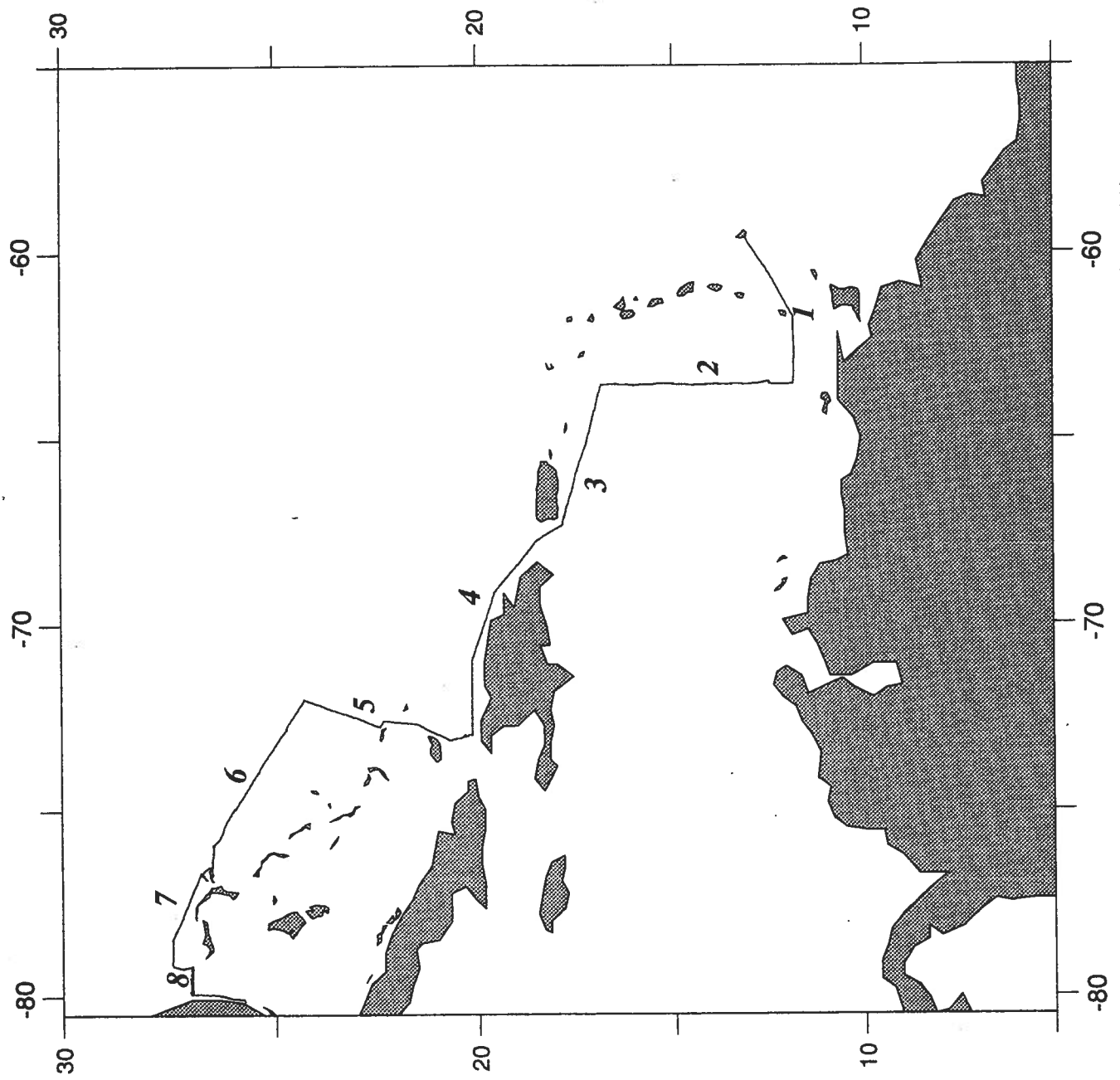

*Map of the Ametek-Straza trackline - October 1986 (Leg II)*



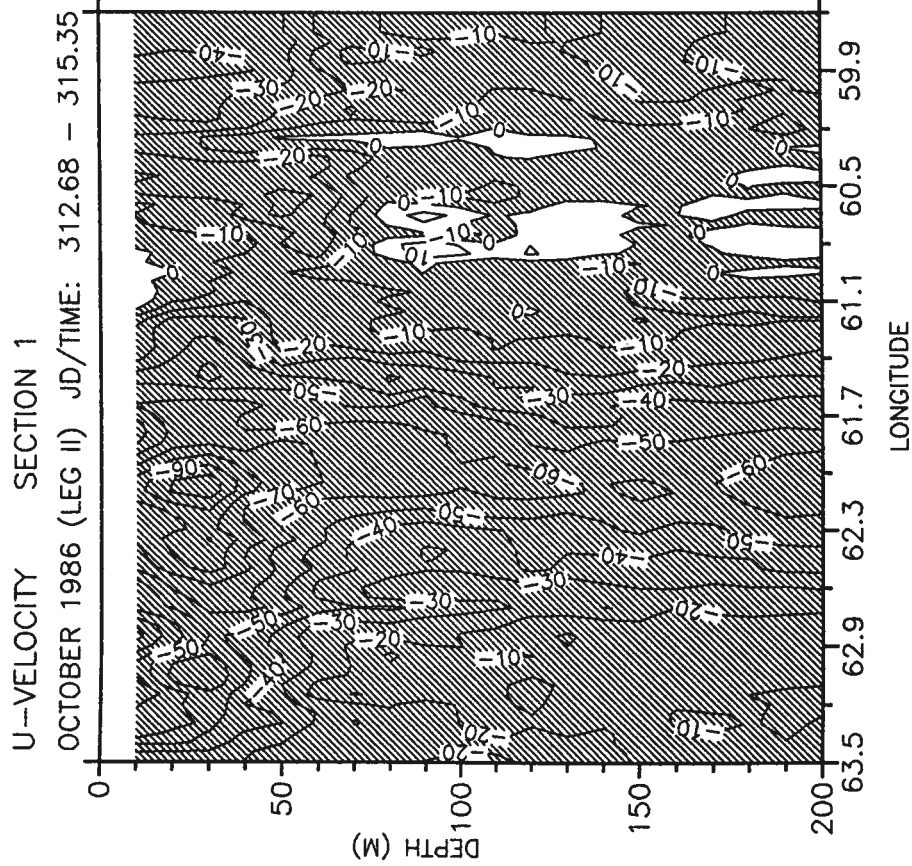
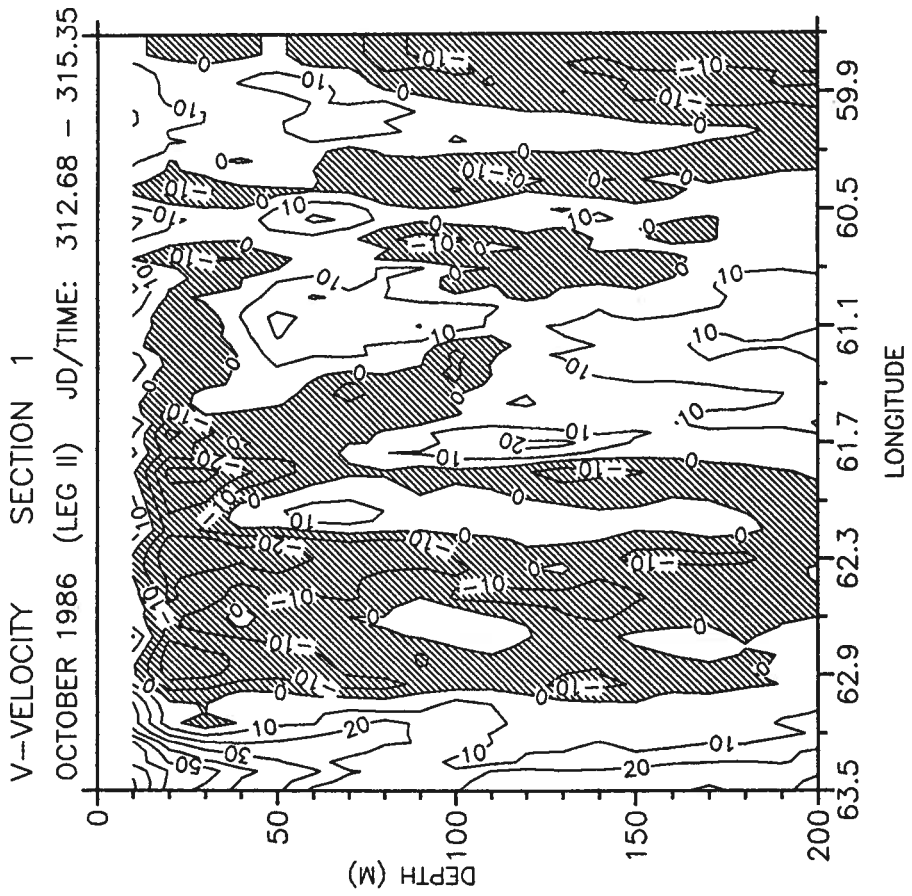



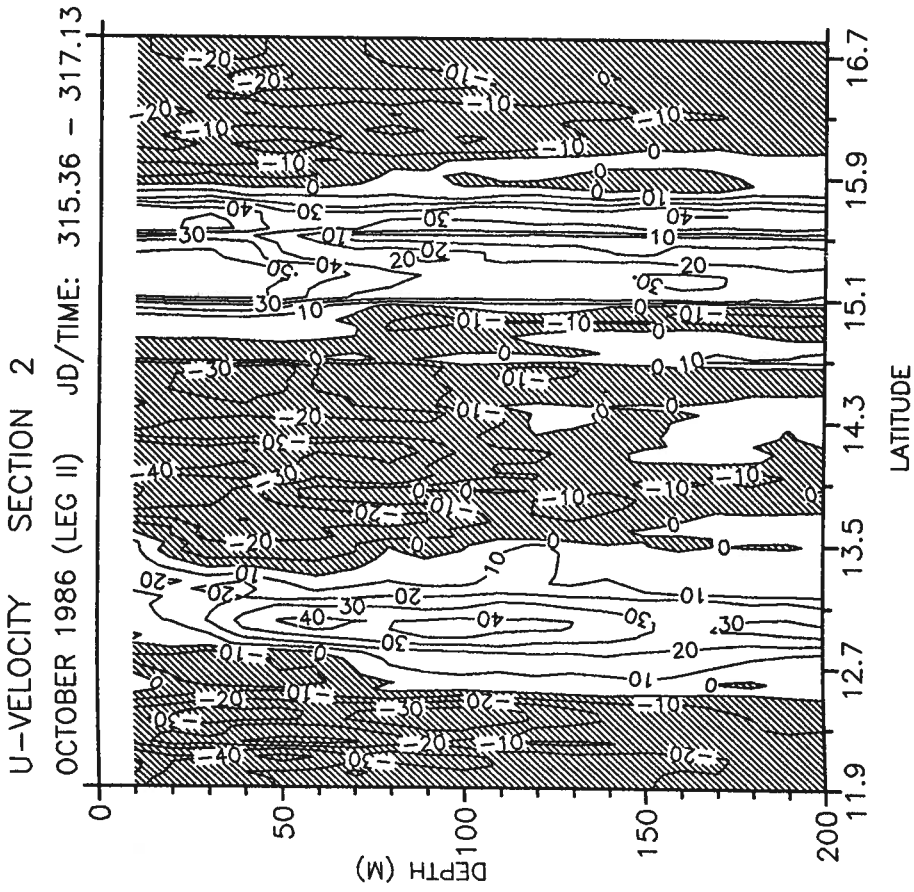
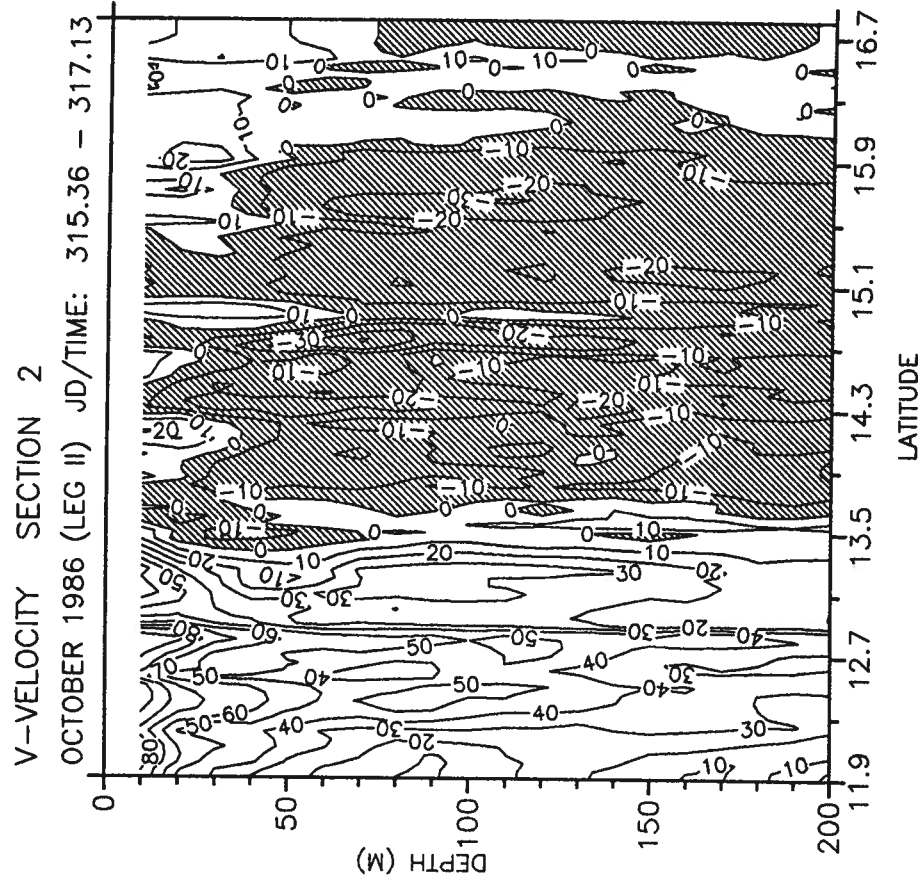

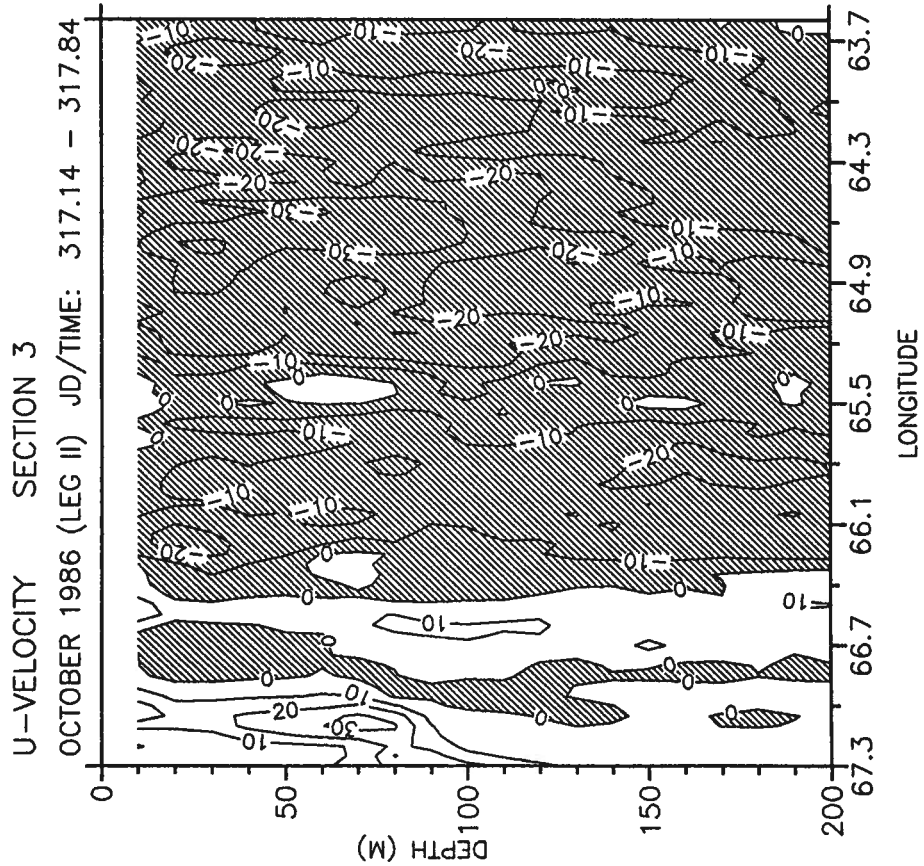
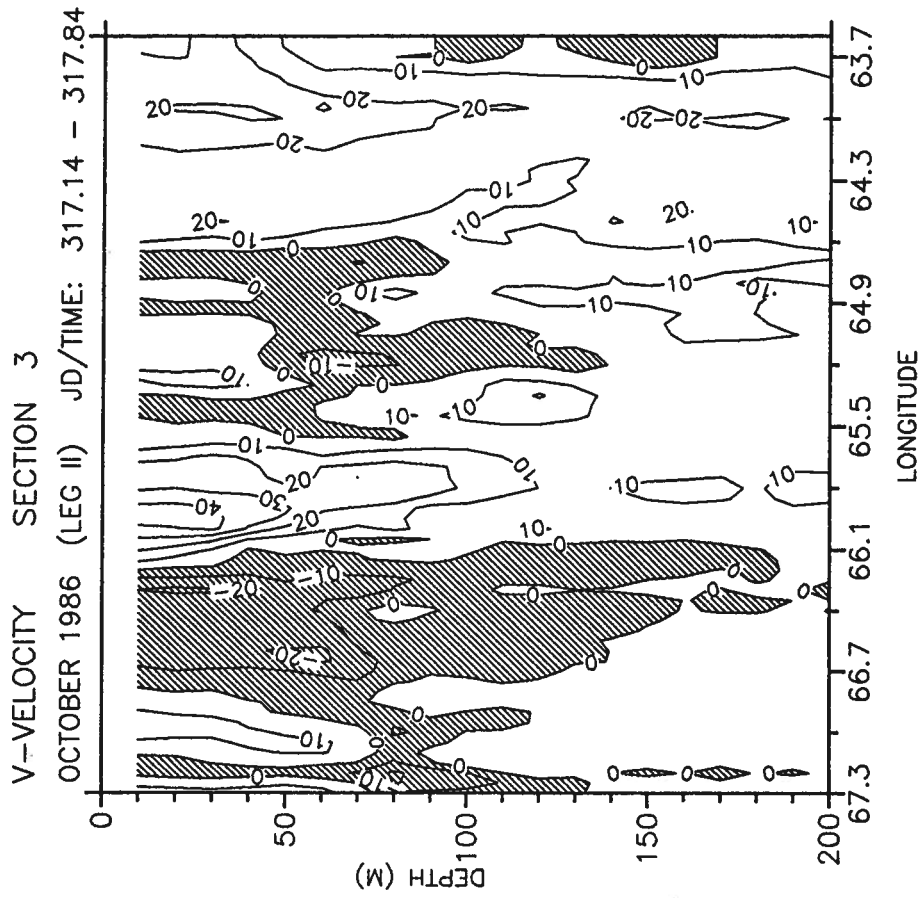

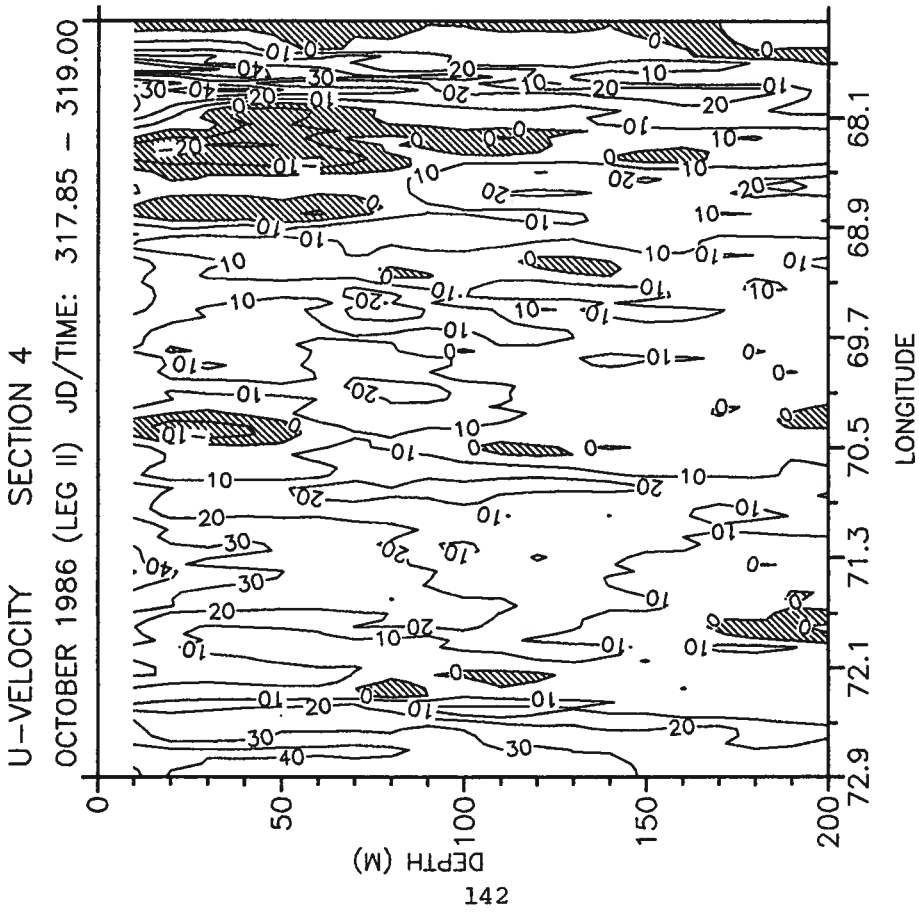
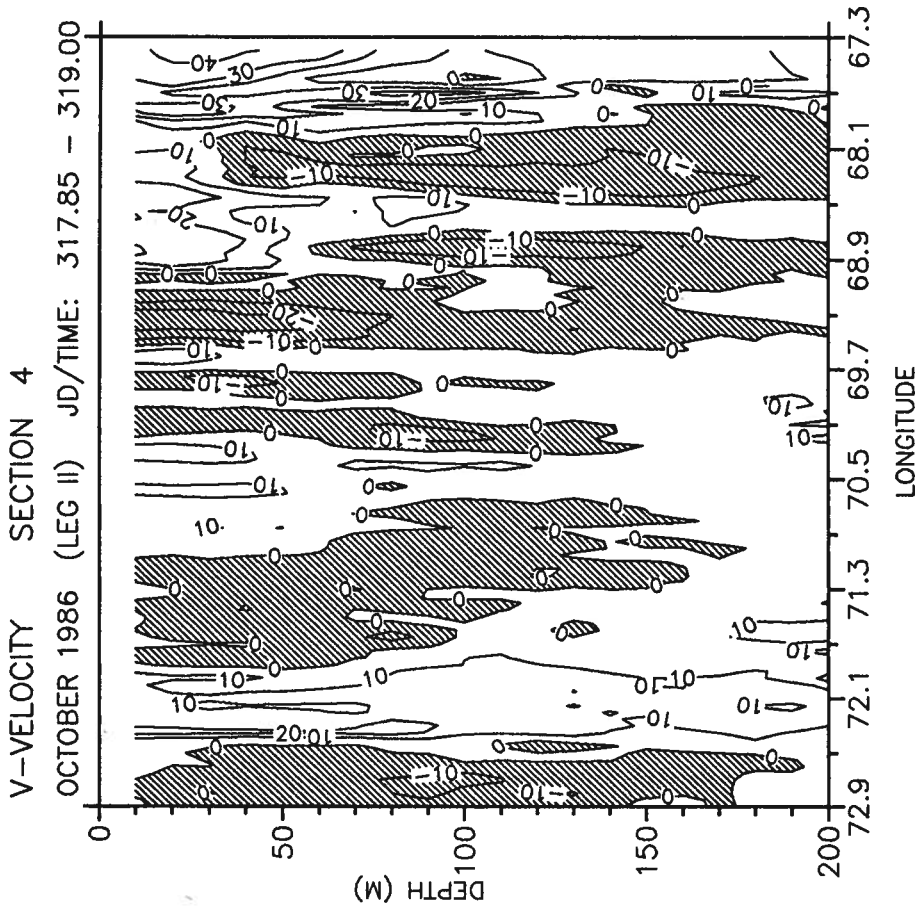

U-VELOCITY SECTION 5

OCTOBER 1986 (LEG II) JD/TIME: 319.01 - 320.70

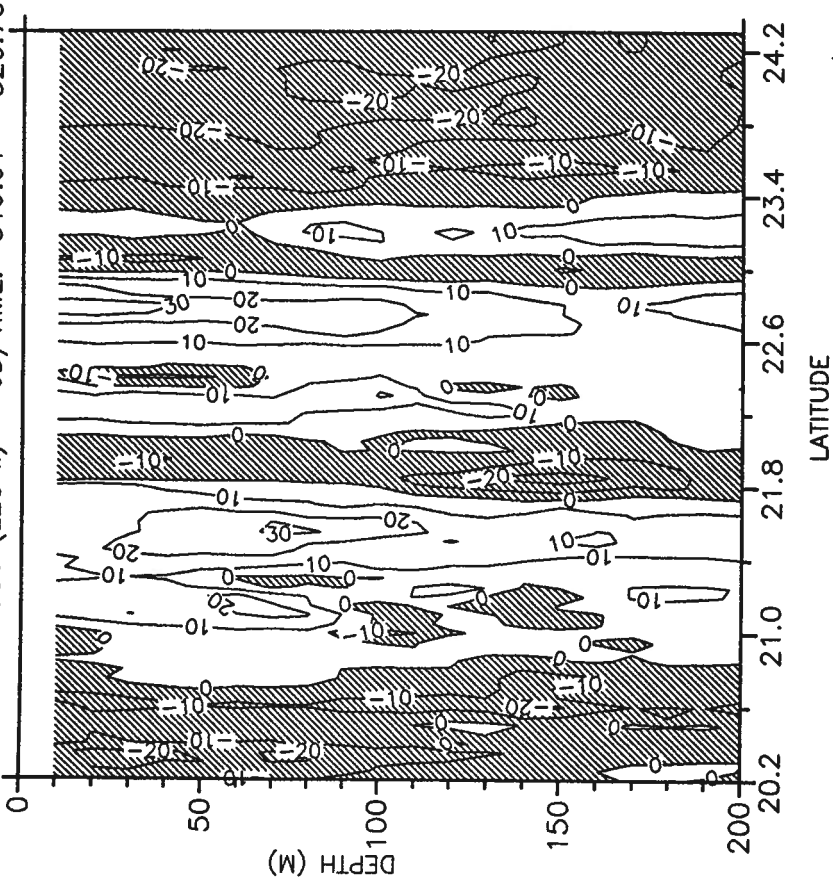

V-VELOCITY SECTION 5

OCTOBER 1986 (LEG II) JD/TIME: 319.01 - 320.70

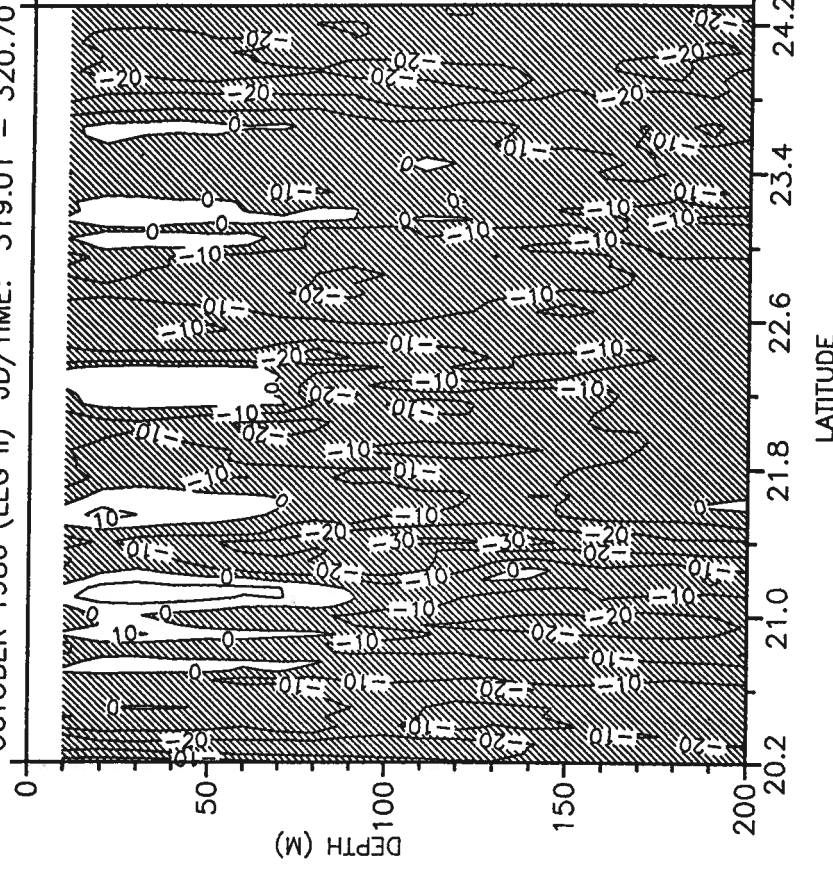

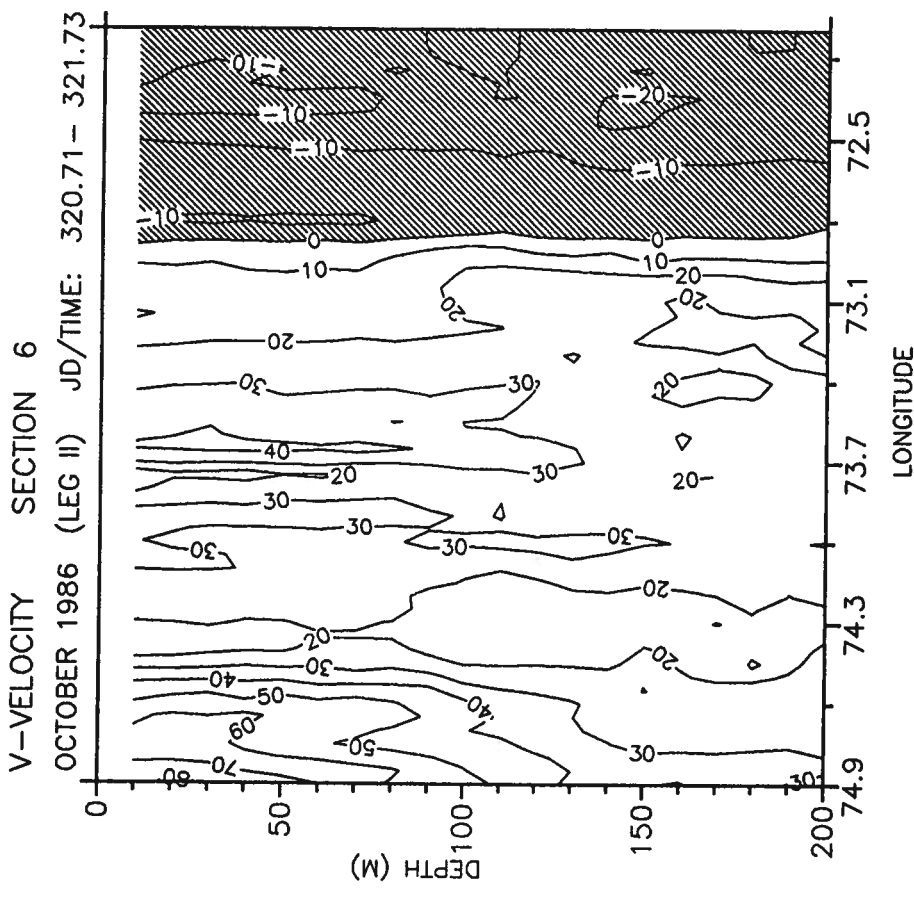
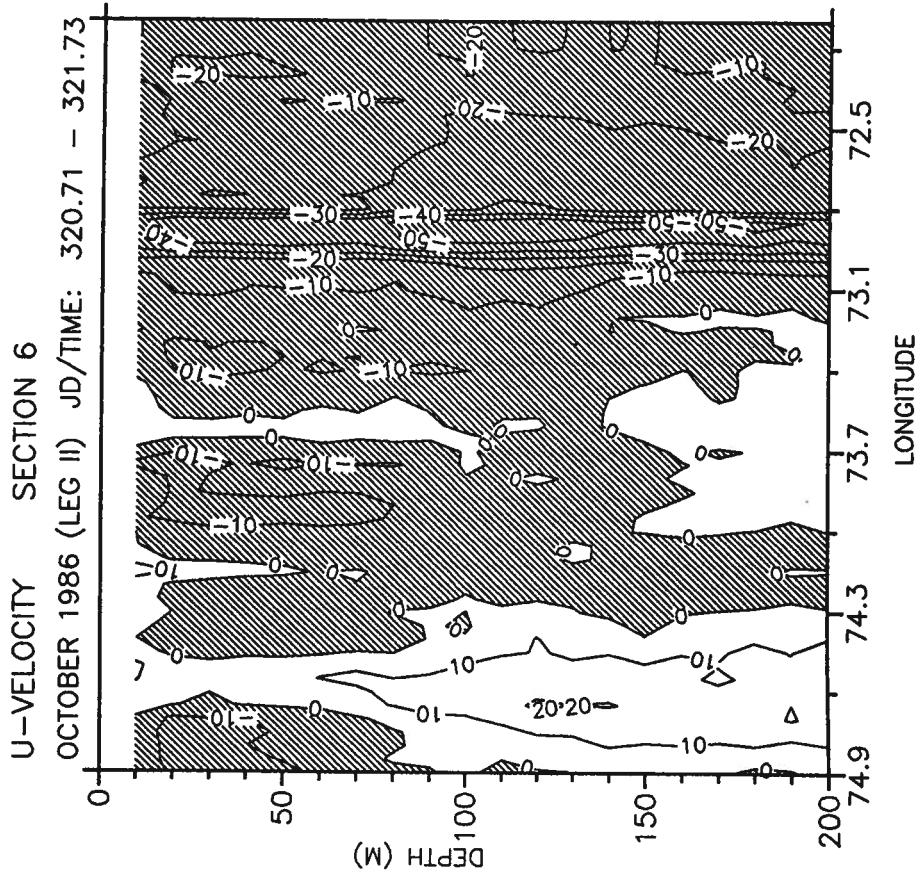

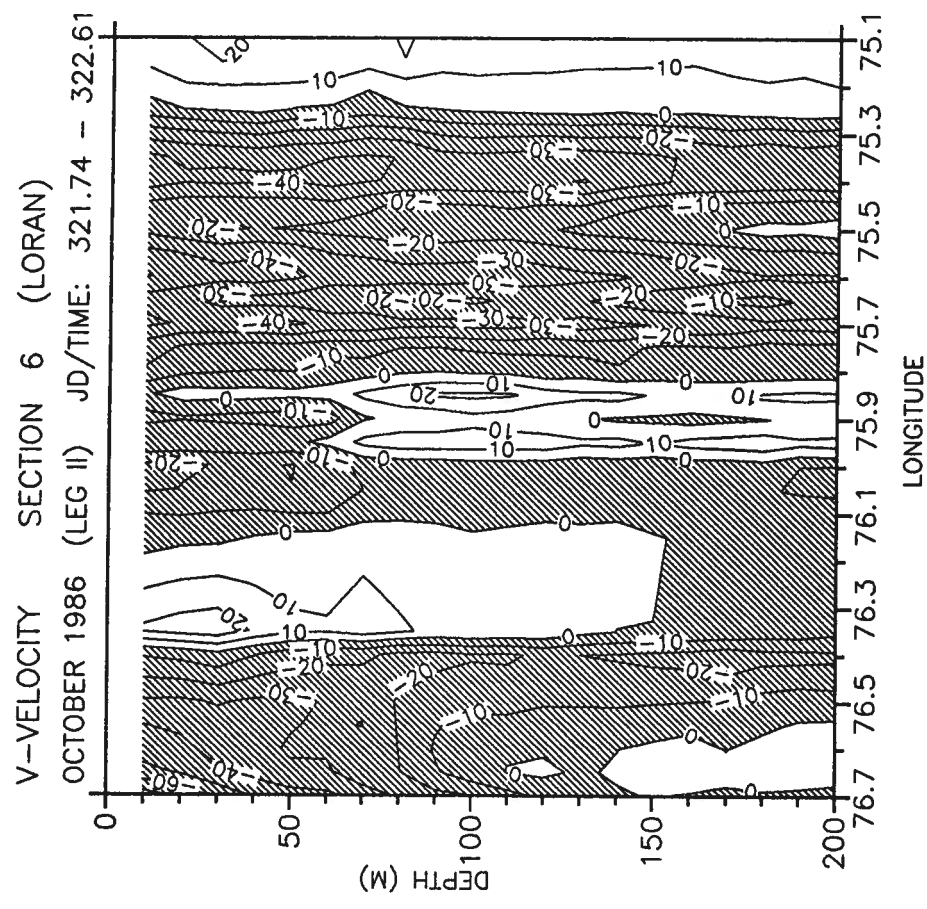
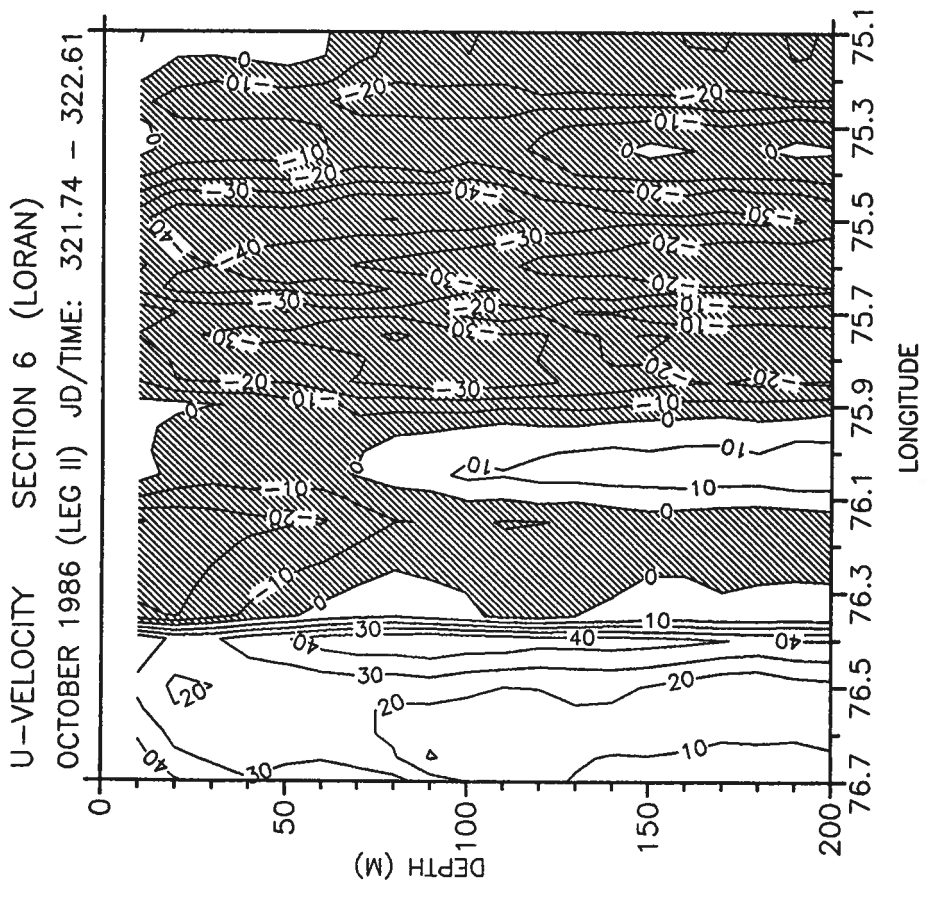

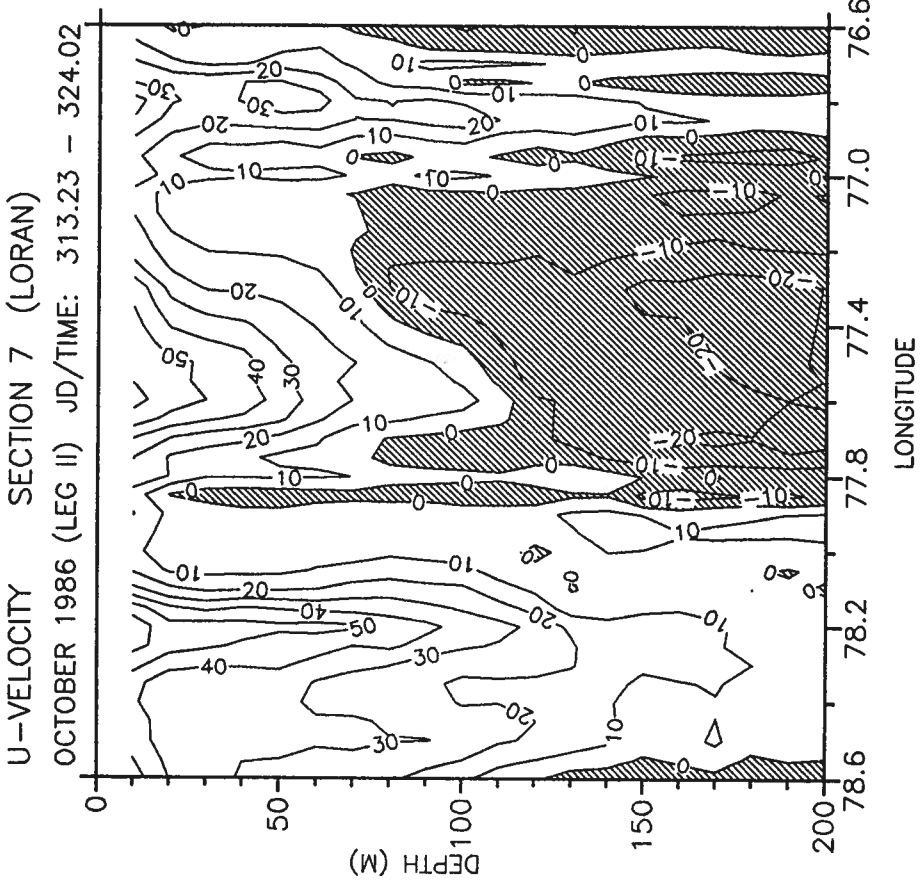
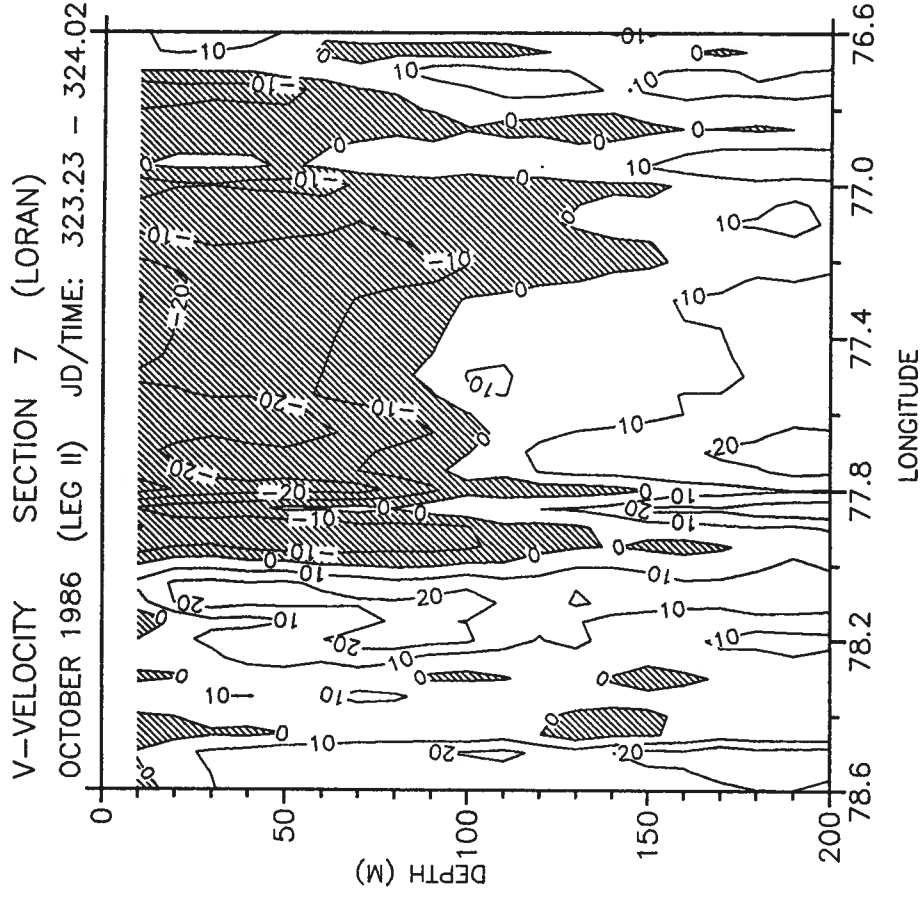

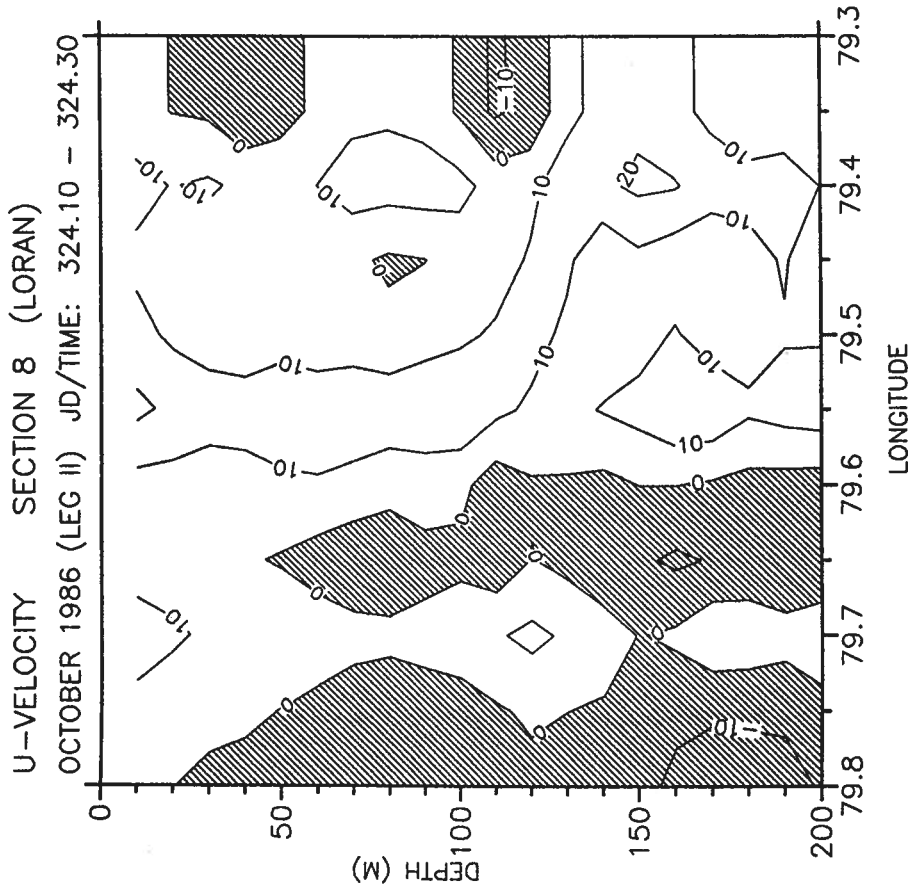
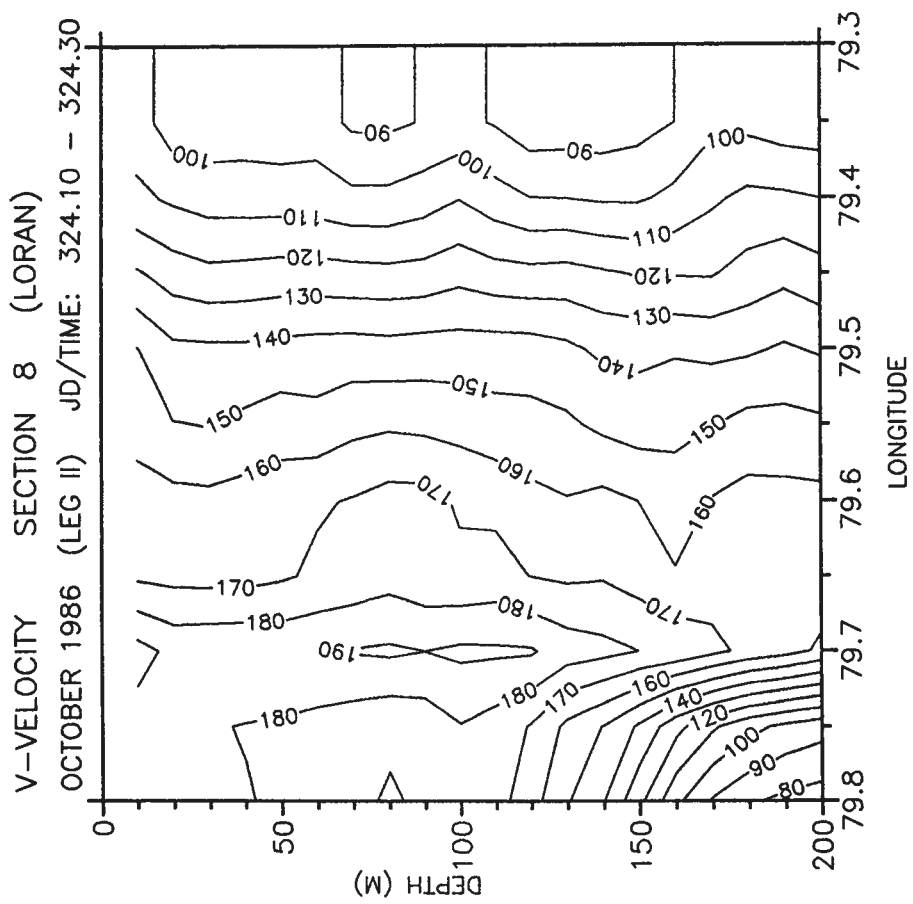



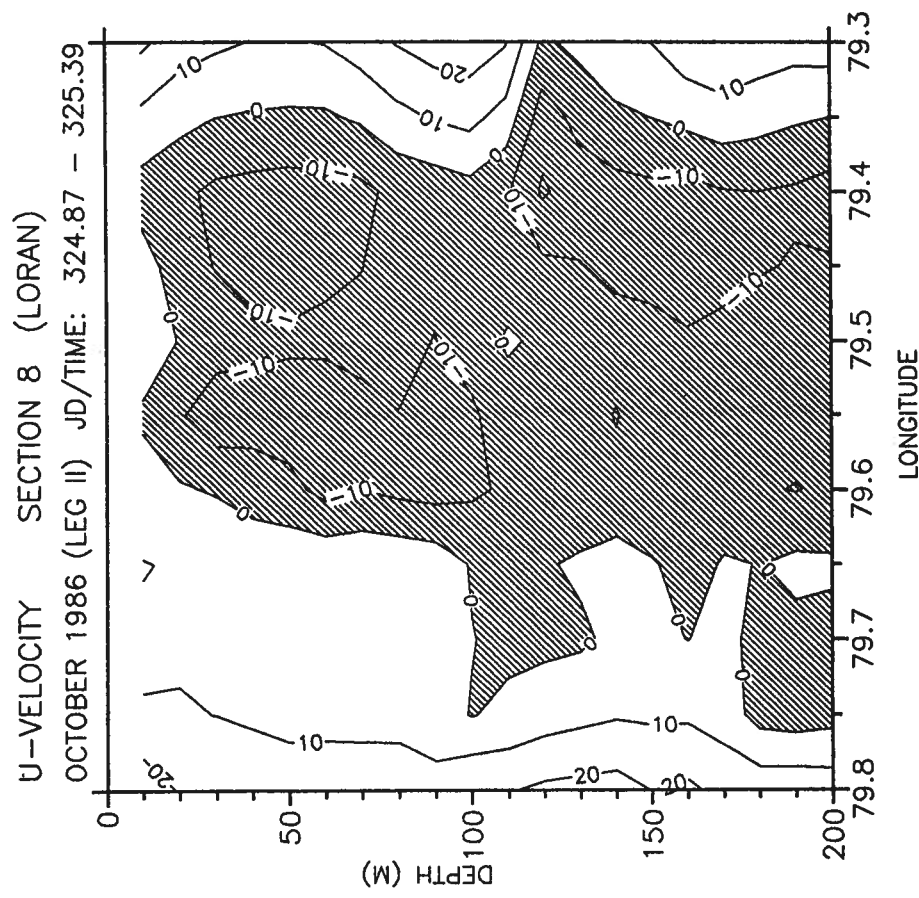
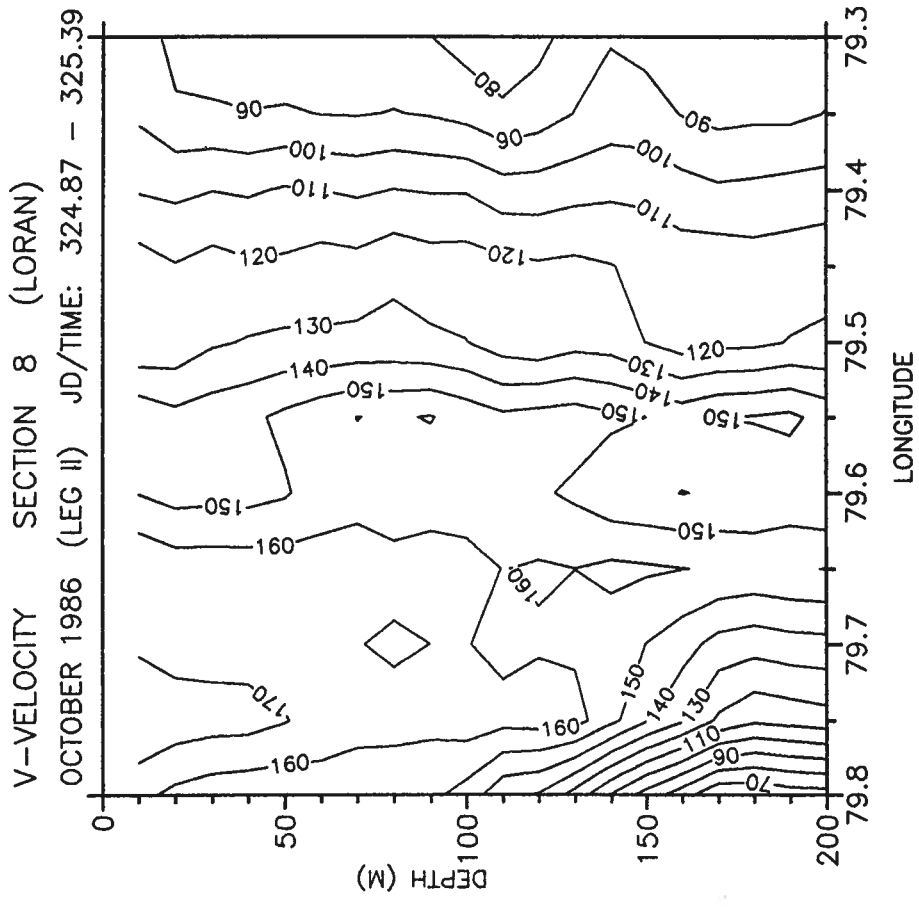

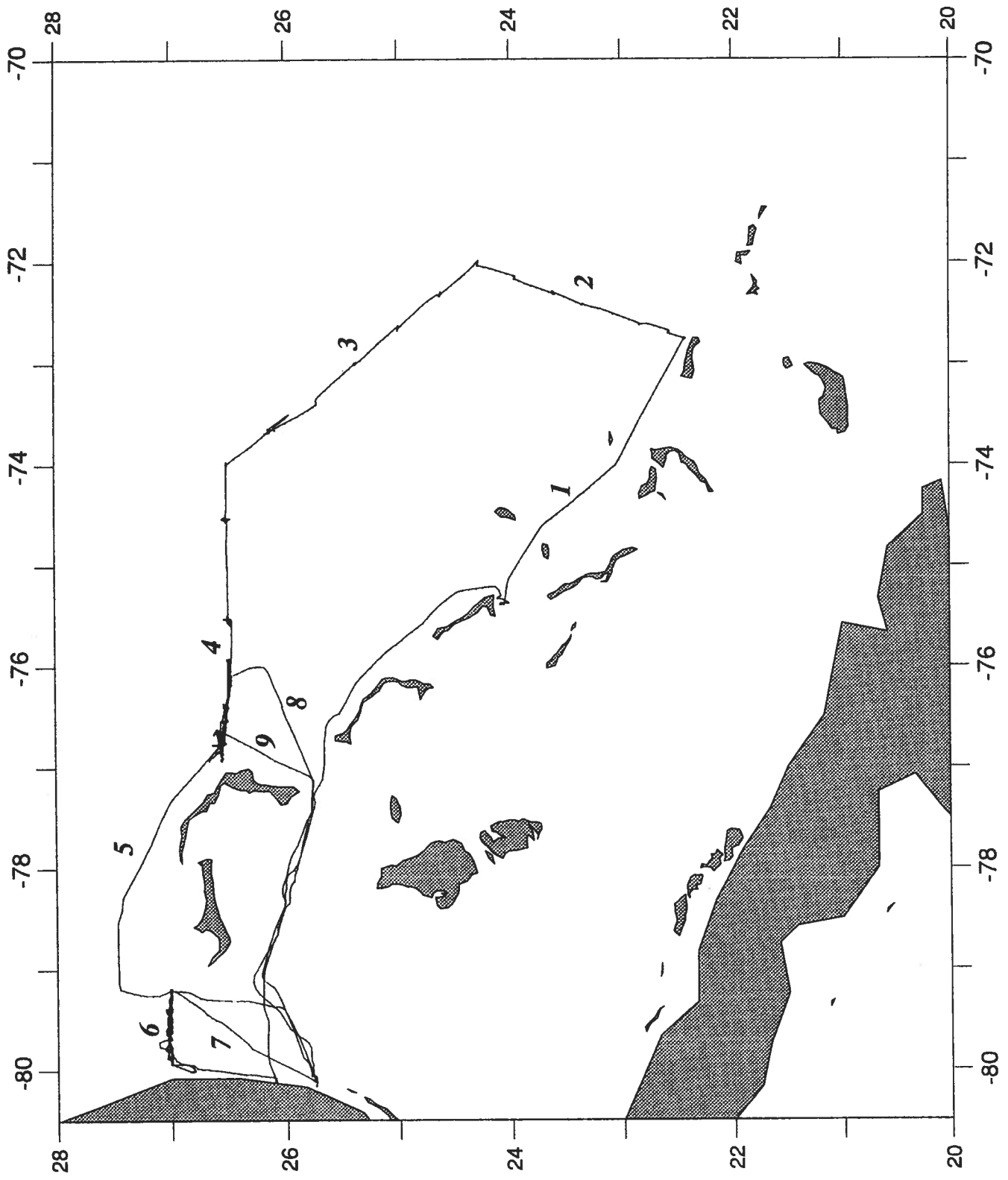

*Map of the Ametek-Straza (ADCP) trackline - March 1987*

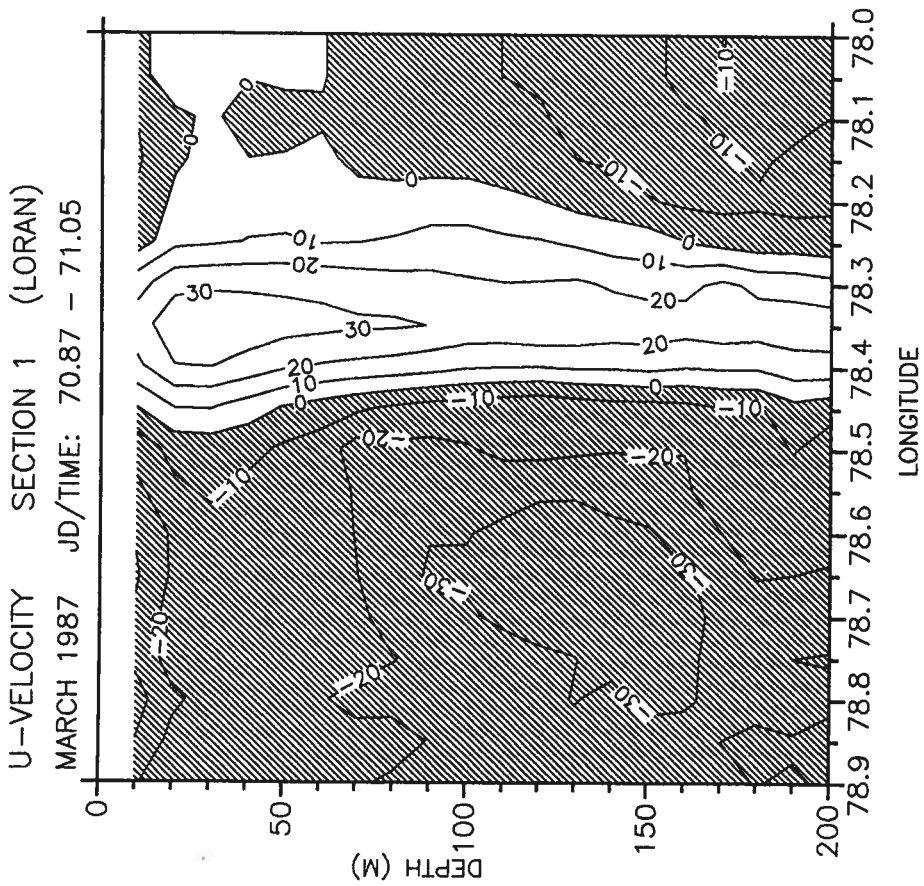
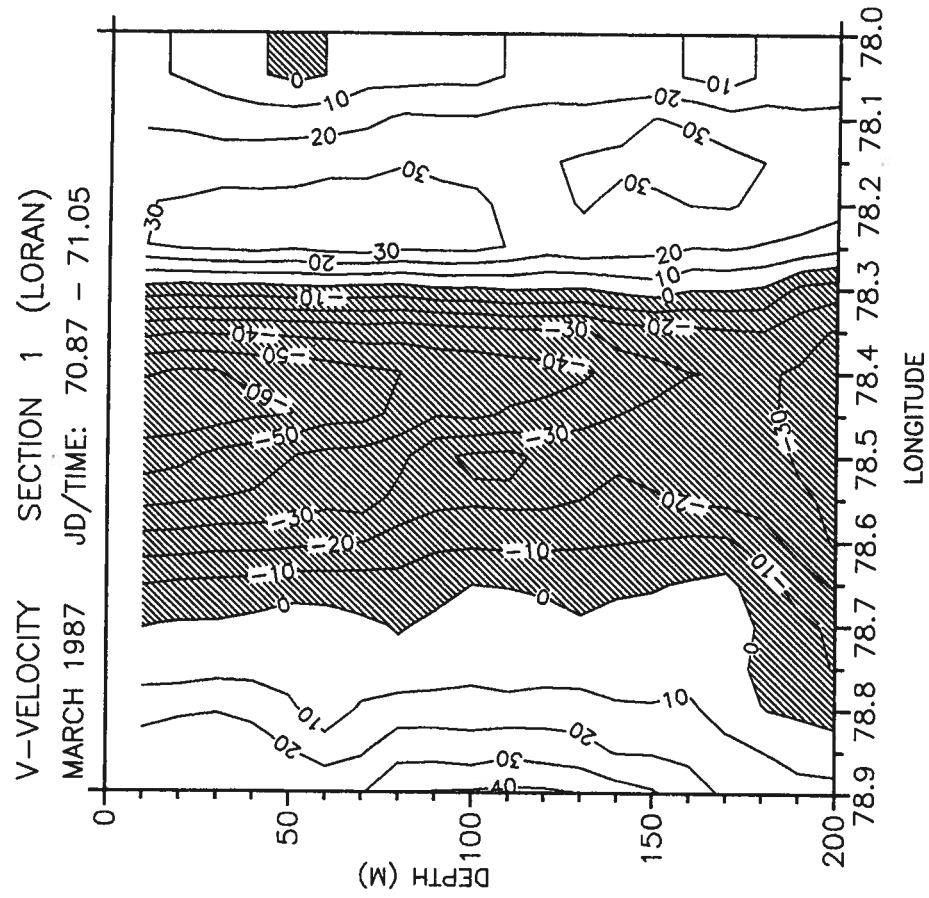

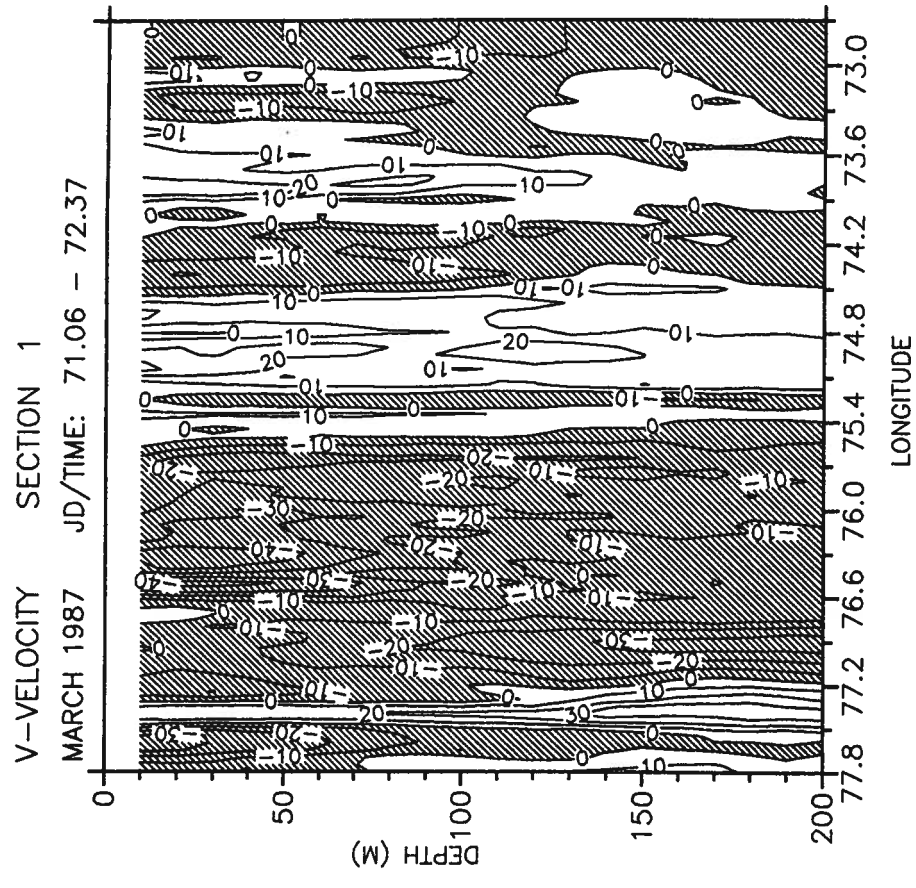
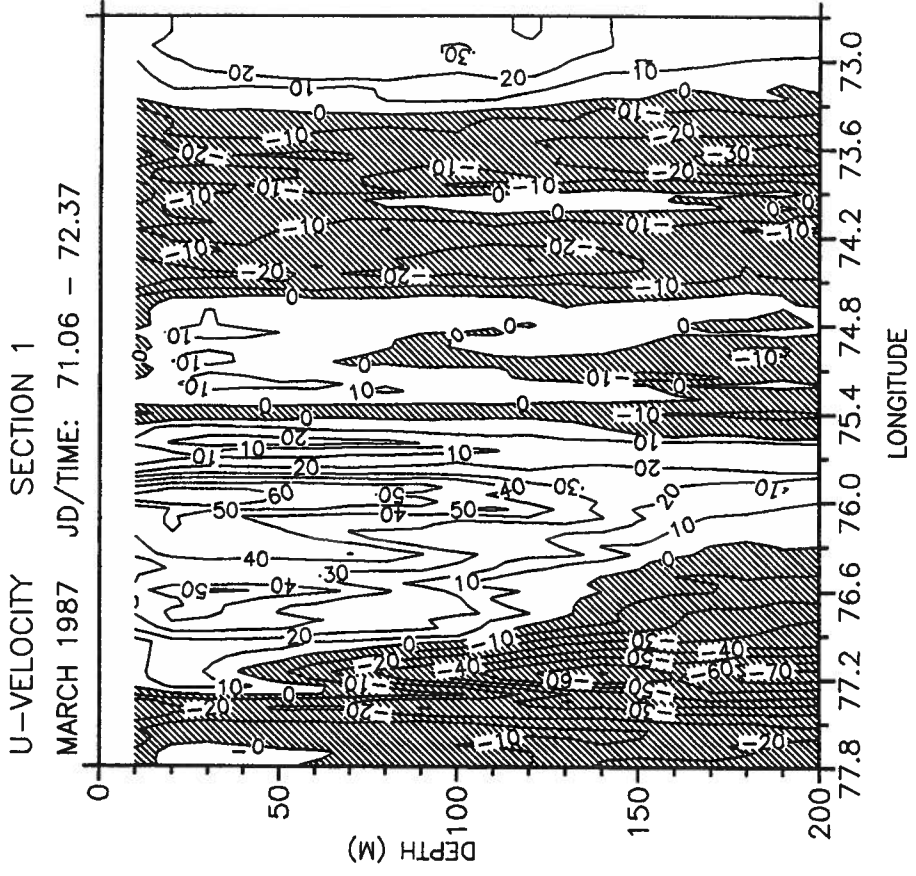

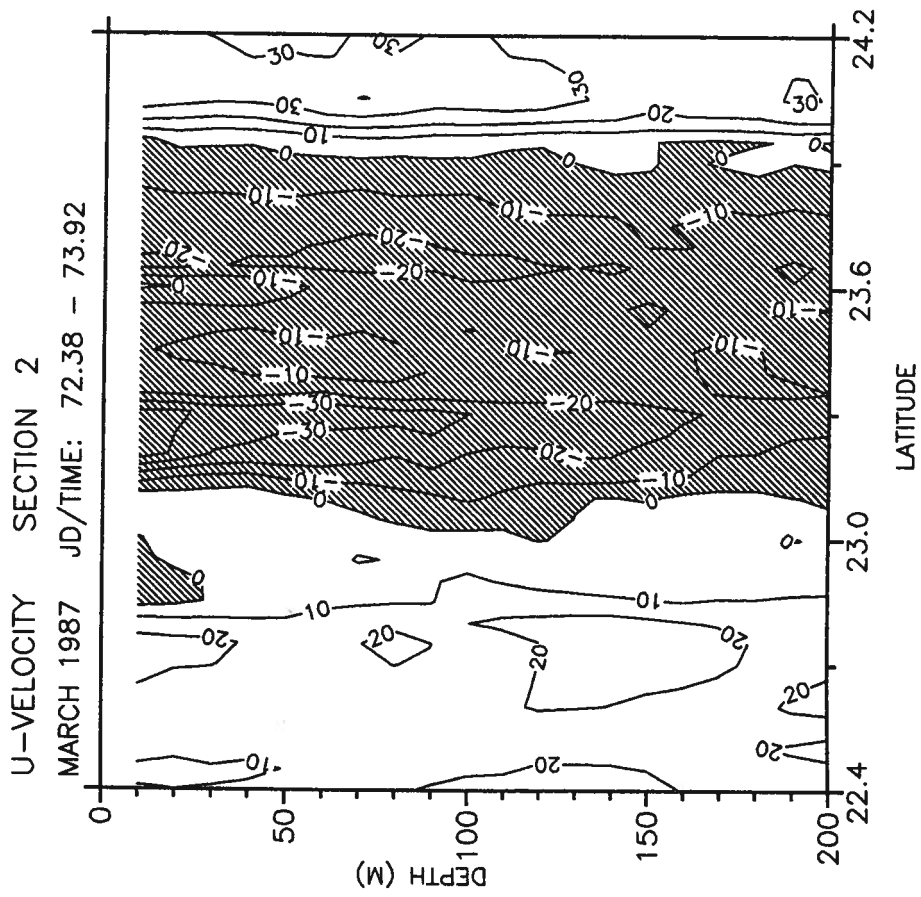
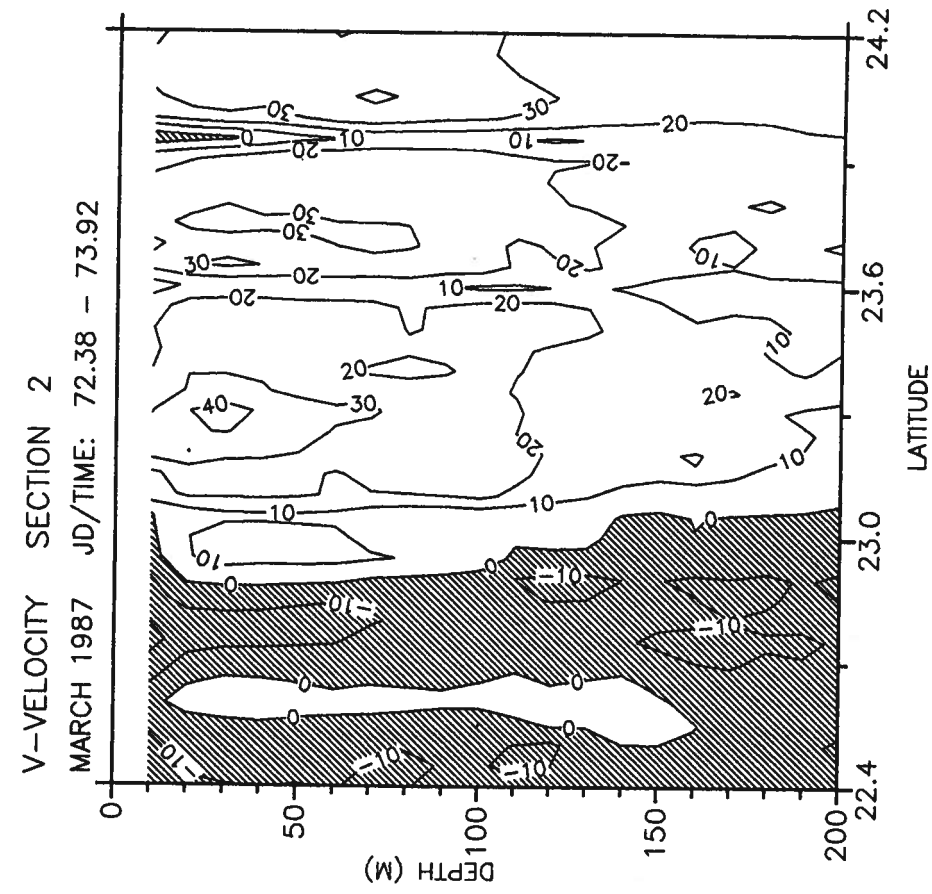

V-VELOCITY SECTION 3

MARCH 1987 JD/TIME: 73.93 - 75.73

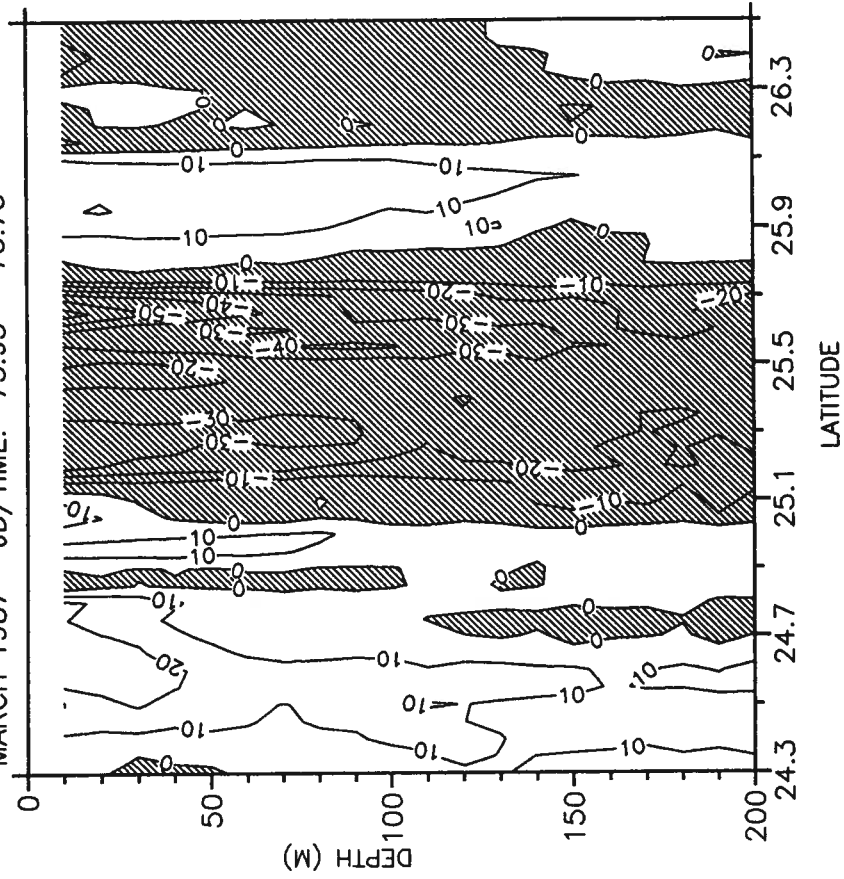

U-VELOCITY SECTION 3

MARCH 1987 JD/TIME: 73.93 - 75.73

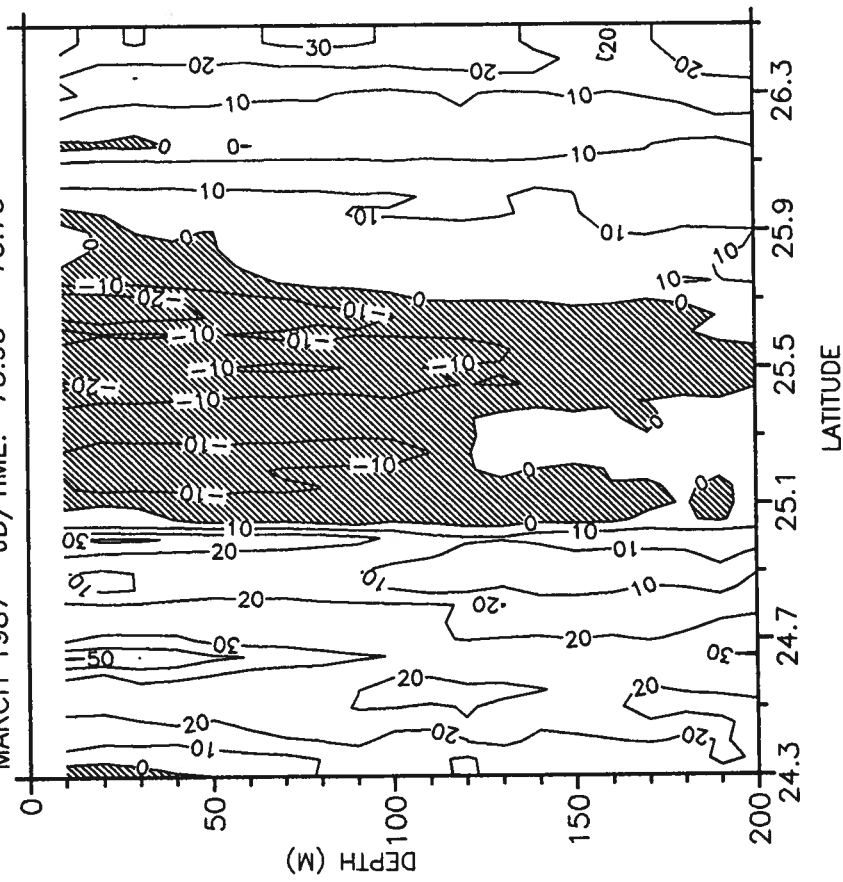

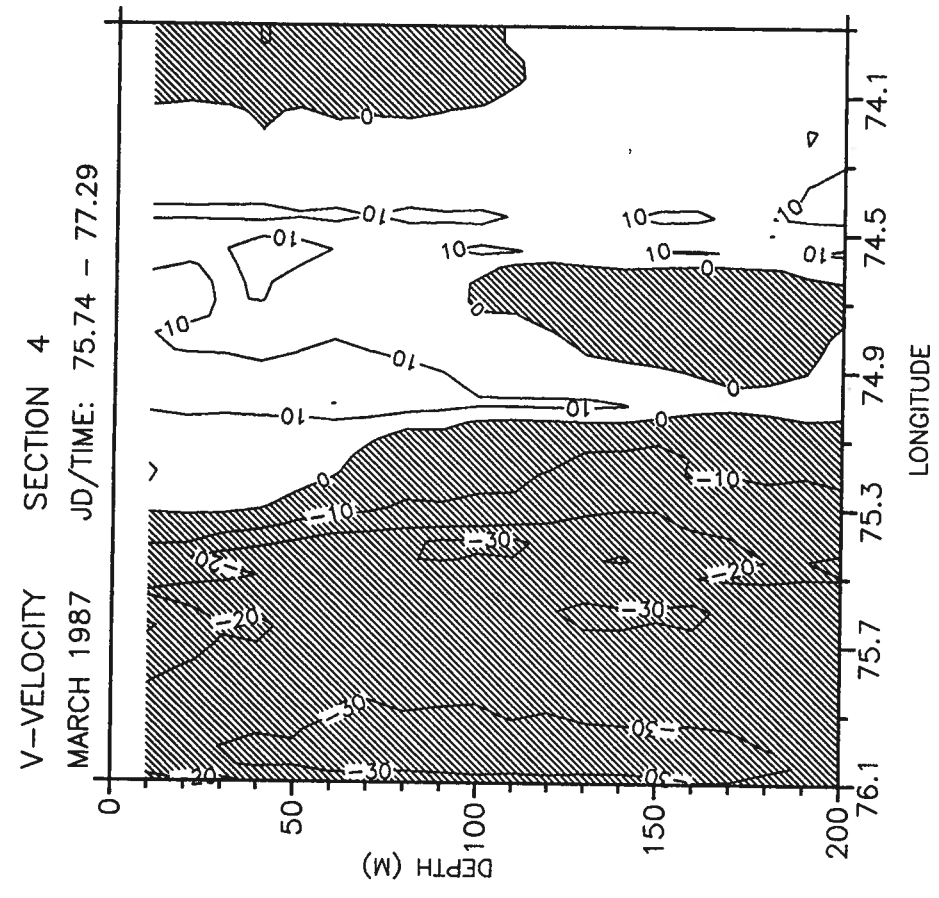
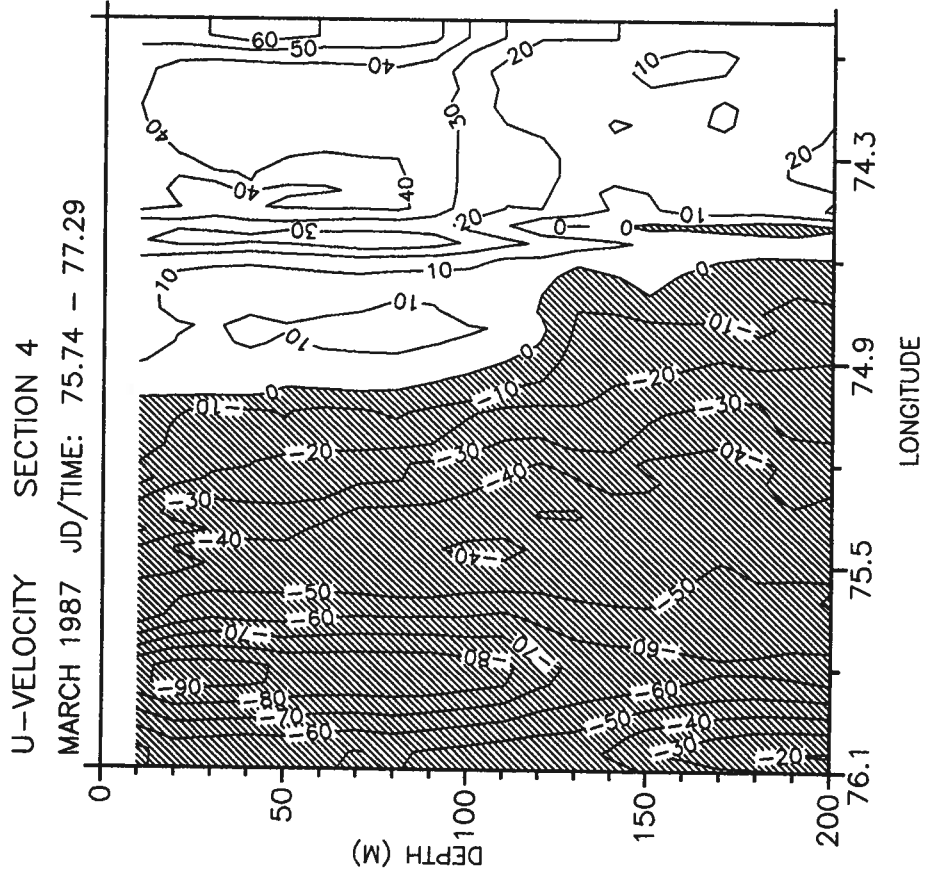

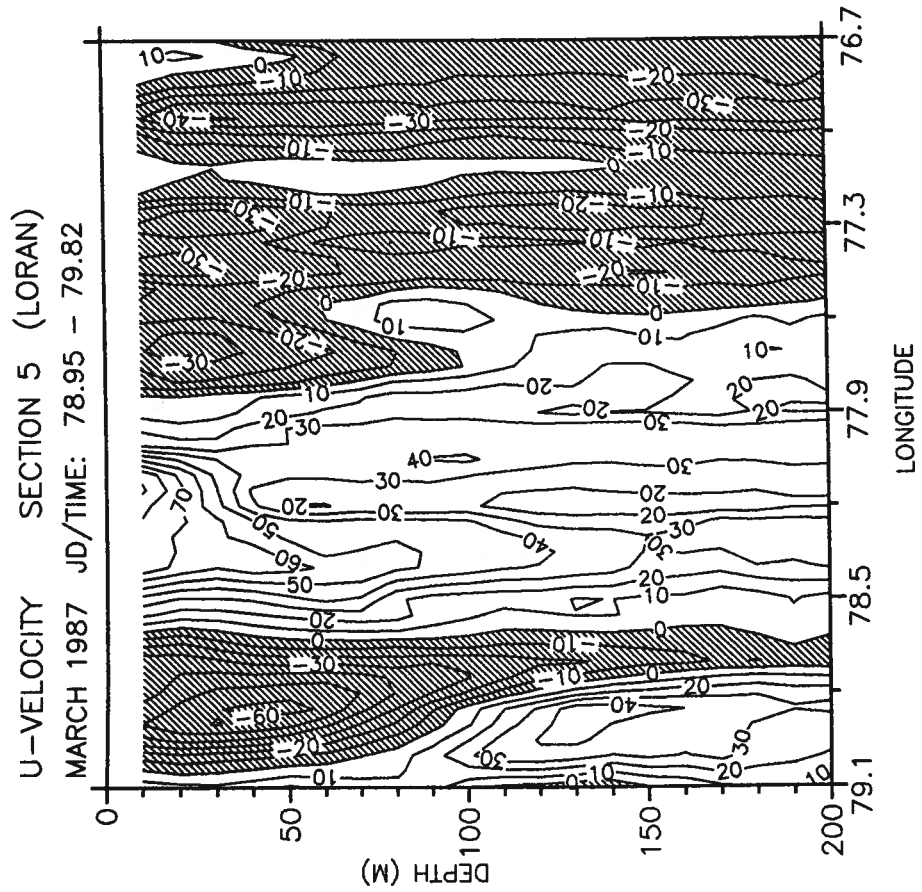
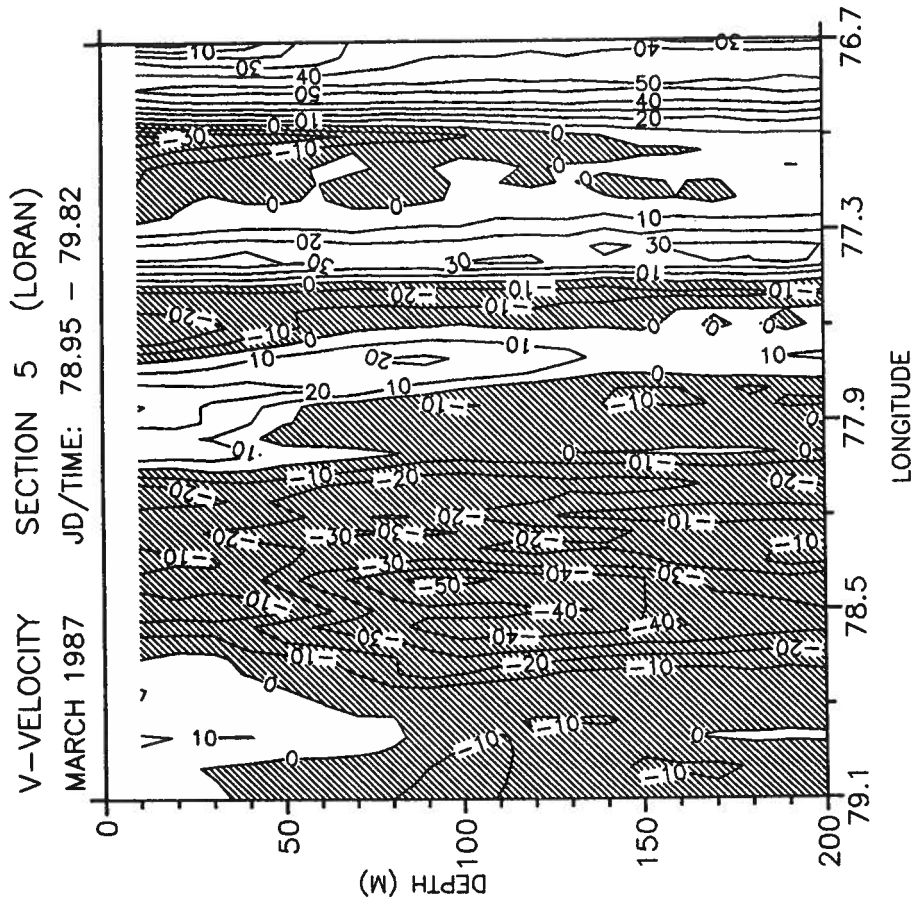



U-VELOCITY SECTION 6 (LORAN)

MARCH 1987 JD/TIME: 80.64 - 81.09

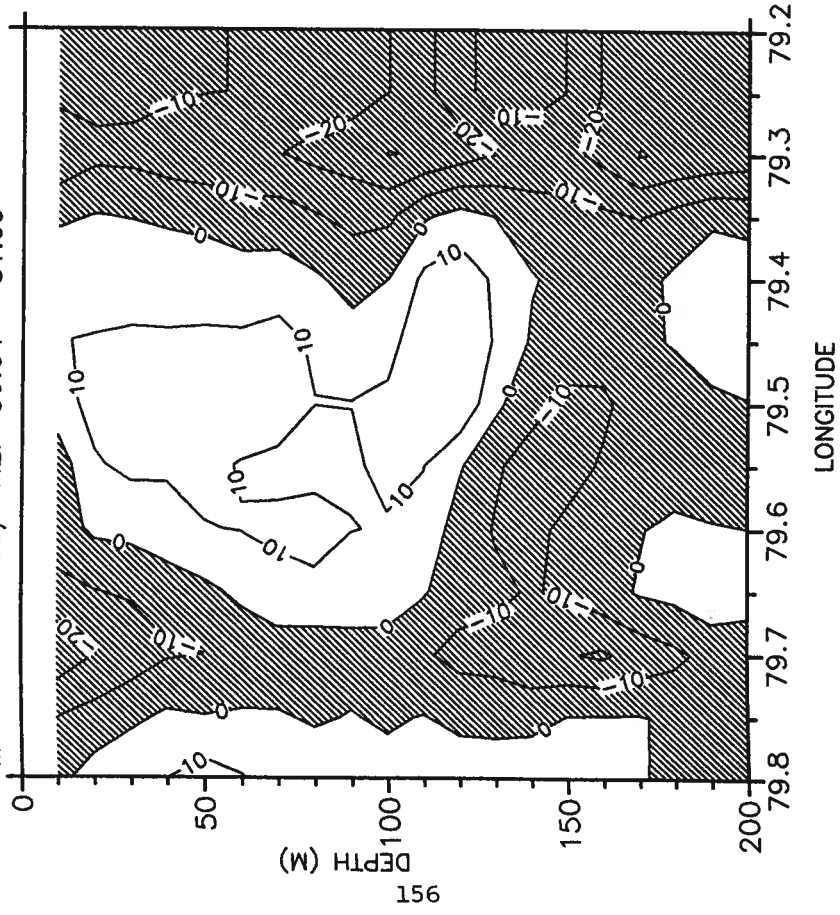

V-VELOCITY SECTION 6 (LORAN)

MARCH 1987 JD/TIME: 80.64 - 81.09

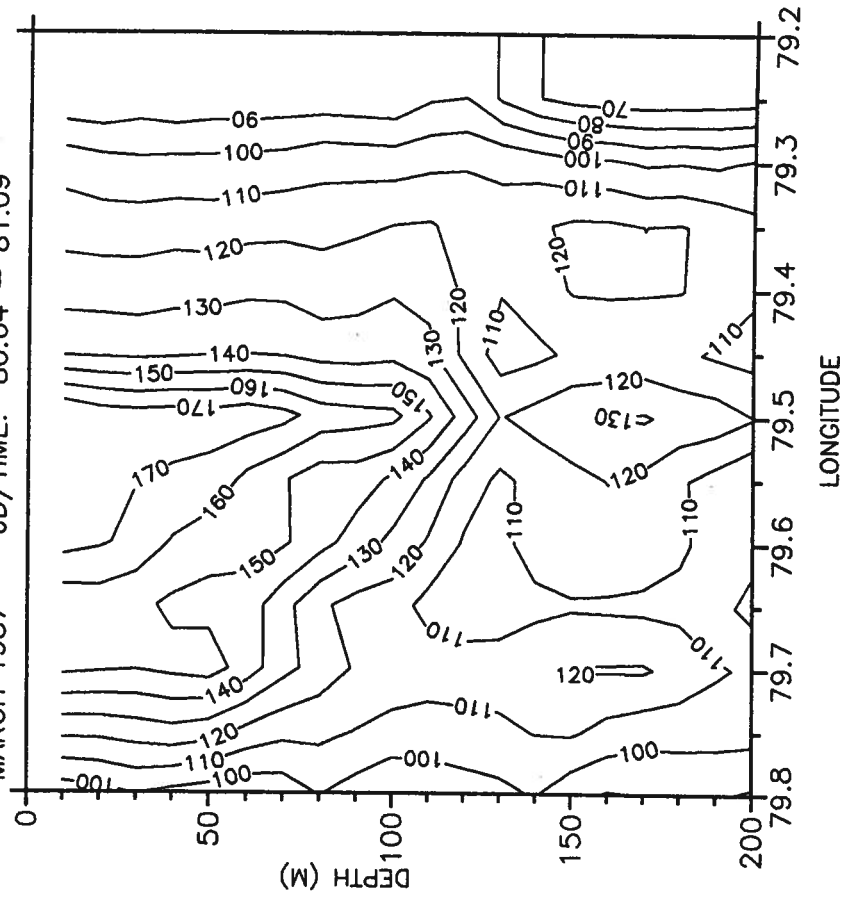

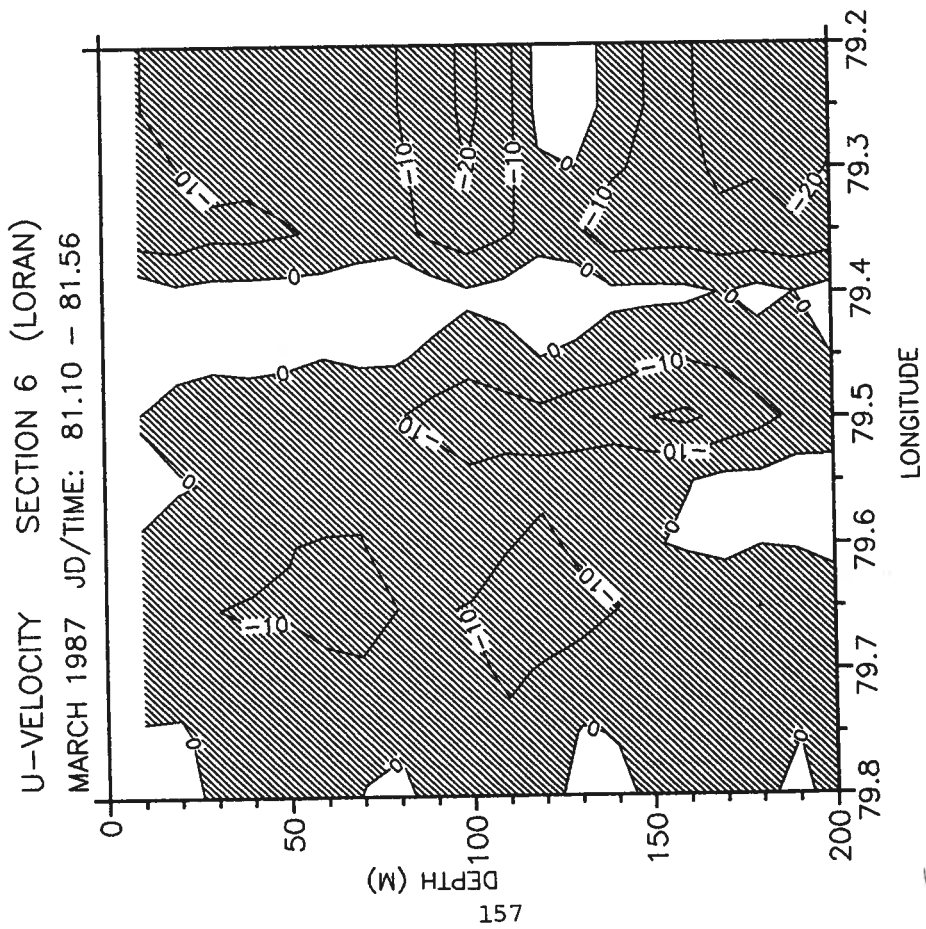
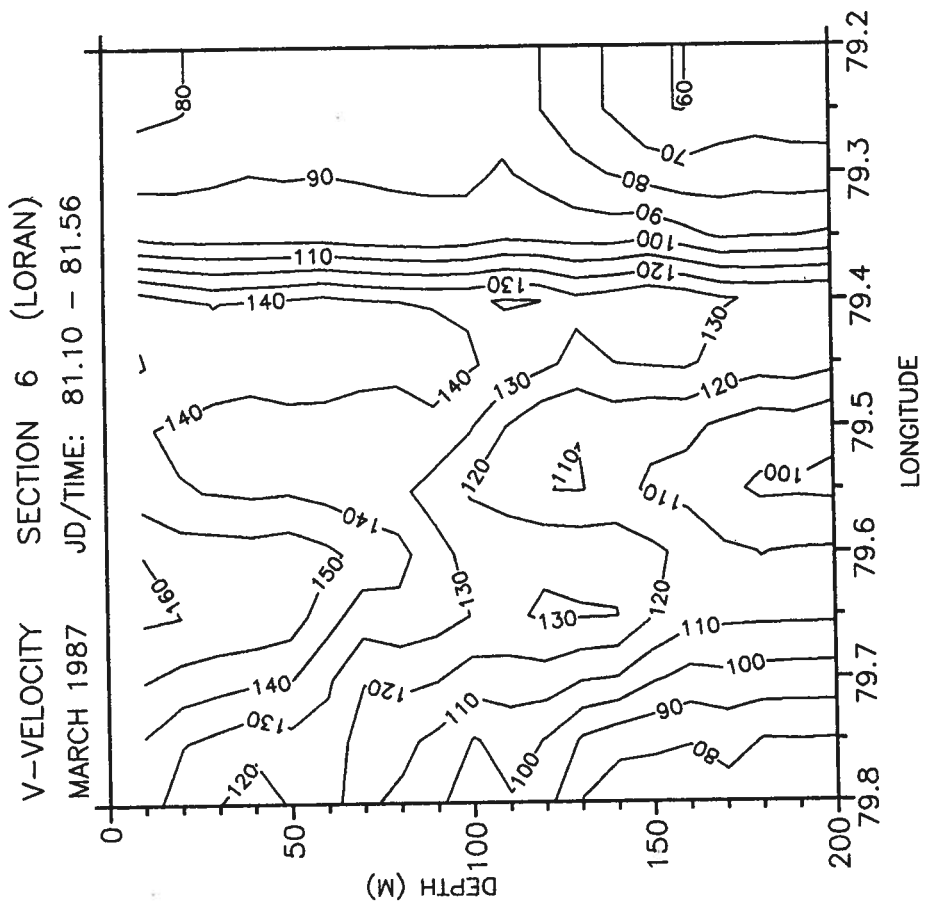

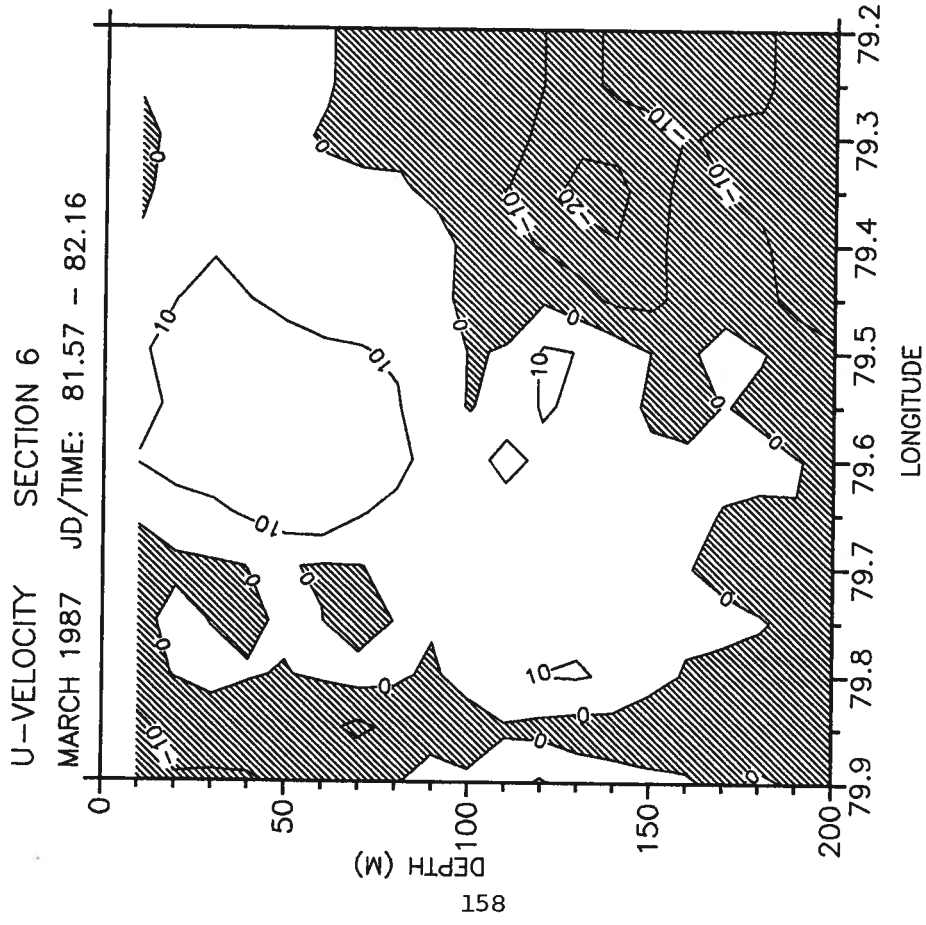
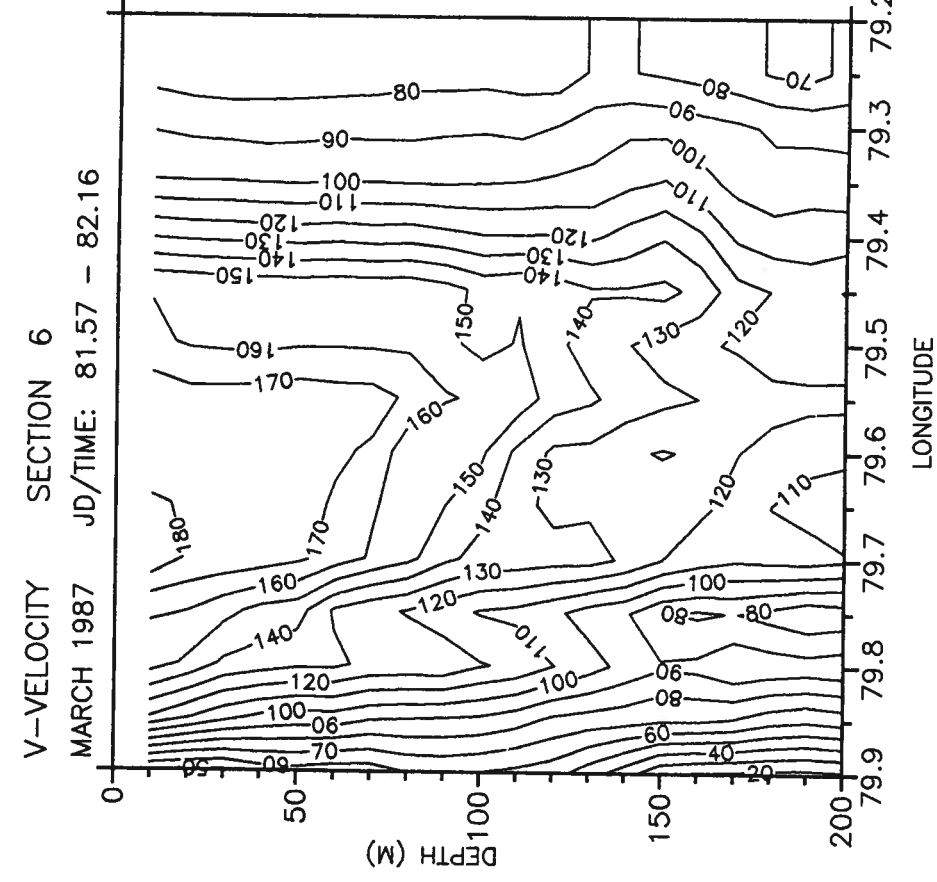

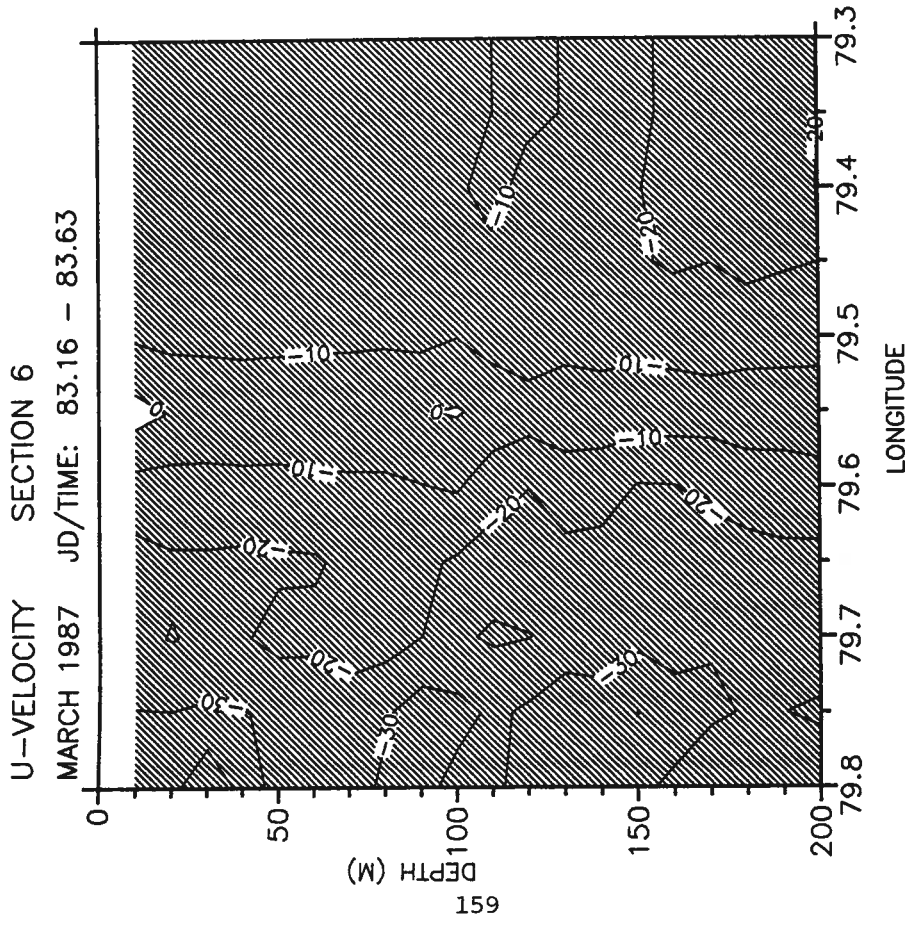
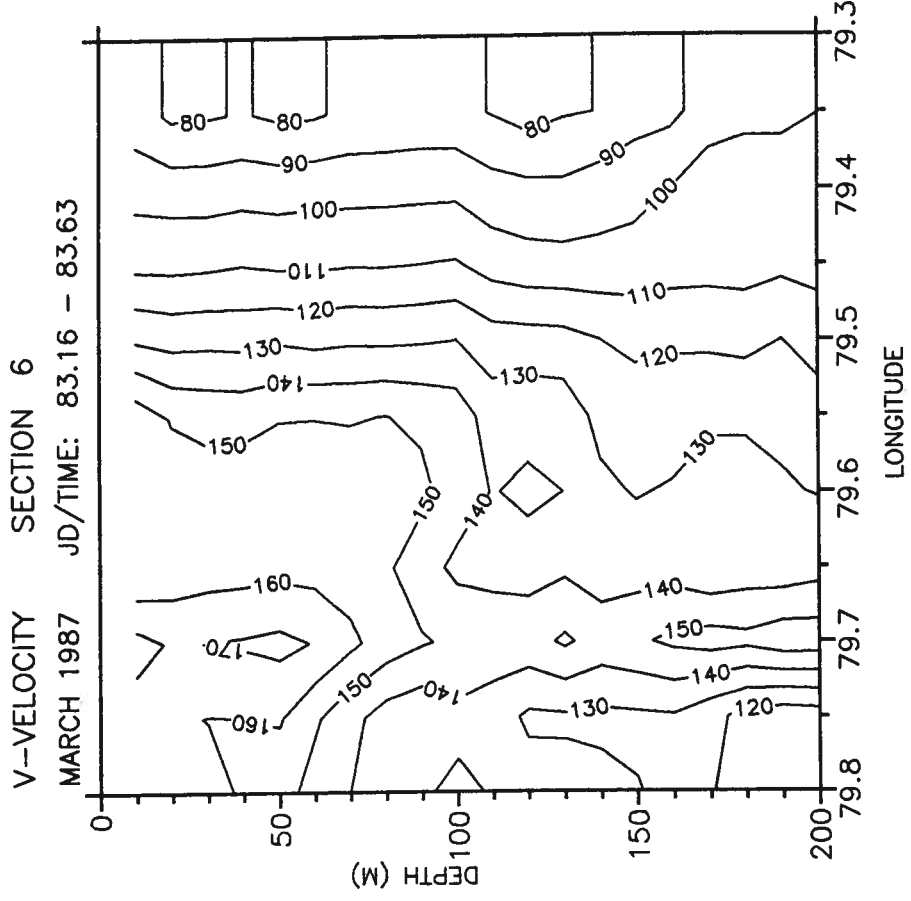

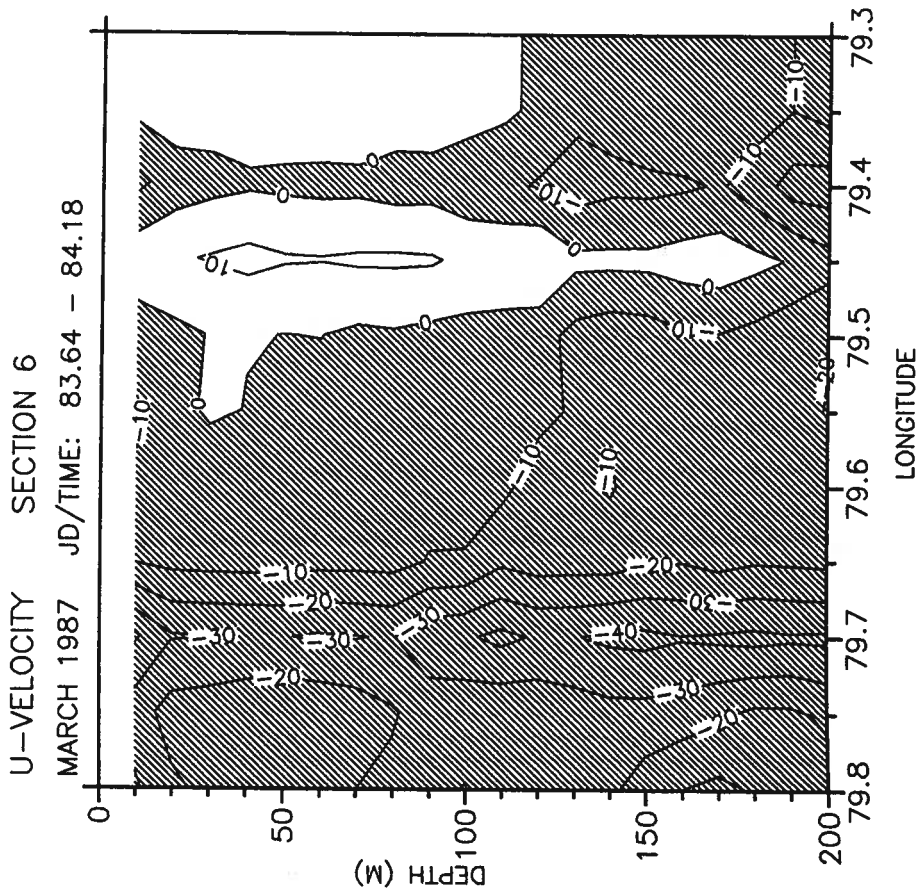
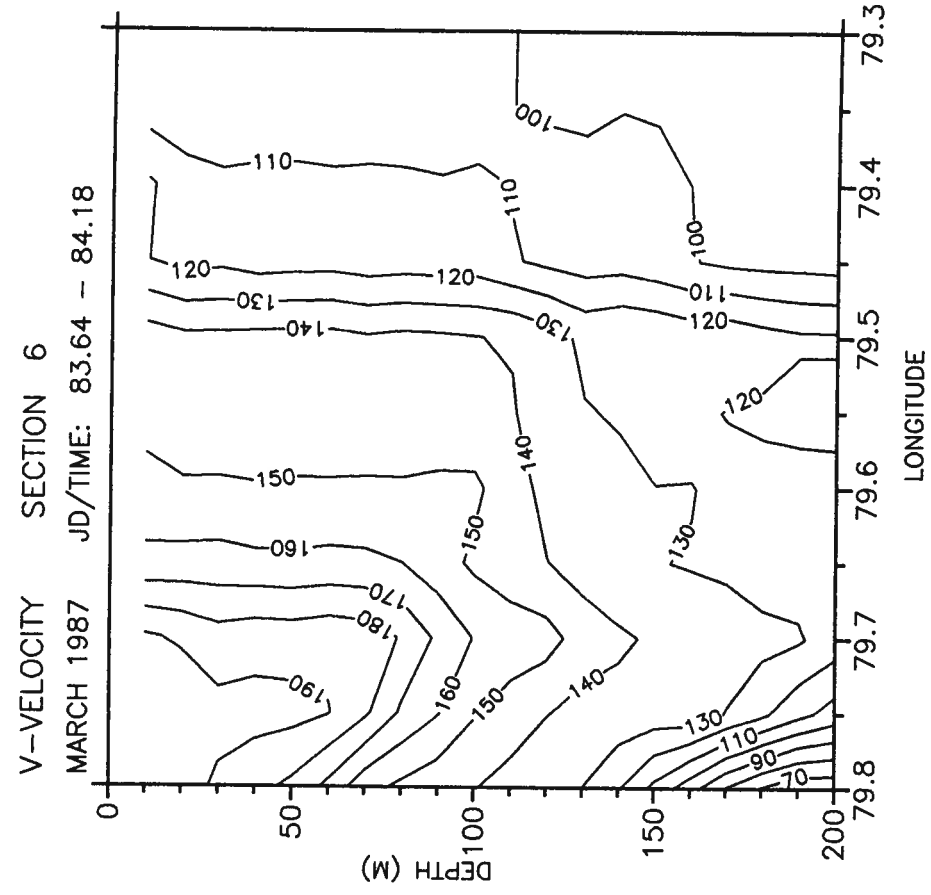

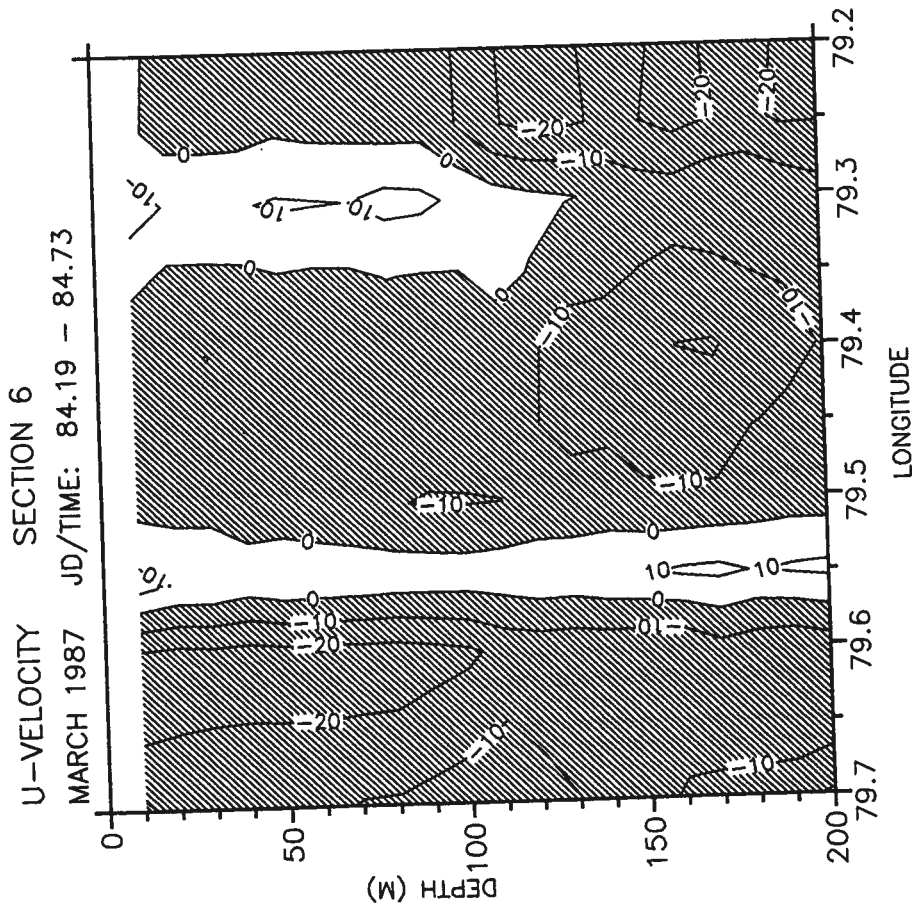
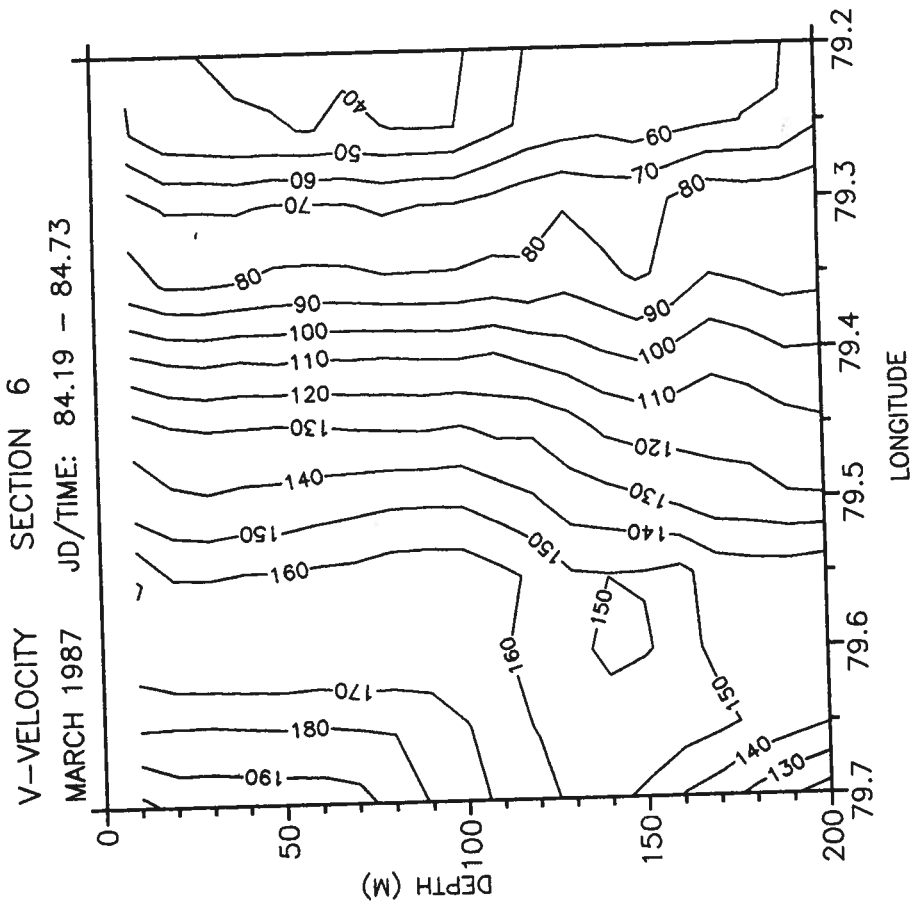

U-VELOCITY SECTION 7 (LORAN)

MARCH 1987 JD/TIME: 82.92 - 83.15

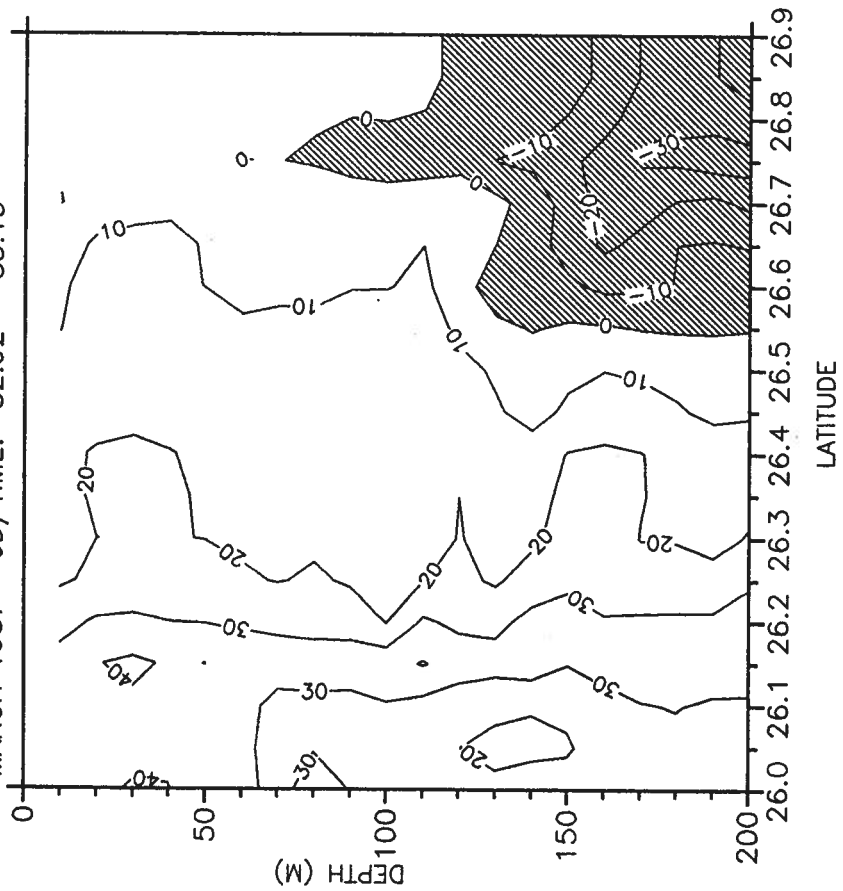

V-VELOCITY SECTION 7 (LORAN)

MARCH 1987 JD/TIME: 82.92 - 83.15

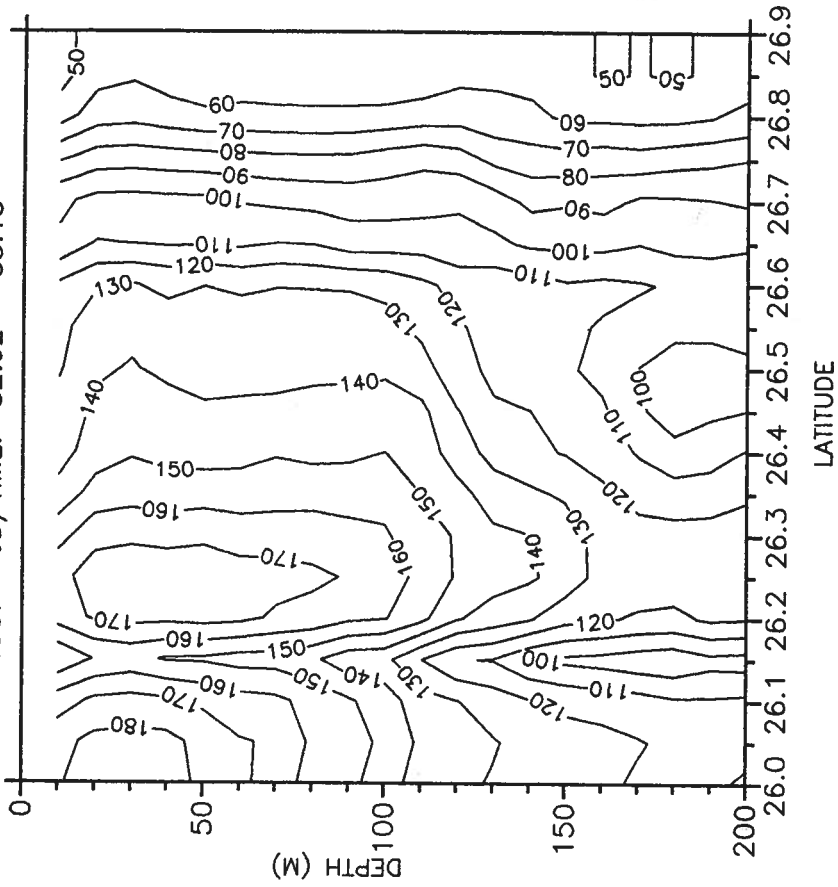

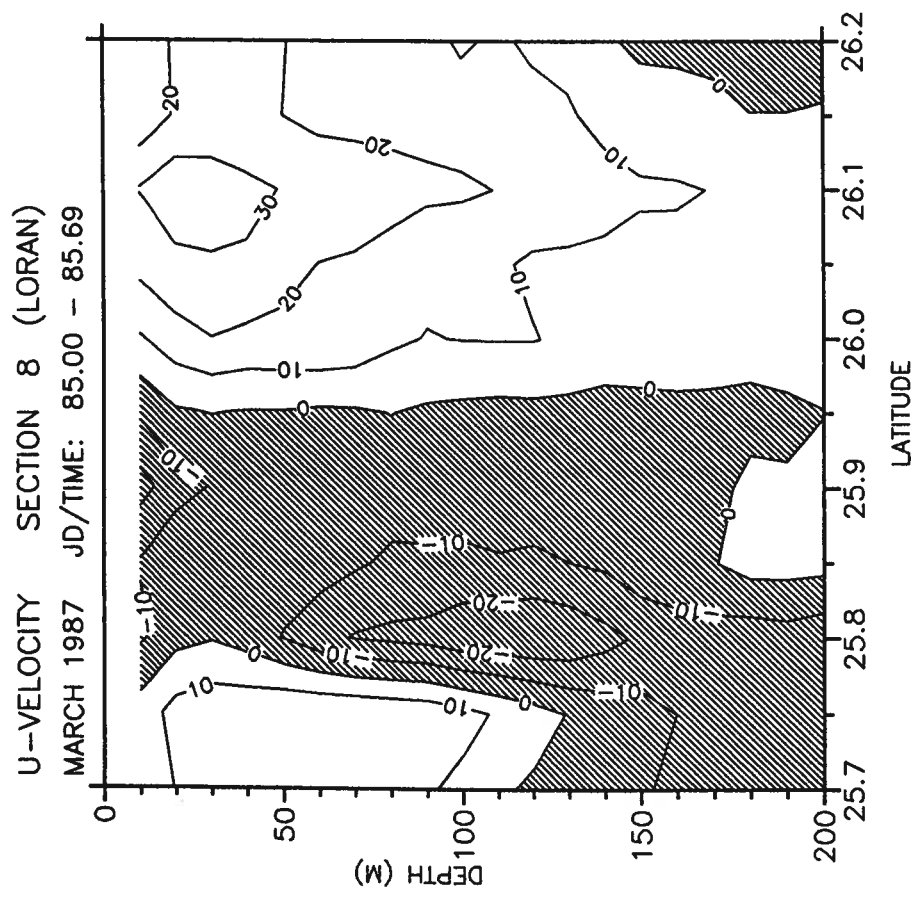
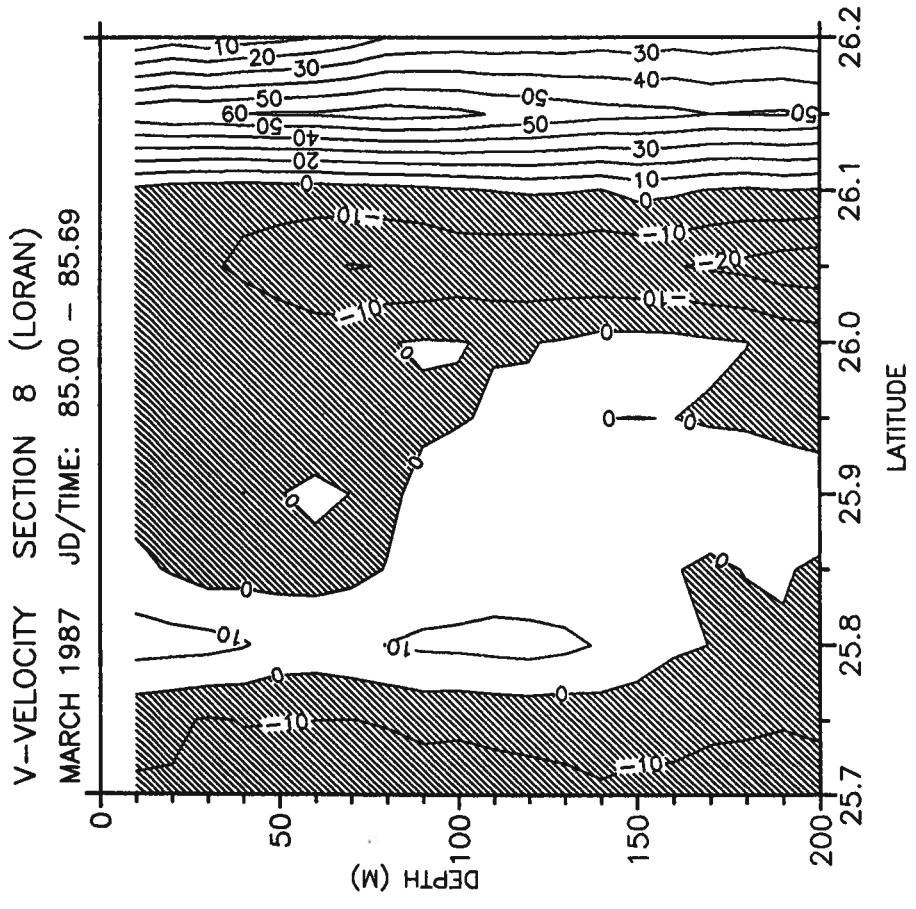



U-VELOCITY SECTION 9 (LORAN)  
MARCH 1987 JD/TIME: 88.75 - 89.09

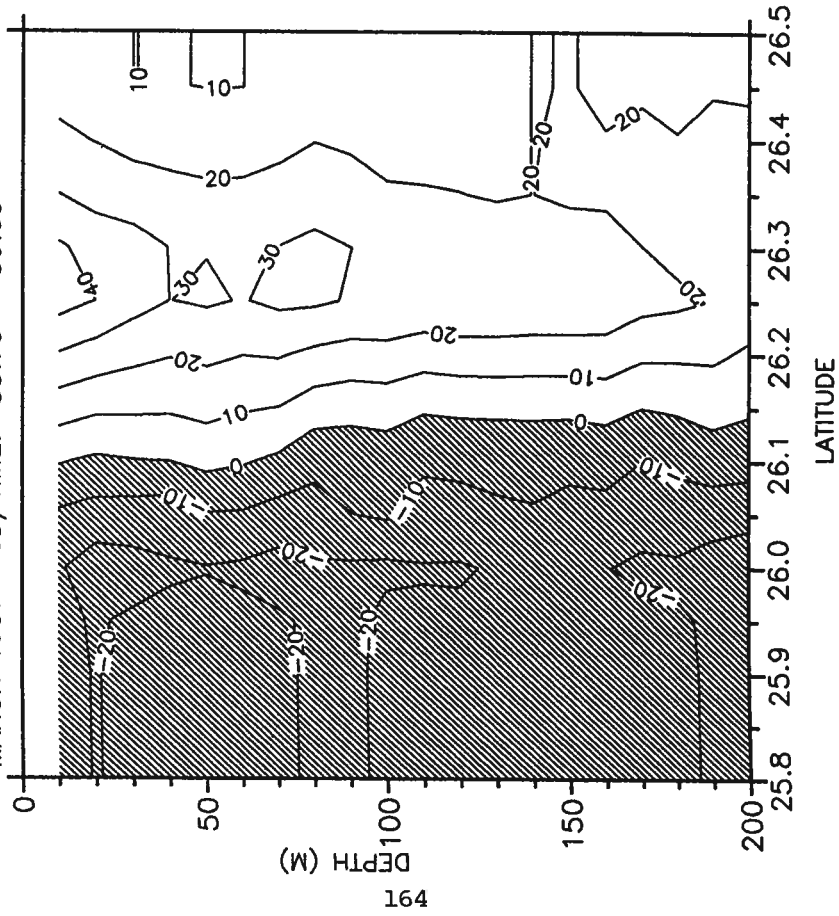

V-VELOCITY SECTION 9 (LORAN)  
MARCH 1987 JD/TIME: 88.75 - 89.09

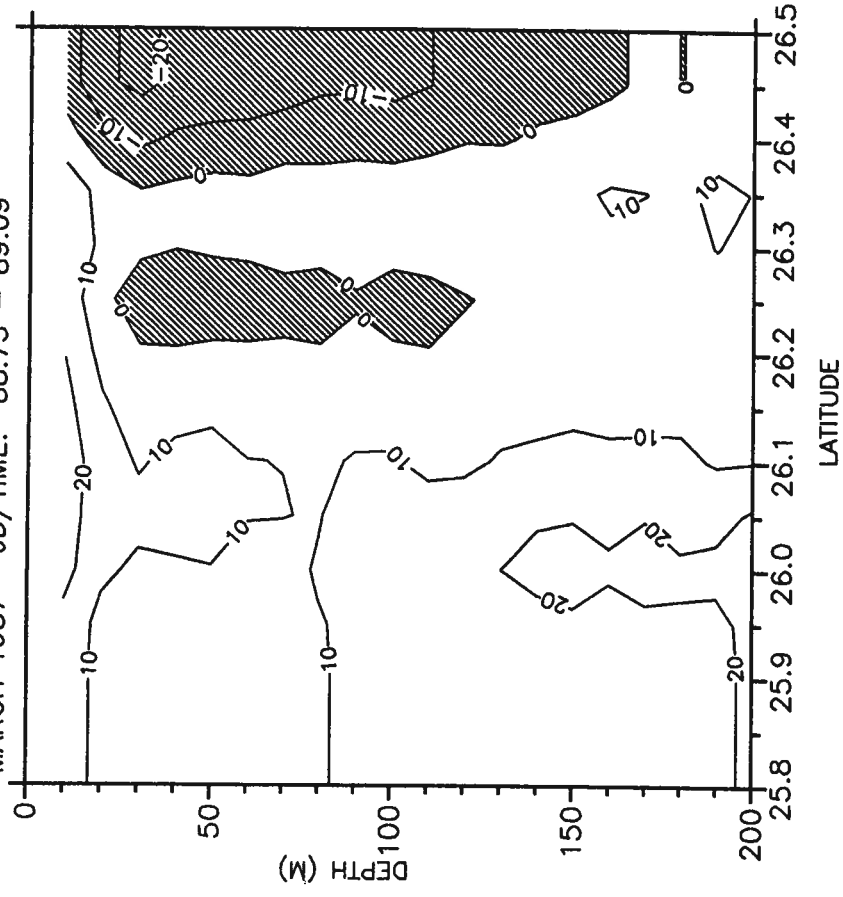

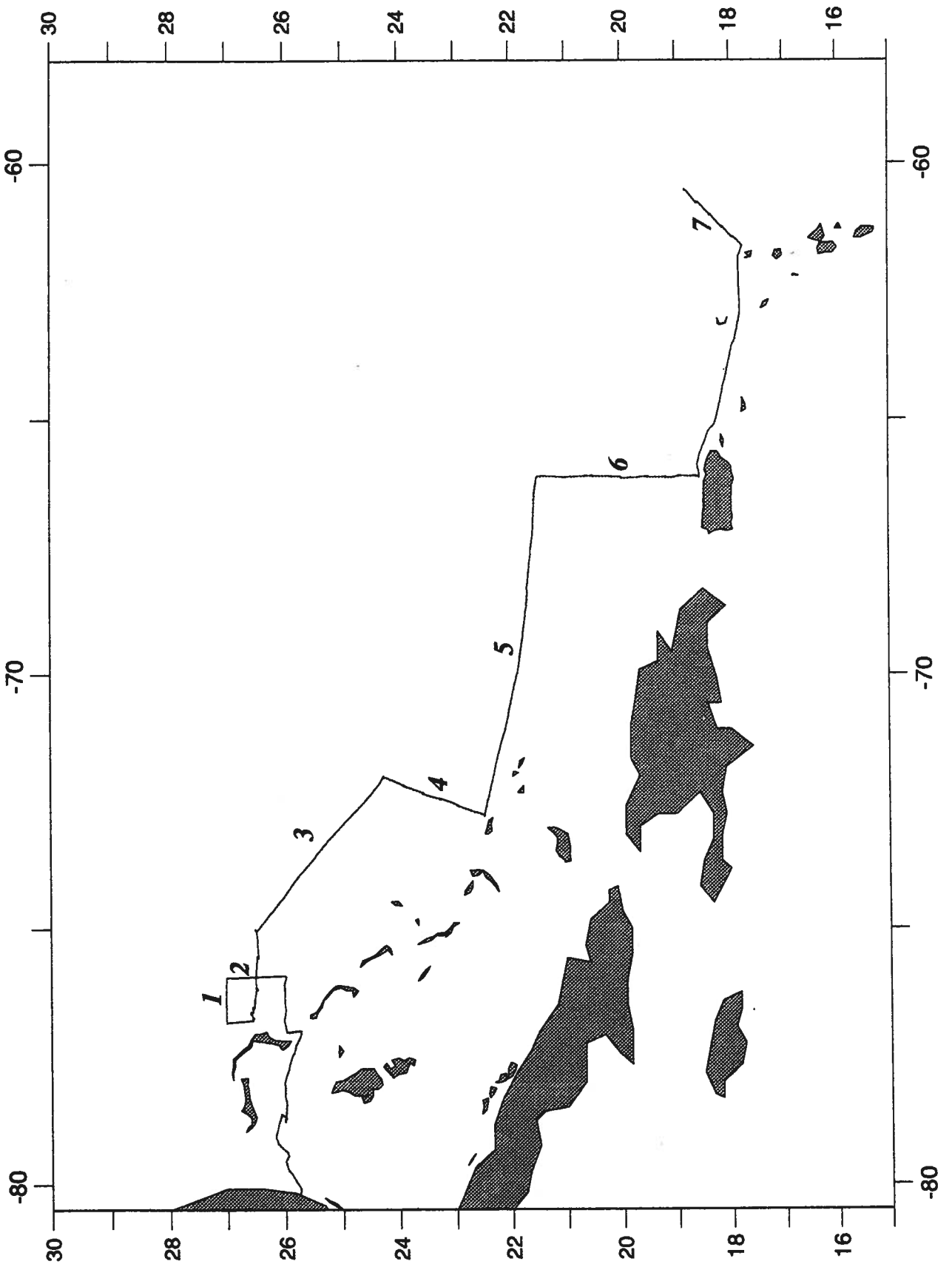

*Map of the Ametek-Straza (ADCP) trackline - September 1987 (Leg I)*

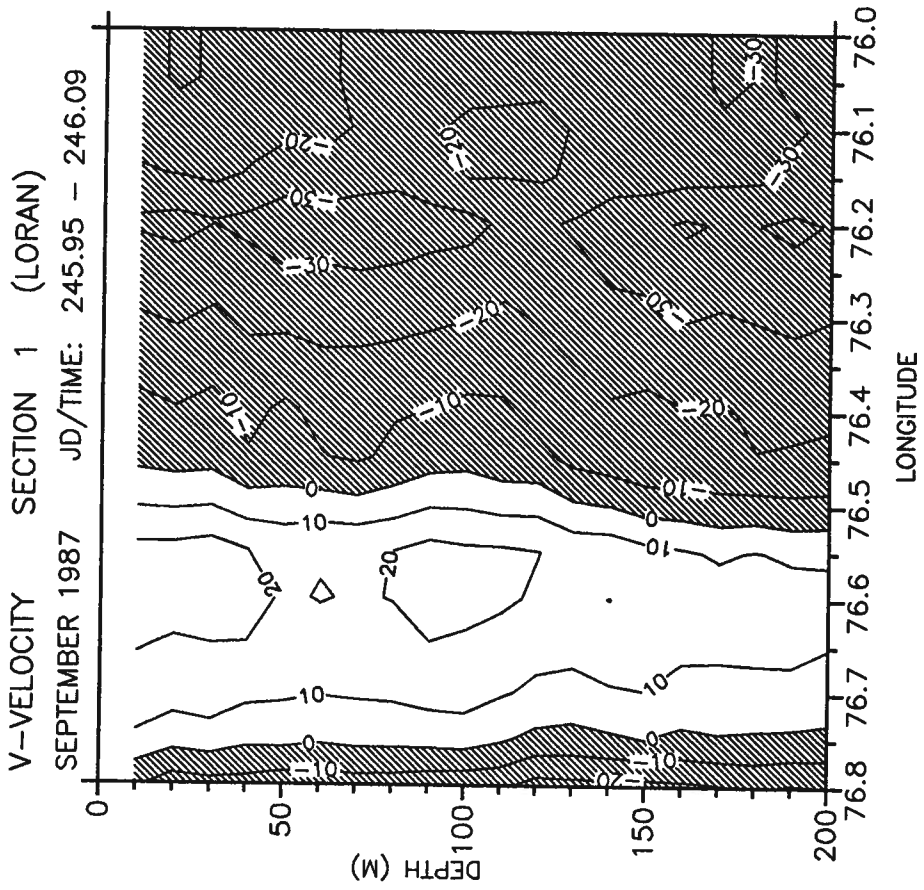
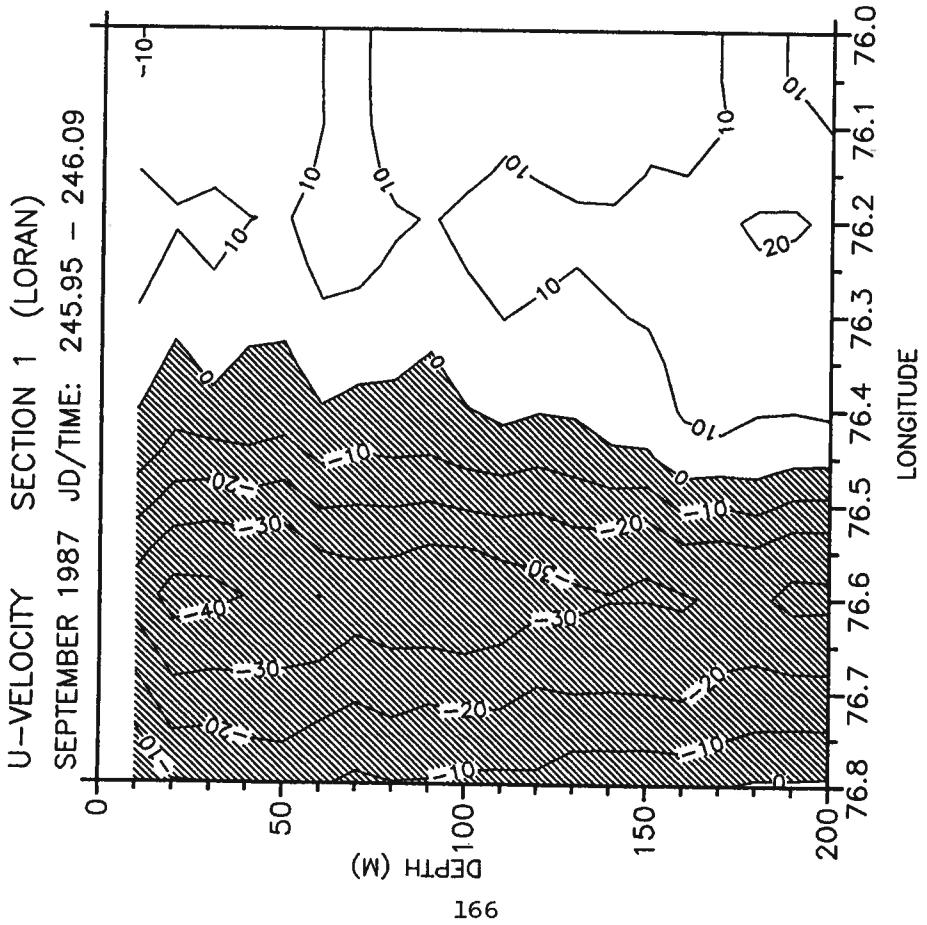

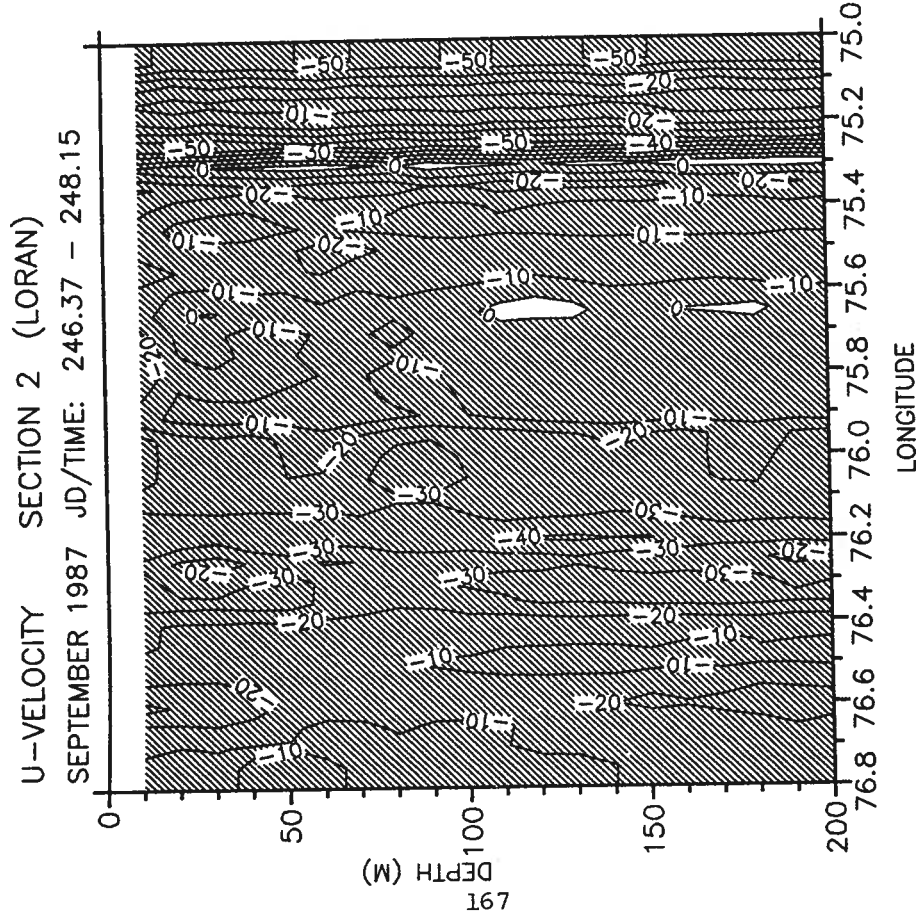
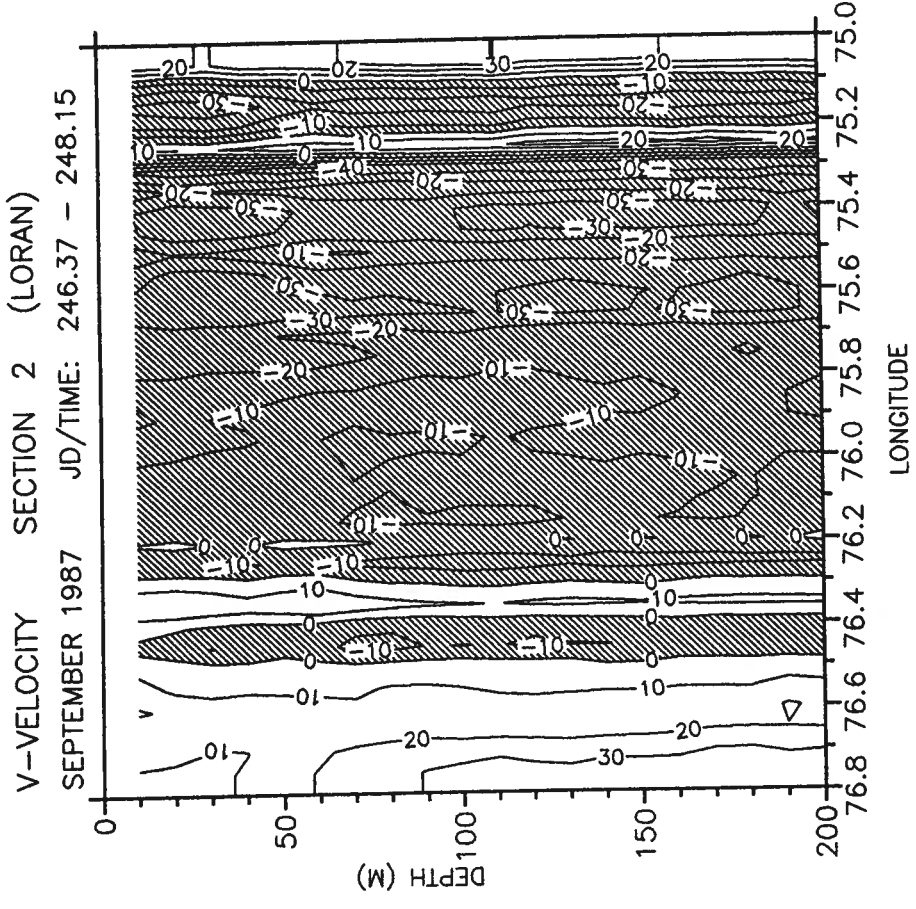

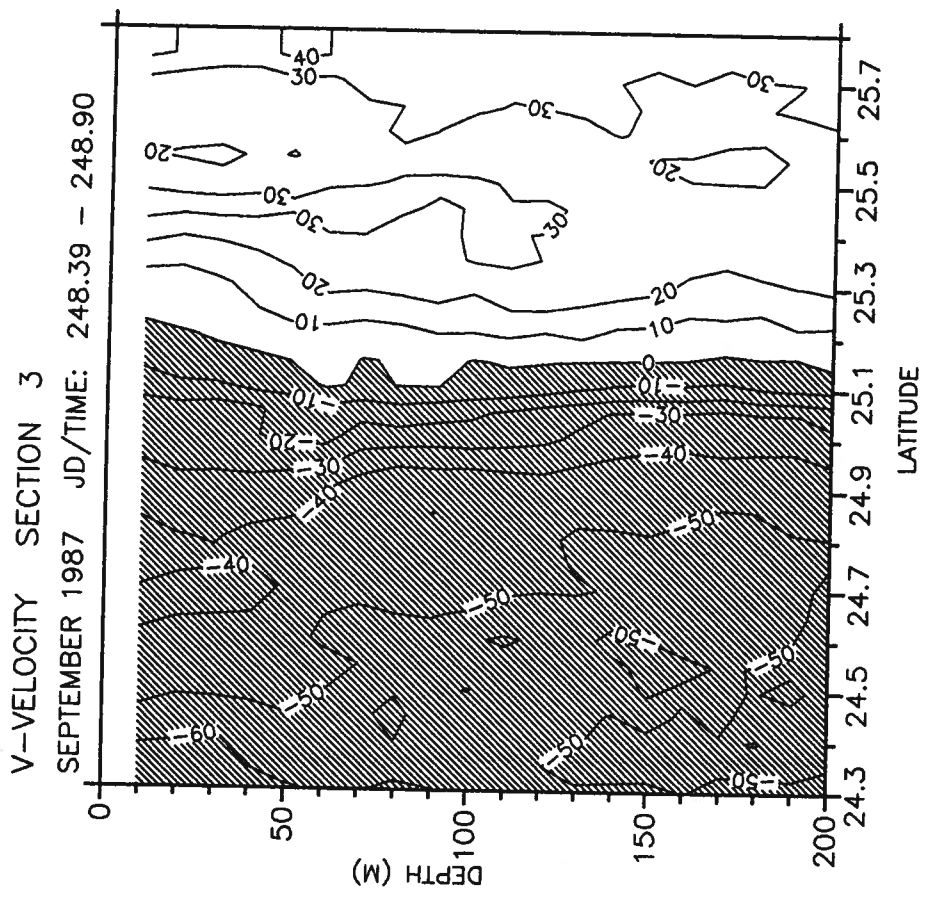
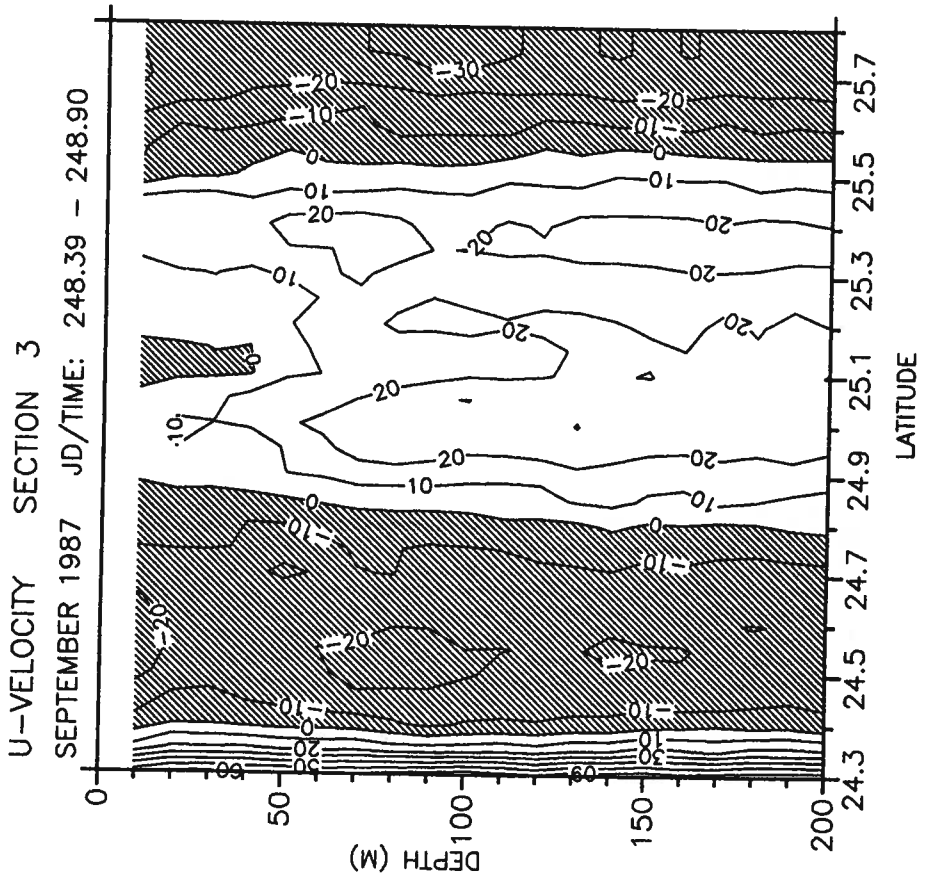

V-VELOCITY SECTION 4

SEPTEMBER 1987 JD/TIME: 248.91 - 250.05

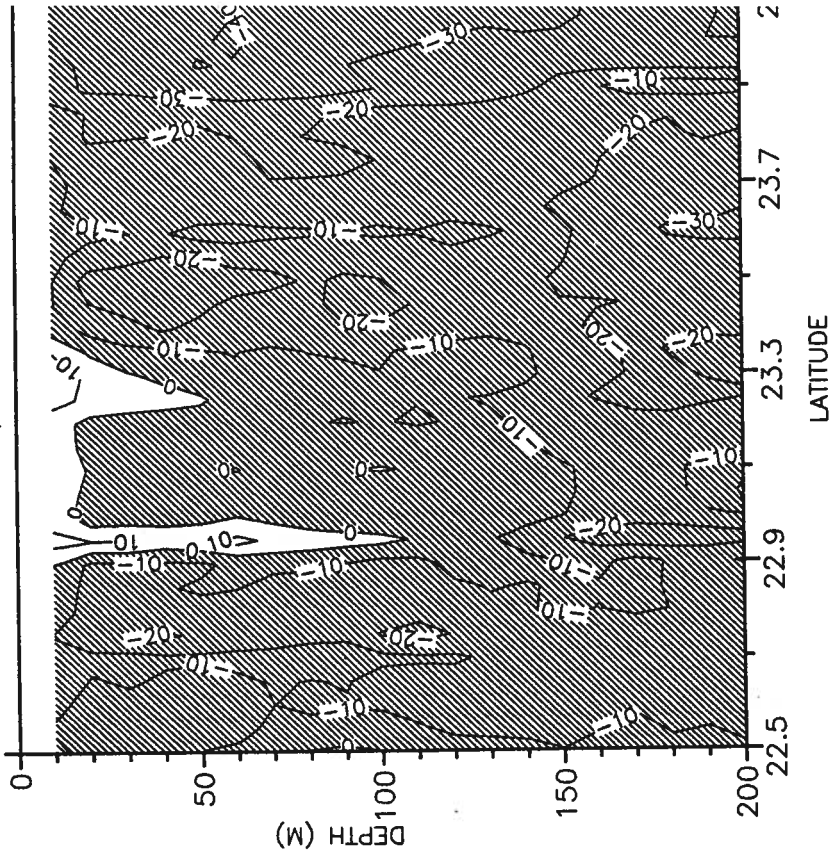

U-VELOCITY SECTION 4

SEPTEMBER 1987 JD/TIME: 248.91 - 250.05

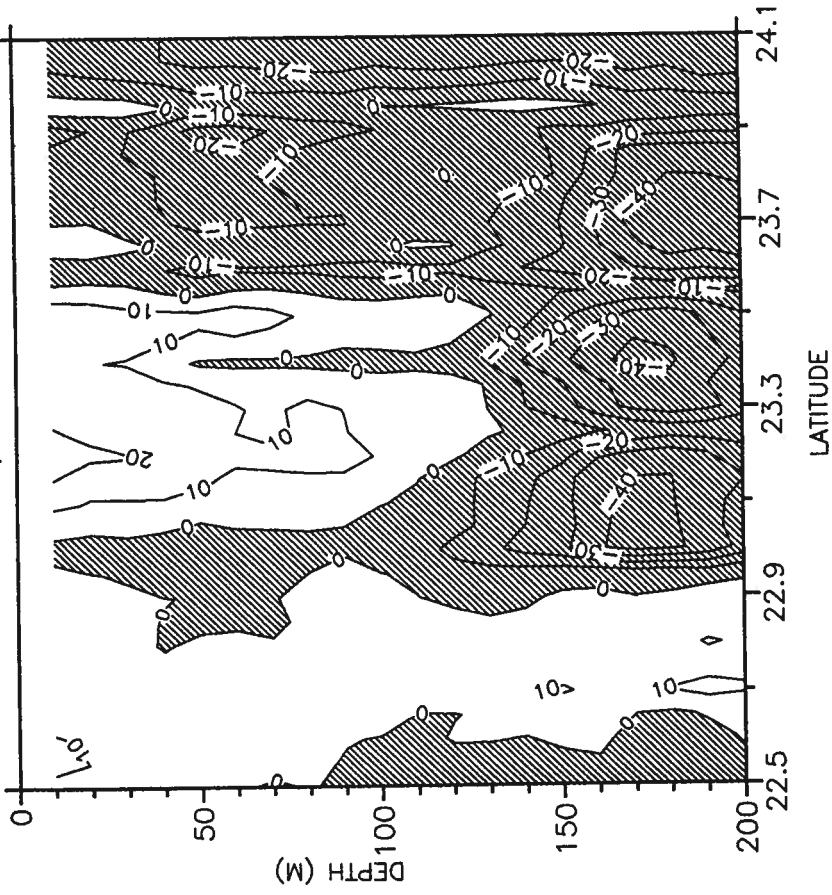

V-VELOCITY SECTION 5

SEPTEMBER 1987 JD/TIME: 250.06 - 251.23

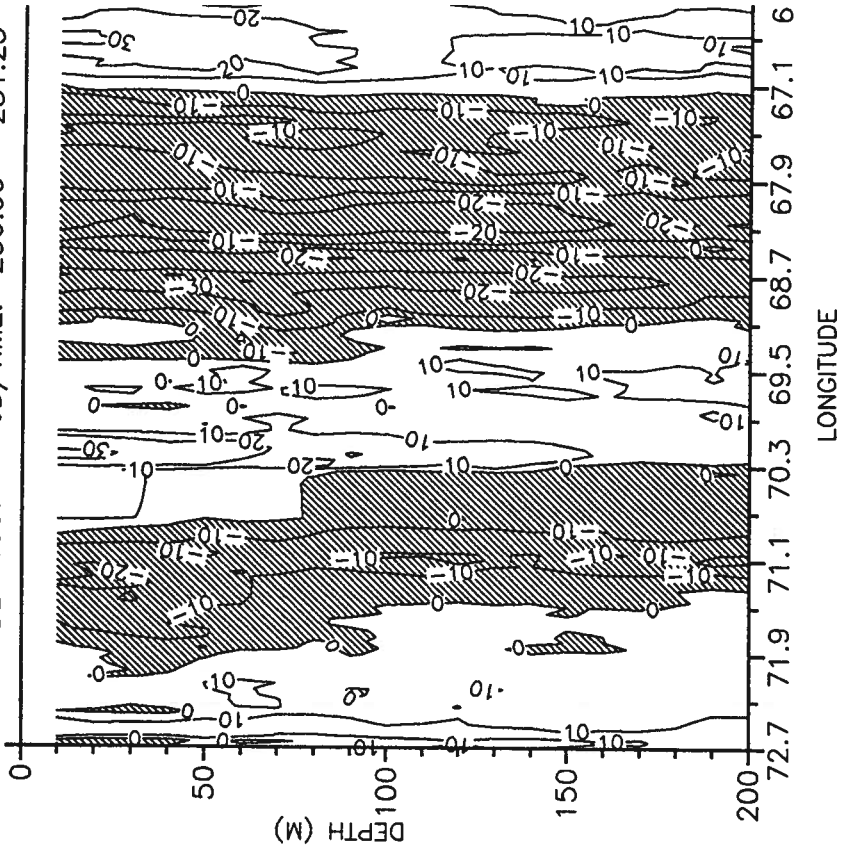

U-VELOCITY SECTION 5

SEPTEMBER 1987 JD/TIME: 250.06 - 251.23

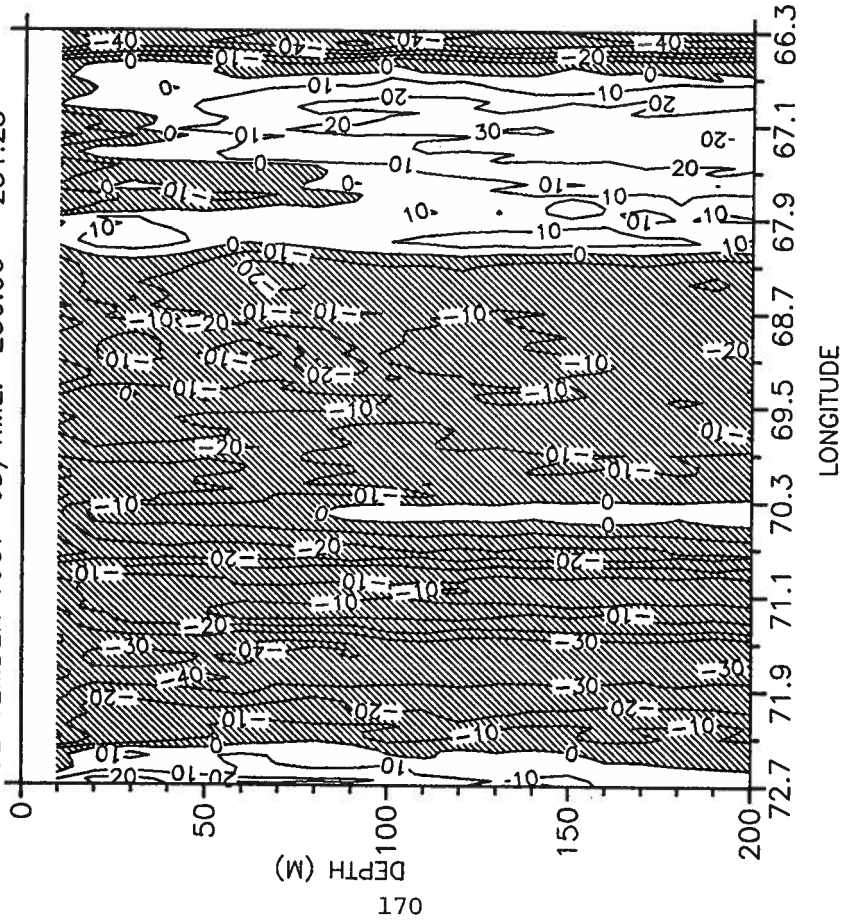



U-VELOCITY SECTION 6

SEPTEMBER 1987 JD/TIME: 251.24 - 252.69

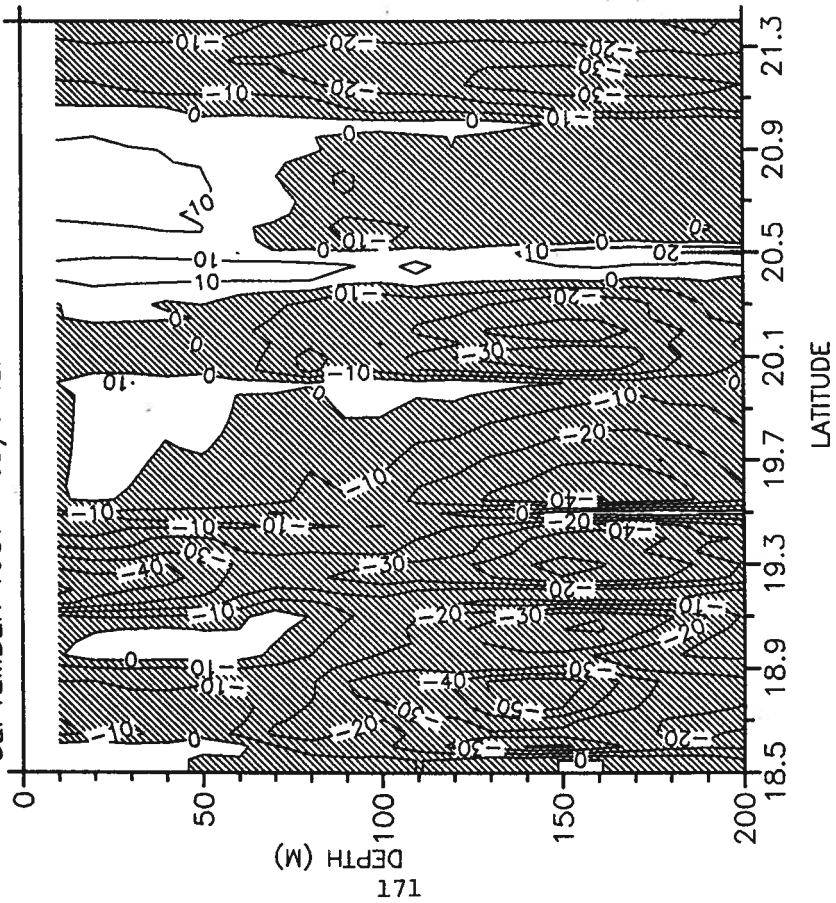

V-VELOCITY SECTION 6 (LORAN)

SEPTEMBER 1987 JD/TIME: 251.24 - 252.69

